

*we show you movement*

**BG**  
SERIES

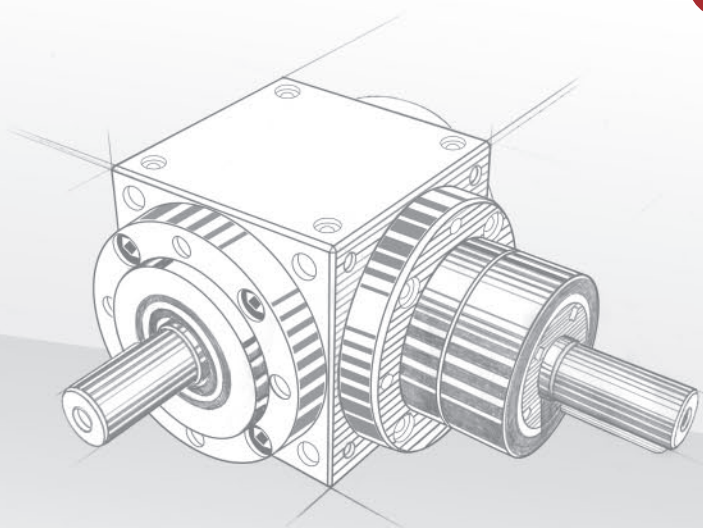

**rinvii angolari / invertitori**  
**spiral bevel gearboxes**  
**renvoi d'angle**  
**kegelradgetriebe**



**P.C.M. S.R.L.**



## Profilo azienda

 L'azienda PCM ha sede in Monselice (PD), in stabilimenti di 6000 mq, su una area complessiva di oltre 30000 mq. E' collocata in una Zona Industriale felicemente collegata in modo viario, autostradale e ferroviario, ed è facilmente raggiungibile da qualsiasi località del Nord Italia.

Lo stabilimento di recente costruzione è dotato di macchinari moderni che coprono ogni fase operativa di lavorazione del ciclo produttivo, affidato a personale di lunga e provata esperienza.

L'ultra decennale operatività dell'Azienda, ha portato la PCM a raggiungere livelli dimensionali, qualitativi e produttivi di primaria importanza ponendola a garanzia di un elevato grado di risposte qualificate, dinamiche e puntuali a soddisfazione delle esigenze della clientela.

Il raggiungimento di livelli qualificativi in certificazione, garantiscono i prodotti sotto tutti gli aspetti per accuratezza esecutiva, rendimenti ed attualità produttiva. La produzione dell'azienda si esplica in un'ampia gamma di gruppi adatti a molte esigenze nel campo della trasmissione di potenza, quali:

- rinvi angolari e invertitori
- fasatori epicicloidali
- riduttori ad assi paralleli
- riduttori ad assi ortogonali
- martinetti meccanici
- cambi
- gruppi di sollevamento
- ingranaggi conici (metodo Gleason)
- ingranaggi cilindrici
- ingranaggi su disegno del cliente
- gruppi meccanici assemblati

## Company profile

 PCM Company has its head offices in Monselice (PD), on a total surface of more than 30000 sqm, 6000 of which are covered. It is situated in an Industrial Area which is easily connected by the most important railway and motorway networks and it could be reached by all places of North of Italy.

The newly built establishment has been equipped with the most updated plants being able to cover any working phase of the manufacturing cycle managed by highly specialized and skilled personnel.

The Company has been working for over ten years enabling it to reach high qualitative, manufacturing and dimensional levels becoming a leading Company in this sector replying with qualified, dynamic and punctual answers to any exigencies of the customers.

All our products are covered by qualified certifications for granting them accuracy in the manufacturing, high yields and updated productions. Our wide range of products comply with any type of exigency in the power transmission field, as follows:

- spiral bevel-gears and reversing gears
- planetary speed modulation gears
- parallel-axes reducers
- orthogonal-axes reducers
- mechanical screw jacks
- transmissions
- lifting units
- cone-shaped gears (Gleason method)
- cylindrical-shaped gears
- customised gears
- assembled mechanical units

## L'entreprise

 L'entreprise PCM dont le siège social est à Monselice (PD), s'étend sur une surface totale de 30000 mc ayant des établissements de 6000 mc. Elle est implantée dans une Zone Industrielle très bien reliée par un réseau routier, autoroutier et ferroviaire et donc on peut l'atteindre aisément de n'importe quelle localité du Nord d'Italie.

Le nouvel établissement est équipé des appareils les plus modernes conçus pour chaque phase opérationnelle du cycle de production et géré par du personnel spécialisé ayant une longue expérience.

Grâce à son expérience opérationnelle ultra-décennale, PCM a atteint des importants niveaux dimensionnels, qualitatifs et productifs en assurant un très haut degré de qualité avec réponses qualifiées, dynamiques et ponctuelles capables de satisfaire les exigences des clients.

Les niveaux qualitatifs ont permis d'obtenir l'attribution de la certification qui assure les produits sous tous ses aspects pour soin d'exécution, efficacité et actualité de production. La production de l'entreprise inclus une vaste gamme de groupes conçus pour plusieurs exigences dans le domaine de la transmission de puissance, c'est-à-dire:

- renvois d'angle et inverseurs
- phaseurs mécaniques épicycloïdaux
- réducteurs à axes parallèles
- réducteurs à axes orthogonaux
- vérins mécaniques
- boîte de vitesses
- dispositifs de levage
- engrenages coniques (méthode Gleason)
- engrenages cylindriques
- engrenages sur dessin du client
- assemblages mécaniques

## Unternehmensprofil

 Die Firma PCM hat ihren Sitz in Monselice (PD), in Werken von 6000 qm, auf einem Gesamtgebiet von über 30000 qm. Sie befindet sich in einem Industriegebiet, das mit Straßen, Autobahnen und Eisenbahnen gut verbunden ist, und ist von jeder Ortschaft im Nord Italien leicht erreichbar.

Das neulich gebaute Werk ist mit modernen Maschinen ausgestattet, welche jede Bearbeitungsphase des Produktionsablaufs abdecken, wofür Personal langer und bewährter Erfahrung zuständig ist.

Das Vorhandensein der Firma im Sektor seit mehr als zehn Jahren erlaubte PCM, dimensionale, Qualitäts- und Fertigungsniveaus von wesentlicher Bedeutung zu erreichen und qualifizierte, dynamische und pünktliche Antworten zur Befriedigung der Anforderungen der Kundschaft zu garantieren. Dank der Erlangung von qualifizierenden Niveaus in der Zertifizierung werden die Produkte in jeder Hinsicht garantiert, was Ausführungsgenauigkeit, Leistungsfähigkeit und aktuelle Fertigungsverfahren betrifft.

Die Herstellung der Firma entwickelt sich in eine große Auswahl an Einheiten, die für viele Anforderungen im Sektor der Leistungsübertragung geeignet sind, wie:

- Kegelradgetriebe und Wendegetriebe
- Umlauf- Drehzahl-Überlagerungsgetriebe
- Untersetzungsgetriebe mit parallelen Achsen
- Untersetzungsgetriebe mit orthogonalen Achsen
- Mechanische Spindelhubelemente
- Wechselgetriebe
- Hebeeinheiten
- Kegelräder (Gleason-Metode)
- Stirnräder
- Räder nach Zeichnung des Kunden
- Zusammengebaute mechanische Einheiten



## 1. CARATTERISTICHE COSTRUTTIVE

 I rinvii ad angolo della serie BG rappresentano quanto di più avanzato la moderna tecnologia offre nel settore.

Si distinguono per il favorevole rapporto Potenza-Ingombro e per la possibilità di funzionamento silenzioso e regolare anche a velocità elevate.

Presentano le seguenti caratteristiche costruttive principali:

- Scatole cubiche costituite da ghisa meccanica, lavorate su tutte le facce e con fori filettati tali da consentire il fissaggio in ogni posizione (profondità del filetto pari a 2 volte il diametro).
- Coperchi e Mozzi con doppio centraggio (in tolleranza h7) e con una serie di fori filettati (tranne la grandezza 75) per eventuali fissaggi coassiali.
- Ingranaggi conici elicoidali costruiti in acciaio legato, dentati con sistema spiroidale GLEASON, cementati, temprati e lappati in coppia sulla generatrice ideale.
- Alberi costruiti in acciaio bonificato, rettificati in ogni parte
- Tolleranza alberi sporgenti j6
- Tolleranza fori alberi cavi H7 - H8
- Estremità cilindriche con foro filettato m testa secondo UNI 3221
- Linguette secondo UNI 6604

L'accurata costruzione degli ingranaggi consente, a richiesta ed a seconda delle velocità di funzionamento, il montaggio con minimi giochi angolari tra i denti.

La buona esecuzione dei componenti, nonché l'accurato montaggio, consentono di ottenere un rendimento totale pari al 94-97%.

Il disegno modulare permette di equipaggiare il rinvio con alberi supplementari, fino ad un massimo di 6 (tranne che il rapporto 1/1).



## 2. LUBRIFICAZIONE

I rinvii vengono forniti già lubrificati con grasso a vita, per utilizzo con velocità di ingresso **non superiore a 1000 giri/min.**

In tutti gli altri casi (da segnalare in caso di ordinazione) è da prevedere una lubrificazione ad olio.

Il rinvio, in quest'ultimo caso, viene fornito di tappo di carico e sfiato, indicatore di livello e tappo di scarico, mentre il lubrificante è a cura del cliente.

Per le posizioni si rimanda agli schemi riportati per ogni forma costruttiva, dove viene usata la seguente simbologia:

	Tappo di carico e sfiato
	Indicatore di livello
	Tappo di scarico

I rinvii angolari motorizzati, gli invertitori ed i rinvii con disinnesto sono normalmente lubrificati ad olio.

Per impieghi particolari (elevate velocità di funzionamento o servizio gravoso) nei quali si supera il limite termico più avanti specificato, è possibile l'applicazione di sistemi di refrigerazione diversi per i quali è necessario interpellare il ns. ufficio tecnico.

## 1. CONSTRUCTION FEATURES

 Spirai bevel gearboxes BG incorporate the most modern advances in bevel gearbox design and construction.

These gearboxes offer an extensive range of ratios together with an excellent power to size relationship as well as low noise levels even at high speed operation.

- The gearbox, which is made in cast iron, is of cuboid design with all external faces machined and with threaded fixing positions on each face (usable depth of threaded hole = twice the diameter).
- Input and output covers and housing are supplied with two location spigot diameters (h7) together with threaded fixing holes (except size BG75) for possible co-axial fixing.
- The alloy steel spirai bevel gears are cut in the GLEASON system, case hardened, tempered and lapped to the exact mounting position.
- Input and output shafts are manufactured in hardened and tempered steel with all surfaces ground.
- Input and output shaft tolerance j6.
- Hollow shaft tolerance H7 - H8
- All shafts supplied with threaded end to UNI 3221 - DIN 332.
- Keyways to UNI 6604 - DIN 6885.

On request and dependent upon speed type BG spirai bevel gearboxes may be assembled with minimum backlash.

Due to the quality of the gears and machining tolerances, an overall efficiency of between 94 and 97% can be expected.

The modular construction of BG spirai bevel gearboxes permits up to six input/output shafts (except ratio 1:1).



## 2. LUBRICATION

BG spirai bevel gearboxes are supplied grease lubricated for **input speeds up to 1000 rpm**, for higher speeds or on request oil lubrication is available.

In this case the gearboxes will be supplied with a filler /breather plug, level indicator and drain plug.

The spiral bevel gearbox, in the latter case, is supplied with filler and breather plug, level gauge and drain plug, while lubricant falls under customer's responsibility.

Filler, level and drain positions are indicated as follows:

	Filler / breather plug
	Level indicator plug
	Drain plug

Motorised spirai bevel gearboxes, reversing bevel gearboxes and disengaging bevel gearboxes are usually oil lubricated.

For high speed and/or high ambient temperature conditions it may be necessary to apply external cooling.

Please consult our technical department.



## 1. CARACTÉRISTIQUES DE CONSTRUCTION

 Les renvois d'angle BG représentent ce que le secteur offre de plus avancé en termes technologiques.

Ils se différencient pour la relation favorable Puissance-Encombrement et pour un fonctionnement silencieux et régulier même à haute vitesse.

Ils présentent les caractéristiques de construction suivantes :

- Boîtes cubiques, réalisées en fonte mécanique, façonnés sur tous les côtés avec des trous taraudés qui permettent la fixation dans toute position (profondeur du filet est 2 fois le diamètre).
- Couverts et moyeux avec un centrage double (à la tolérance h7) et avec une série de trous taraudés (excepté pour la valeur 75) pour les fixations coaxiales éventuelles.
- Les engrenages coniques hélicoïdaux sont en acier allié, à denture spirale GLEASON, cémentés, trempés et soumis à polissage sur une génératrice.
- Arbres en acier trempé, entièrement rectifiés
- Tolérance arbres étendus J6
- Tolérance trous arbres creux H7 - H8
- Bords des cylindres avec trou taraudé en tête selon UNI 3221
- Clavette selon UNI 6604

La construction soignée des engrenages permet, sur demande et selon la vitesse de fonctionnement, le montage avec des jeux angulaires minimum entre les dents.

La bonne exécution des composants et le montage soigné permettent d'obtenir un rendement total égal à 94-97 %.



Le dessin modulaire permet de doter le renvoi d'arbres supplémentaires, jusqu'à un maximum de 6 (excepté pour le rapport 1/1).

## 2. LUBRIFICATION

Les renvois sont fournis déjà lubrifiés avec lubrification permanente pour en permettre l'utilisation avec vitesse d'entrée **non supérieure à 1.000 tr/mn**. Dans tous les autres cas (à signaler en phase de commande) il est nécessaire une lubrification à l'huile.

En ce dernier cas, le renvoi est doté de bouchon de remplissage/évent, indicateur de niveau et bouchon de vidange, alors que le lubrifiant est par les soins du client.

Pour les positions faire référence aux schémas pour toute forme de construction où les symboles suivants sont utilisés:

	Bouchon de remplissage/évent
	Indicateur de niveau
	Bouchon de vidange

Les renvois d'angle motorisés, les variateurs et les renvois avec débrayage sont normalement lubrifiés à l'huile.

Pour des emplois particuliers (vitesse de fonctionnement ou prestations élevées), soit ceux qui dépassent le niveau thermique ci-dessous décrit, il est possible d'appliquer des systèmes de refroidissement différents pour lesquels il est nécessaire s'adresser à notre bureau technique.

## 1. HAUPTKONSTRUKTIONSMERKMALE

 Diese spiralverzahnten Kegelradgetriebe sind das Fortschrittlichste, was die moderne Technik auf diesem Sektor zu bieten hat.

Sie zeichnen sich durch das günstige Verhältnis Leistung/Platzbedarf, auch bei hohen Drehzahlen durch einen geäusscherten und gleichmäßigen Lauf aus.

- Kubische Gehäuse aus Grauguß sind allseitig bearbeitet und mit Gewindebohrungen versehen, so daß eine Befestigung in jeder Position möglich ist. (Tiefe der Gewindebohrung ist gleich zweifacher Bohrungsdurchmesser).
- Deckel und Naben sind mit Doppelzentrierung (Toleranz h7) und Gewindebohrungen versehen (Ausnahme: Größe 75) für koaxiale Fixierungen.
- Spiralverzahnte Kegelräder sind aus hochwertigem Stahl gefertigt, mit GLEASON Verzahnung, einsatzgehärtet, getempert und geläpft.
- Wellen aus einsatzgehärtetem, getempertem Stahl, geschliffen.
- Toleranz der wellenenden j6
- Toleranz der Hohlwellenbohrungen H7, H8
- Wellen-Enden mit Gewindebohrung gemäß UNI 3221
- Paßfedern gemäß UNI 6604, DIN 6885

Die präzise Herstellung der Kegelräder ermöglicht auf Wunsch und abhängig von der Betriebsgeschwindigkeit, kleinstes Winkelspiel zwischen den Zähnen.

Die Qualität der Komponenten, sowie die sorgfältige Montage, ermöglichen einen Gesamtwirkungsgrad von 94 - 97 %.

Die Modulbauweise ermöglicht es, die Kegelradgetriebe mit bis zu 6 Wellen zu bestücken (Ausnahme: Übersetzung 1:1).



## 2. SCHMIERUNG

Die Kegelradgetriebe werden serienmäßig mit Fettschmierung **für eine Eingangsdrehzahl bis 1000 min<sup>-1</sup> geliefert**.

In allen anderen Fällen (bei der Bestellung angegeben) ist eine Ölschmierung vorzusehen.

Das Vorgelege wird in diesem Fall mit einem Füll- und Entlüftungsstutzen, einer Standanzeige und einem Ablassstutzen geliefert, wogegen für das Schmiermittel der Kunde zu sorgen hat.

Folgende Symbole werden verwendet:

	Einfüll- und Entlüftungsstutzen
	Ölstandanzeige
	Ablassschraube

Durch einen Motor angetriebene Kegelradgetriebe, Wendegetriebe und Kegelradgetriebe mit Entkupplung sind normalerweise mit Ölschmierung zu versehen.

Für spezielle Anwendungen, bei denen z.B. die thermische Grenze überschritten wird, besteht die Möglichkeit andere Kühlsysteme anzuwenden, vorher unbedingt Rücksprache mit unserer technischen Abteilung nehmen.

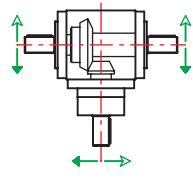
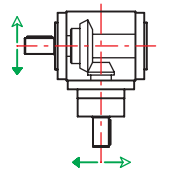
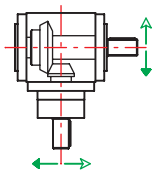
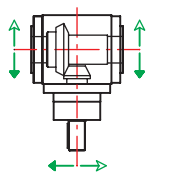
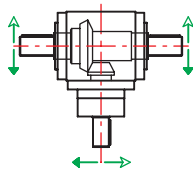
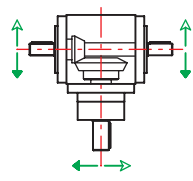
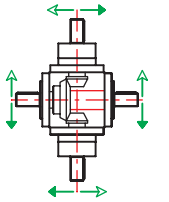
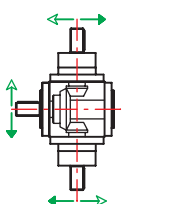

Schema / Assembly Schéma / Die Montage	Forma / Type Forme / Form	Note / Note Remarques / Die Eigenschaft	Rapporti / Ratio Rapports / Übersetzung	Pag.
	<b>A</b>	Albero lento bisporgente <i>Slow shaft double projection</i> Arbre lent bilatéral <i>Doppelseitige langsam laufende Welle</i>	1:1, 1.5:1, 2:1, 3:1, 4:1, 5:1	20
	<b>AD</b>	Albero lento singolo <i>Slow shaft single projection</i> Arbre lent unilatéral <i>Einseitige langsam laufende Welle</i>	1:1, 1.5:1, 2:1, 3:1, 4:1, 5:1	22
	<b>AS</b>	Albero lento singolo <i>Slow shaft single projection</i> Arbre lent unilatéral <i>Einseitige langsam laufende Welle</i>	1:1, 1.5:1, 2:1, 3:1, 4:1, 5:1	24
	<b>AH</b> <b>AHC</b> <b>AHS</b>	Albero lento cavo - con chiavetta - con calettatore - scanalato <i>Hollow slow shaft</i> Arbre lent creux - avec clavette - avec frette - cannelé <i>Langsam laufende Hohlwelle</i>	1:1, 1.5:1, 2:1, 3:1, 4:1, 5:1	26 28 30
	<b>AP</b>	Albero lento rinforzato <i>Reinforced slow shaft double projection</i> Arbre lent renforcé <i>Doppelseitige, verstärkte langsam laufende Welle</i>	1.5:1 2:1	32
	<b>AX</b>	Moltiplicatore <i>Speed increase</i> Multiplificateur <i>Doppelseitige, schnell laufende Welle</i>	1:1, 1.5:1, 2:1, 3:1, 4:1, 5:1	34
	<b>B</b>	Albero lento bisporgente - 2 alberi veloci controrotanti <i>Slow shaft double projection -</i> <i>2 fast shafts counter rotating</i> Arbre lent bilatéral - Deux arbres rapides contrarotatifs <i>Doppelseitige, langsam laufende Welle -</i> <i>2. Welle schnell laufend</i>	1:1, 1.5:1, 2:1, 3:1, 4:1, 5:1	36
	<b>BD</b>	Albero lento bisporgente - 2 alberi veloci controrotanti <i>Slow shaft single projection -</i> <i>2 fast shafts counter rotating</i> Arbre lent bilatéral - Deux arbres rapides contrarotatifs <i>Einseitige, langsam laufende Welle</i> <i>zwei schnell laufende Wellen</i>	1:1, 1.5:1, 2:1, 3:1, 4:1, 5:1	38

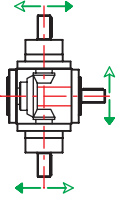
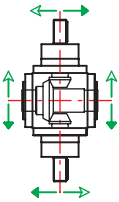
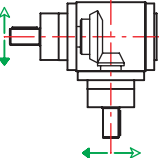
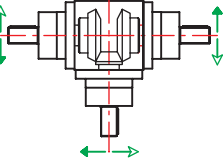
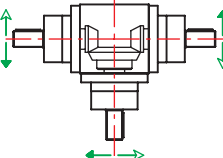
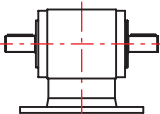
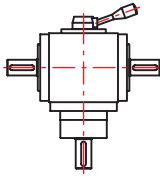
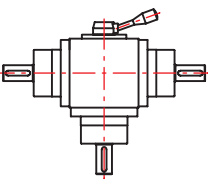

Schema / Assembly Schéma / Die Montage	Forma / Type Forme / Form	Note / Note Remarques / Die Eigenschaft	Rapporti / Ratio Rapports / Übersetzung	Pag.
	<b>BS</b>	Albero lento bisporgente 2 alberi veloci controrotanti <i>Slow shaft single projection</i> 2 fast shafts counter rotating Arbre lent bilatéral - 2 arbres rapides contrarotatifs <i>Einseitige, langsam laufende Welle</i> zwei schnell laufende Wellen	1:1, 1.5:1, 2:1, 3:1, 4:1, 5:1	40
	<b>BH</b> <b>BHC</b> <b>BHS</b>	Albero lento cavo - con chiavetta - con calettatore - scanalato 2 alberi veloci controrotanti <i>Hollow slow shaft</i> 2 fast shafts counter rotating Arbre lent creux - avec clavette - avec frette - cannelé - 2 arbres rapides contrarotatifs <i>Langsam laufende Hohlwelle</i> zwei schnell laufende Wellen	1:1, 1.5:1, 2:1, 3:1, 4:1, 5:1	42 44 46
	<b>C</b>	Moltiplicatore Riduttore <i>Slow shaft single projection</i> with bearing housing Multiplicateur réducteur <i>Einseitige, verstärkte langsam</i> laufende Welle	1:1, 1.5:1, 2:1, 3:1, 4:1, 5:1	48
	<b>DR</b>	Riduttore alberi lenti controrotanti <i>Counter rotating slow shaft</i> Réducteur arbres lents contrarotatifs <i>Doppelseitige, gegenläufige,</i> langsam laufende Welle	1:1, 1.5:1, 2:1, 3:1, 4:1, 5:1	50
	<b>DX</b>	Moltiplicatore alberi lenti controrotanti <i>Counter rotating speed increase</i> Multiplicateur arbres lents contrarotatifs <i>Doppelseitige, gegenläufige, schnell</i> laufende welle	1:1, 1.5:1, 2:1, 3:1, 4:1, 5:1	52
	<b>M..</b>	Predisposto flangiatura motore PAM <i>IEC Molar flange adapter</i> Prévu pour bridage moteur PAM <i>Getriebe mit IEC</i> Motorflanschadapter	1:1, 1.5:1, 2:1, 3:1, 4:1, 5:1	54
Rinvii multialbero / <i>Spiral bevel gearboxes multiple shafts</i> Renvois multi-arbres / <i>Kegelradgetriebe mit Mehrfachwellen</i>				56
	<b>IO</b> <b>DO</b>	Invertitore disgiuntore ortogonale <i>90° reversing gear type IO</i> and disengaging gear type DO Variateur disjoncteur orthogonal <i>90° Wendegetriebe, Schaltgetriebe,</i> auskuppelbar	1:1, 2:1, 1:3	60 62
	<b>IC</b>	Invertitore coassiale <i>Co-axial reversing gear</i> Variateur coaxial <i>Wendegetriebe, koaxial</i>	1:1	64

#### 4. PRESTAZIONI

-  I valori riportati in tabella sono validi per le seguenti condizioni:
- durata di funzionamento: 20.000 ore
  - macchina motrice: motore elettrico
  - carico applicato: uniforme
  - senso di rotazione: monodirezionale
  - ore di funzionamento: 8 ore al giorno
  - partenze orarie: 1 avviamento/ora
  - condizioni ambientali: temperatura 20°C - altitudine < 1000 m s.l.m.

#### 4. SELECTION

-  The selection assumes the following conditions, for other conditions refer to page 5:
- life rating: 20.000 hours
  - prime mover: electric motor
  - duty factor: uniform load
  - rotation: right or left-hand
  - service time: 8 hours a day
  - duty factor: 1 start/hour
  - ambiental conditions: temperature 20° altitude < 1000 m.o.s.

#### 4. PERFORMANCES

-  Les valeurs indiquées au tableau ci-dessous sont valables pour les conditions suivantes:
- durée de fonctionnement: 20 000 heures
  - élément moteur: moteur électrique
  - charge appliquée: uniforme
  - sens de rotation: monodirectionnel
  - heures de fonctionnement: 8 heures par jour
  - démarrages/heure: 1 démarrage/heure
  - conditions environnementales: température 20 °C – hauteur < 1000 m s.n.m

#### 4. LEISTUNGSANGABEN

##### AUSWAHL

-  Die in der Tabelle angegebenen Werte gelten unter den folgenden Bedingungen:
- Betriebszeit: 20000 Stunden
  - Antrieb: Elektromotor
  - Einschaltdauer: 100%
  - Drehrichtung: links, rechts
  - Betriebsart: 8 Stunden / Tag
  - Einschalthäufigkeit: 1 Anlaufen/ Stunde
  - Umgebungsbedingungen: Temperatur 20°C - Höhe < 1000 m ü.d.M.

4

TAGLIA UNIT SIZE TAILLE BAUTRÖBE	Giri/min ingresso input rpm Tr/mn entrée Eingang- Drehzahl min <sup>-1</sup>	Rapporto / Ratio Rapport / Übersetzung 1:1		Rapporto / Ratio Rapport / Übersetzung 1,5:1		Rapporto / Ratio Rapport / Übersetzung 2:1		Rapporto / Ratio Rapport / Übersetzung 3:1		Rapporto / Ratio Rapport / Übersetzung 4:1		Rapporto / Ratio Rapport / Übersetzung 5:1	
		Potenza ingresso Power input Puissance d'entrée Eingangs- leistung kW	Coppia uscita Torque output Couple de sortie Nm Ausgangs- drehmoment Nm	Potenza ingresso Power input Puissance d'entrée Eingangs- leistung kW	Coppia uscita Torque output Couple de sortie Nm Ausgangs- drehmoment Nm	Potenza ingresso Power input Puissance d'entrée Eingangs- leistung kW	Coppia uscita Torque output Couple de sortie Nm Ausgangs- drehmoment Nm	Potenza ingresso Power input Puissance d'entrée Eingangs- leistung kW	Coppia uscita Torque output Couple de sortie Nm Ausgangs- drehmoment Nm	Potenza ingresso Power input Puissance d'entrée Eingangs- leistung kW	Coppia uscita Torque output Couple de sortie Nm Ausgangs- drehmoment Nm	Potenza ingresso Power input Puissance d'entrée Eingangs- leistung kW	Coppia uscita Torque output Couple de sortie Nm Ausgangs- drehmoment Nm
BG12	2800	4.00	13.1	--	--	2.09	13.7	0.77	7.5	--	--	--	--
	2000	2.99	13.8	--	--	1.55	14.1	0.60	8.1	--	--	--	--
	1500	2.44	14.9	--	--	1.22	14.9	0.49	8.9	--	--	--	--
	1000	1.76	16.2	--	--	0.88	16.2	0.35	9.7	--	--	--	--
	800	1.52	17.4	--	--	0.77	17.4	0.30	10.5	--	--	--	--
	600	1.22	18.7	--	--	0.61	18.7	0.25	11.1	--	--	--	--
	400	0.87	20.0	--	--	0.44	20.0	0.17	11.5	--	--	--	--
	100	0.23	21.8	--	--	0.12	21.7	0.04	11.2	--	--	--	--
	50	0.13	23.6	--	--	0.07	23.6	0.03	12.7	--	--	--	--
10	0.026	24.9	--	--	0.01	24.9	0.01	13.1	--	--	--	--	
BG19	2800	21.15	69.2	9.57	46.9	8.46	55.3	3.12	30.6	2.69	35.2	1.72	28
	2000	15.52	71.1	6.99	48.1	6.15	56.4	2.28	31.2	1.5	27.5	1.25	28.4
	1500	11.92	72.9	5.36	49.0	4.68	57.2	1.74	31.8	1.13	27.6	0.94	28.7
	1000	8.13	74.6	3.65	50.1	3.20	58.6	1.18	32.3	0.77	28.3	0.64	29.2
	800	6.59	75.5	2.95	50.7	2.59	59.4	0.95	32.6	0.62	28.5	0.51	29.3
	600	5.01	76.4	2.25	51.4	1.96	59.9	0.72	33.0	0.47	28.8	0.39	29.6
	400	3.41	78.0	1.51	52.0	1.33	60.7	0.48	33.5	0.32	29	0.26	29.7
	100	0.90	81.7	0.39	53.9	0.35	63.4	0.13	34.3	0.08	29.7	0.07	30.4
	50	0.46	82.8	0.20	54.6	0.17	64.0	0.07	34.5	0.04	29.9	0.04	30.6
10	0.09	83.9	0.04	55.2	0.04	64.6	0.01	34.8	0.01	30.2	0.01	30.9	
BG24	2800	23.24	76.1	15.82	77.7	10.60	69.4	4.58	44.9	5.07	66.4	3.47	56.8
	2000	17.39	79.6	11.54	79.4	7.79	71.3	3.35	46.0	3.69	67.6	2.61	59.9
	1500	13.48	82.4	8.83	80.8	5.92	72.4	2.55	46.8	2.81	68.6	1.99	60.8
	1000	9.35	85.8	6.05	83.0	4.02	73.5	1.73	47.5	1.91	69.9	1.35	61.7
	800	7.62	87.3	4.88	83.8	3.25	74.3	1.40	48.3	1.53	70.3	1.09	62.4
	600	5.86	89.5	3.72	85.4	2.46	75.1	1.07	48.6	1.17	71.1	0.85	64.2
	400	4.00	91.7	2.52	86.7	1.66	76.1	0.72	49.4	0.78	71.8	0.57	64.8
	100	1.07	97.8	0.65	89.8	0.42	76.5	0.18	50.5	0.20	72.9	0.14	66.8
	50	0.55	100.1	0.33	91.0	0.21	76.8	0.09	50.7	0.10	74.1	0.08	67.3
10	0.12	103.3	0.07	92.4	0.04	77.3	0.01	50.9	0.03	74.8	0.01	68.6	





TAGLIA UNIT SIZE TAILLE BAUTRÖBE	Giri/min ingresso input rpm Tr/mn entrée Eingang- Drehzahl min <sup>-1</sup>	Rapporto / Ratio Rapport / Übersetzung 1:1		Rapporto / Ratio Rapport / Übersetzung 1,5:1		Rapporto / Ratio Rapport / Übersetzung 2:1		Rapporto / Ratio Rapport / Übersetzung 3:1		Rapporto / Ratio Rapport / Übersetzung 4:1		Rapporto / Ratio Rapport / Übersetzung 5:1			
		Potenza ingresso Power input Puissance d'entrée Eingangs- leistung kW	Coppia uscita Torque output Couple de sortie Nm Ausgangs- drehmoment Nm	Potenza ingresso Power input Puissance d'entrée Eingangs- leistung kW	Coppia uscita Torque output Couple de sortie Nm Ausgangs- drehmoment Nm	Potenza ingresso Power input Puissance d'entrée Eingangs- leistung kW	Coppia uscita Torque output Couple de sortie Nm Ausgangs- drehmoment Nm	Potenza ingresso Power input Puissance d'entrée Eingangs- leistung kW	Coppia uscita Torque output Couple de sortie Nm Ausgangs- drehmoment Nm	Potenza ingresso Power input Puissance d'entrée Eingangs- leistung kW	Coppia uscita Torque output Couple de sortie Nm Ausgangs- drehmoment Nm	Potenza ingresso Power input Puissance d'entrée Eingangs- leistung kW	Coppia uscita Torque output Couple de sortie Nm Ausgangs- drehmoment Nm	Potenza ingresso Power input Puissance d'entrée Eingangs- leistung kW	Coppia uscita Torque output Couple de sortie Nm Ausgangs- drehmoment Nm
		BG32	2800	53.04	173.4	30.55	149.7	20.15	132.3	9.53	93.6	7.05	92.3	4.58	74.8
2000	39.52		180.9	22.88	157.3	14.95	137.2	7.49	102.9	5.38	98.5	3.43	78.6		
1500	30.68		187.2	17.81	162.8	11.44	139.7	5.72	104.7	4.08	99.8	2.61	79.8		
1000	21.19		194.7	12.22	168.4	7.80	142.2	3.87	106.7	2.76	101.1	1.77	81.1		
800	17.29		198.3	10.14	174.0	6.37	144.8	3.16	108.5	2.24	102.3	1.44	82.4		
600	13.26		203.4	7.80	177.8	4.81	147.2	2.41	110.5	1.69	103.6	1.11	84.2		
400	9.10		208.3	5.33	183.4	3.25	149.7	1.64	112.3	1.14	104.7	0.74	85.5		
100	2.47		222.1	1.30	187.2	0.78	154.7	0.42	116.0	0.30	109.8	0.20	87.3		
50	1.17		227.1	0.65	190.9	0.39	159.7	0.21	117.9	0.16	112.3	0.09	88.6		
10	0.26	234.6	0.13	194.7	0.13	162.2	0.04	119.8	0.03	114.7	0.03	89.8			
BG38	2800	113.36	371.2	75.01	355.5	38.87	254.8	19.6	192.4	15.99	209.3	12.87	210.6		
	2000	83.33	382.2	53.3	366.6	28.60	261.3	14.3	197.6	11.70	213.2	9.36	215.1		
	1500	64.22	392.6	40.82	374.4	21.97	267.8	10.9	200.2	8.84	217.1	7.15	219		
	1000	43.94	403.0	27.82	381.9	15.08	275.6	7.49	205.4	5.98	221.0	4.81	222.3		
	800	35.88	411.4	22.62	390	12.22	279.15	6.06	208	4.81	222.3	3.90	224.9		
	600	27.43	419.9	17.29	396.5	9.23	283.4	4.62	211.2	3.64	225.5	2.99	227.5		
	400	18.85	430.3	11.70	404.3	6.24	288.6	3.12	214.5	2.47	229.4	1.95	229.4		
	100	4.94	453.7	3.12	423.1	1.69	300.3	0.81	221.6	0.65	236.6	0.52	236.6		
	50	2.47	462.1	1.56	432.1	0.78	304.2	0.40	223.6	0.33	238.5	0.26	239.2		
10	0.52	477.1	0.26	442	0.17	310.7	0.08	227.5	0.07	241.8	0.05	241.8			
BG42	2800	133.3	437	81.2	399	45.7	299	23.1	228	17.8	234	12.8	211		
	2000	98	450	59.8	412	33.5	308	16.9	231	13	238	9.3	216		
	1500	75.5	461	45.8	421	25.7	316	12.8	335	9.8	243	7.1	219		
	1000	51.7	474	31.5	434	17.6	324	8.8	242	6.7	248	4.8	222		
	800	42.2	484	25.6	441	14.3	329	7.1	244	5.4	251	3.9	225		
	600	32.3	494	19.5	447	10.9	334	5.4	248	4.1	254	2.9	228		
	400	22.1	507	13.3	459	7.4	339	3.6	252	2.8	257	1.9	230		
	100	5.85	534	3.5	481	1.9	354	0.9	261	0.7	265	0.5	237		
	50	2.99	546	1.8	489	0.9	361	0.48	264	0.33	268	0.26	239		
10	0.65	562	0.4	498	0.2	365	0.09	268	0.07	272	0.05	242			
BG55	1500	162.5	992	115.3	1057	57.7	706	26	481	25.3	621	19.5	595		
	1000	111.8	1023	78.9	1086	39.7	729	18	497	17.2	636	13.2	607		
	800	91	1040	64.2	1105	32.2	738	14.6	502	14	644	10.6	614		
	600	68.9	1053	49	1123	24.4	749	11	508	10.6	651	8.1	621		
	400	47.5	1092	34	1161	16.7	768	7.5	517	7.2	662	5.4	629		
	100	12.6	1161	8.9	1235	4.4	803	1.95	541	1.8	688	1.4	654		
	50	6.5	1186	4.5	1264	2.2	822	1.04	547	0.9	694	0.78	660		
	10	1.3	1223	0.9	1300	0.46	836	0.21	556	0.20	706	0.13	670		
BG75	1500	344	2109	191	1754	142	1723	96	1772	60	1466	42	1278		
	1000	240	2202	133	1817	98	1778	66	1823	42	1505	29	1309		
	800	196	2264	108	1847	79	1808	53	1850	34	1525	23	1323		
	600	151	2301	82	1888	60	1841	42	1881	25	1547	18	1342		
	400	104	2371	56	1937	42	1884	27	1918	17	1576	12	1364		
	100	27	2552	14	2061	10	1992	7.8	2015	3.9	1645	2.6	1418		
	50	14	2612	8	2102	5	2028	3.9	2046	2.6	1667	1.3	1435		
	10	3	2700	1.5	2161	1.1	2076	0.7	2088	0.5	1698	0.26	1457		

Nel caso il senso di rotazione sia BIDIREZIONALE le prestazioni vanno ridotte del 30%.

If the bevel gear rotate left-hand and right-hand, reduce the performances of 30%.

Au cas où le sens de rotation est BIDIRECTIONNEL les prestations doivent être réduites de 30%.

Ist die Rotation in beide Richtungen, vermindert sich die obengenannten Leistungsangaben um 30%.





**Esempi di  
customizzazioni  
su richiesta cliente**



**Examples of  
customization  
on customer request**



**Exemples de  
personnalisation  
sur demande du client**



**Beispiele für  
Anpassung  
auf Kundenwunsch**

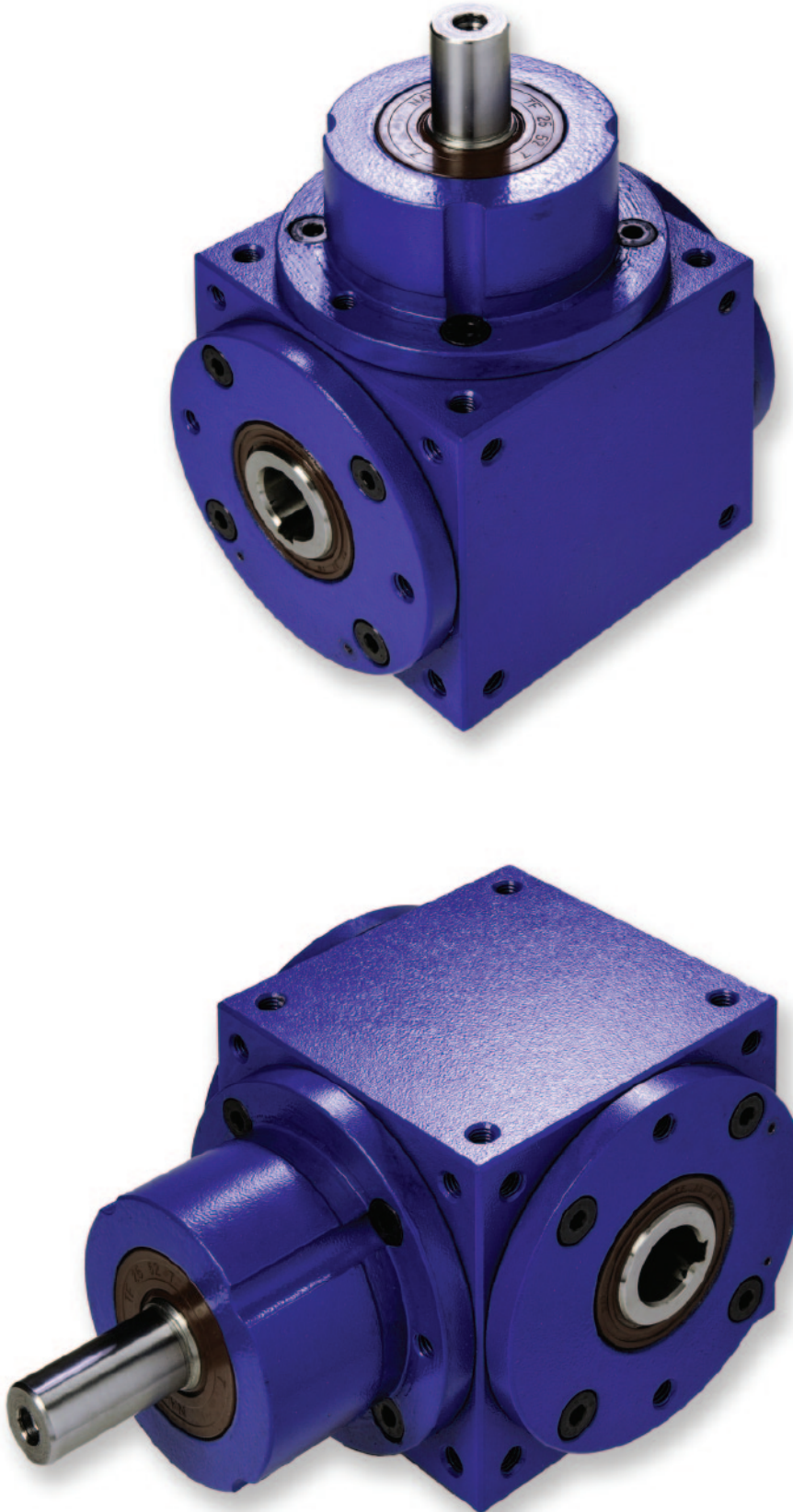

## 5. CRITERI DI SCELTA E DIMENSIONAMENTO

 Ove le condizioni di lavoro siano diverse da quelle introdotte per calcolare i valori di Potenza e Coppia resa riportati nella tabella precedente, occorre considerare i seguenti fattori correttivi che tengono conto delle reali condizioni di impiego e scegliere quindi la grandezza del rinvio più idonea. I fattori da utilizzare sono i seguenti:

## 5. SELECTION PROCEDURE

 When working conditions are different from those in the selection table, service factors must be considered. The service factors are as following:

## 5. CRITÈRES DE CHOIX ET DIMENSIONNEMENT

 Lorsque les conditions de travail sont différentes par rapport à celles présentées pour le calcul des valeurs Puissance et Couple rendus indiquées au tableau précédent, il faut tenir en compte les facteurs de correction suivants qui incluent les conditions réelles d'emploi et choisir donc la taille de renvoi la plus adaptée. Les facteurs à utiliser sont les suivants:

## 5. AUSWAHL- UND DIMENSIONIERUNGSKRITERIEN

 Unterscheiden sich die Betriebsbedingungen von den in der obenaufgeführten Tabelle angewandten Berechnungswerten für Leistung und Drehmoment, empfiehlt es sich folgende Korrekturfaktoren zu verwenden, um die Größe des am besten geeigneten Kegelradgetriebes auszuwählen:

H = Fattore di utilizzazione oraria / *Service time* / Facteur d'utilisation horaire / *Faktor Betriebsart*

Ore/giorno / <i>Hours/days</i> / Heures/jour / <i>Stunden pro Tag</i>	24	18	12	8	4	2	1
H	1.25	1.18	1.11	1	0.9	0.8	0.7

L = Fattore di durata / *Life rating* / Facteur de durée / *Faktor Betriebsdauer in Stunden*

Durata teorica / <i>Theoric time</i> / Durée théorique / <i>Theoretische Dauer</i>	60000	40000	20000	15000	10000	5000	3000
L	1.3	1.15	1	0.95	0.9	0.85	0.8

C = Fattore di carico (tipo e numero di avviamenti) / *Duty factor*  
Facteur de charge (type et nombre des démarrages) / *Einschalhäufigkeit*

	Numero di avviamenti orari / <i>No. of starts/hour</i> Nombre des démarrages / <i>heure</i> / <i>Startzyklen pro Stunde</i>					
	Saltuario <i>Irregular</i> Sporadique <i>Unregelmäßig</i>	1	5	20	60	120
Carico uniforme / <i>Uniform</i> / Charge uniforme / <i>Gleichmäßige Belastung</i>	1	1	1.4	1.8	2.2	2.7
Carico con urti moderati / <i>Moderate shock</i> Charge avec à coups modérés / <i>Leichte Stoßbelastung</i>	1	1.4	1.8	2.2	2.7	3.2
Carico con urti forti / <i>Heavy shock</i> Charge avec à coups violents / <i>Starke Stoßbelastung</i>	1.4	1.8	2.2	2.7	3.2	3.8

La coppia necessaria M andrà moltiplicata per i fattori sopra indicati per ottenere il valore della coppia MU da utilizzare per la scelta del rinvio.

The required torque (M) will be multiplied for the above mentioned factors to obtain the value of torque (MU) to use to select a spiral bevel gearboxes of the correct size.

Le couple nécessaire M sera multiplié par les facteurs ci-dessus pour obtenir la valeur du couple MU à utiliser pour le choix du renvoi.

Das benötigte Drehmoment M wird mit den obengenannten Faktoren multipliziert, um den Wert des Drehmoments MU für die Wahl des Kegelradgetriebes zu erhalten:

$$MU = M \times (H \times L \times C)$$



## 6. POTENZA TERMICA

 Per potenza termica PT si intende quella potenza che può essere applicata all'entrata del rinvio in servizio continuo, ad una temperatura massima ambientale di 20°C e tale da mantenere la temperatura massima del lubrificante al di sotto dei 90°C.

## 6. THERMAL RATING (PT)

 The thermal rating is that power that can be applied at the input of the bevel gearboxes, working continuously at an ambient temperature of 20°, such as to maintain the lubrication temperature under 100° C.

## 6. PUISSANCE THERMIQUE

 La puissance thermique PT représente la puissance qui peut être appliquée à l'entrée du renvoi en service continu à une température ambiante maximum de 20 °C afin de maintenir une température maximum du lubrifiant au-dessous de 90 °C.

## 6. THERMISCHE LEISTUNG

 Unter Thermischer Leistung (PT) versteht man die Leistung, die am Eingang des Kegelradgetriebes bei Dauerbetrieb und einer Umgebungstemperatur von 20°C angeschlossen werden kann, ohne die Temperatur (100°C) des Schmierstoffes zu überschreiten.

TAGLIA / UNIT SIZE TAILLE / BAUTRÖBE	BG12	BG19	BG24	BG32	BG38	BG42	BG55	BG75
PT (kW)	1.5	3	6	10	16	20	35	60
input RPM min <sup>-1</sup>	2800	2800	2800	2800	2000	2000	1500	1000

Per valutare la Potenza Termica Reale occorre tener conto dei seguenti fattori:

When conditions are different from these above it will be necessary to consider the following factors:

Pour évaluer la Puissance Thermique Réelle il faut considérer les facteurs suivants:

Für andere Bedingungen sind folgende Faktoren zu verwenden:

T = Fattore di temperatura ambientale / Ambient temperature factor  
Facteur température environnementale / Korrekturfaktor Umgebungstemperatur

Temperature °C / Temperature °C / Température °C / Temperatur °C	-10	0	10	20	30	40	50
T	1.3	1.25	1.15	1	0.9	0.8	0.7

ED = Fattore di utilizzo / Duty factor / Facteur d'utilisation / Korrekturfaktor Einschaltdauer

% utilizzo / % duty factor / % d'utilisation / %	100	80	60	40	20
ED	1	1.2	1.4	1.6	1.8

La Potenza Termica (PT) sopra riportata andrà moltiplicata per i fattori di cui sopra per ottenere la Potenza Termica Reale (PTR):

Thermal rating (PT) should be multiplied by the above factors to obtain the actual thermal rating (PTR):

La Puissance Thermique (PT) ci-dessus sera multipliée par les facteurs mentionnés plus haut pour obtenir la puissance Thermique Idéelle (PTR):

Die daraus folgende zulässige Eingangsleistung kann wie folgt berechnet werden:

$$PTR = PT \times (T \times ED)$$

Quando la Potenza continuativa assorbita dall'impianto in cui opera il rinvio supera il valore della Potenza Termica Reale (PTR), occorre asportare la quantità di calore in eccesso mediante sistemi di raffreddamento artificiali annessi al rinvio.

When the continuous absorbed rating in the bevel gearbox is over the actual thermal rating (PTR), excess heat must be removed by artificial cooling.

Lorsque la Puissance continue absorbée par l'installation dans laquelle le renvoi travaille dépasse la valeur de Puissance Thermique Réelle (PTR), il faut dissiper la quantité de chaleur en excès par des systèmes de refroidissement artificiels reliés au renvoi.

Wenn die effektiv aufgenommene Leistung höher als PTR sein sollte, so muß das Getriebe mit einer externen Kühlung versehen werden. (Bitte Rücksprache halten).



## 7. PESI

 I pesi in Kg si riferiscono al modello base forma A, rapporto 1/1.

## 7. WEIGHT

 Weights are referred to units type A, ratio 1:1.

## 7. POIDS

 Les poids en Kg se réfèrent au modèle de base forme A, rapport 1/1.

## 7. GEWICHTE

 Die e Gewichte beziehen sich auf das Basismodell FORM A, Übersetzung 1:1.

TAGLIA / UNIT SIZE TAILLE / BAUTRÖBE	BG12	BG19	BG24	BG32	BG38	BG42	BG55	BG75
Peso (kg) / Weight (kg) Poids (Kg) / Gewicht (kg)	2.5	6	12	22	37	57	87	255

## 8. QUANTITÀ DI LUBRIFICANTE

Le quantità in litri si riferiscono al modello base forma A, rapporto 1/1.

## B. LUBRICANTS (QUANTITIES)

Lubricants are referred to units type A, ratio 1:1.

## 8. QUANTITÉ DE LUBRIFIANT

Les quantités en litres se réfèrent au modèle de base forme A, rapport 1/1.

## 8. SCHMIERMITTEL

Die Mengen beziehen sich auf das Basismodell FORM A, Übersetzung 1:1.

TAGLIA / UNIT SIZE TAILLE / BAUTRÖBE	BG12	BG19	BG24	BG32	BG38	BG42	BG55	BG75
Grasso (l) / Graase (l) Graisse (l) / Gewicht (kg)	0.15	0.22	0.35	0.9	1.7	3.5	5.5	14
Olio (l) / Oil (l) Huile (l) / Öl (l)	0.1	0.15	0.22	0.6	1.1	2.2	3.6	9

È fondamentale non superare le quantità consigliate per evitare surriscaldamenti e sovrappressioni interne, che porterebbero a malfunzionamenti e trafileamenti di lubrificante.

Il est important de ne pas dépasser les quantités conseillées pour éviter de surchauffes et surpressions internes, qui pourraient provoquer des défauts de fonctionnement et suintements de lubrifiant.

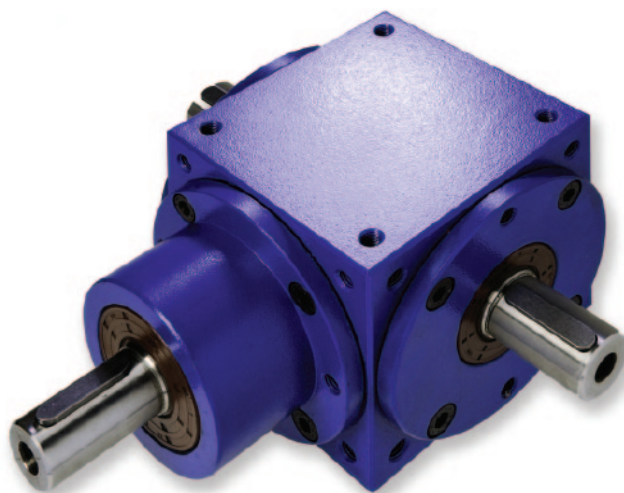
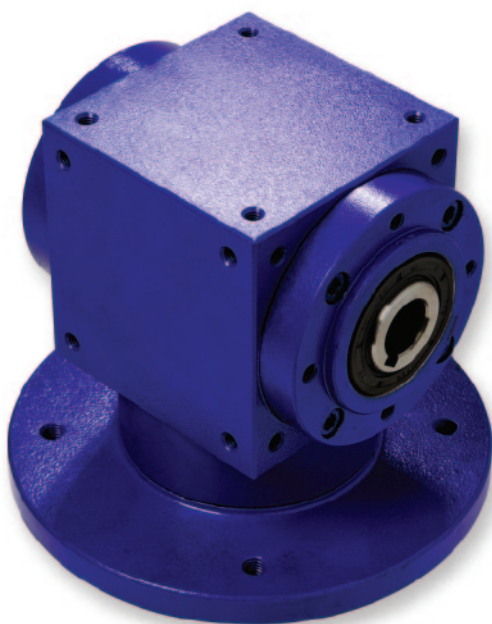

9.1 CARICHI RADIALI (daN) / 9.1 RADIAL LOADS (daN) / 9.1 CHARGES RADIALES (daN) / 9.1 RADIALKRÄFTE - ZULÄSSIG

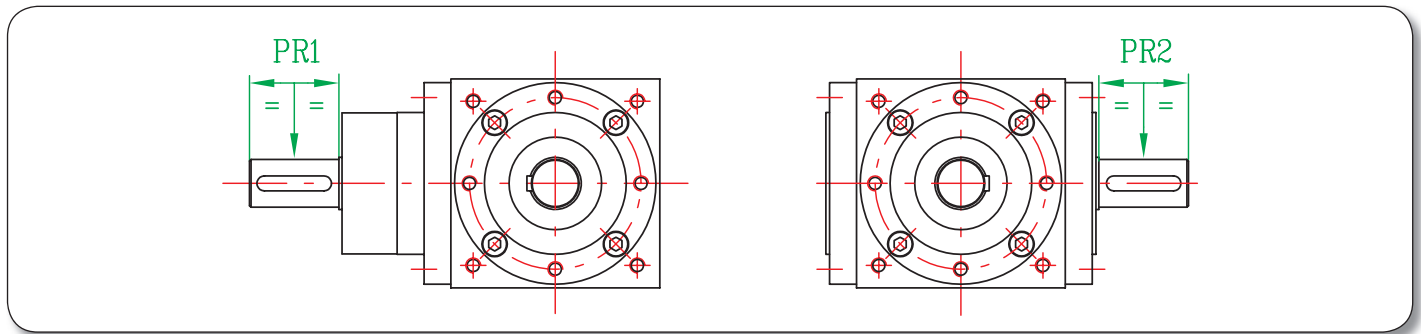

Rapporto / Ratio Rapport / Übersetzung		TAGLIA / UNIT SIZE / TAILLE / BAUTRÖBE							
		BG12	BG19	BG24	BG32	BG38	BG42	BG55	BG75
PR1	1:1, 1:2, 1:3	55	85	140	200	400	600	1000	2500
	1:4, 1:5	-	60	85	140	200	400	600	1000
PR2	Tutti / All Tous / All	90	150	220	350	700	1000	1500	3500

9.2 CARICHI ASSIALI / 9.2 AXIAL LOADS / 9.2 CHARGES AXIALES / 9.2 AXIALKRÄFTE - ZULÄSSIG

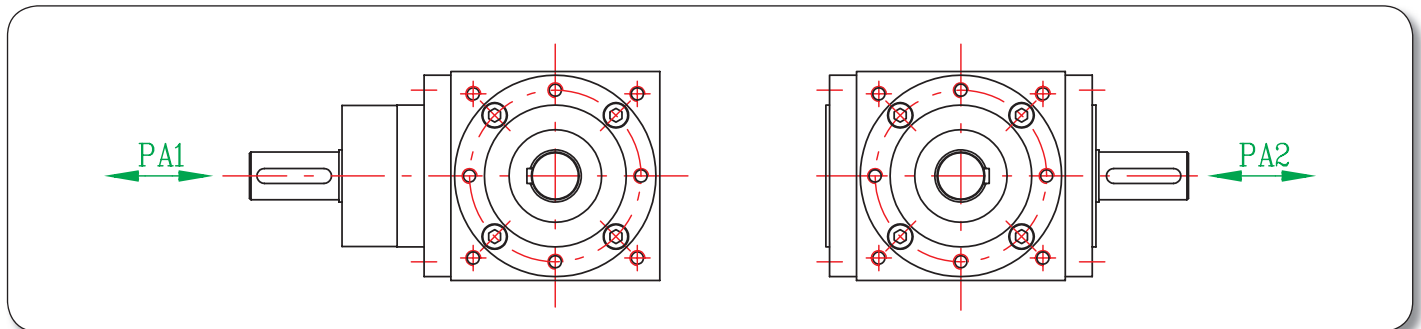

Cuscinetti a sfere / Ball bearing / Roulements à billes / Mit Kugellager

Rapporto / Ratio Rapport / Übersetzung		TAGLIA / UNIT SIZE / TAILLE / BAUTRÖBE							
		BG12	BG19	BG24	BG32	BG38	BG42	BG55	BG75
PA1	1:1, 1:2, 1:3	30	45	70	110	170	270	500	1000
	1:4, 1:5	-	40	45	70	110	170	270	500
PA2	Tutti / All Tous / All	50	70	130	170	340	480	680	1500

Cuscinetti a rulli conici / Taper roller bearing / Roulements à rouleaux coniques / Mit Kugellager

Rapporto / Ratio Rapport / Übersetzung		TAGLIA / UNIT SIZE / TAILLE / BAUTRÖBE							
		BG12	BG19	BG24	BG32	BG38	BG42	BG55	BG75
PA1	1:1, 1:2, 1:3	-	65	100	150	240	400	780	1600
	1:4, 1:5	-	45	65	100	150	240	400	780
PA2	Tutti / All Tous / All	-	100	180	250	500	700	1000	2200



## 10. COPPIA MASSIMA TRASMISSIBILE CON ACCOPPIAMENTI IN SERIE

 Quando più rinvii angolari, di forma A oppure AH, vengono montati in serie occorre sempre verificare che la coppia massima necessaria sia compatibile con quella indicata in tabella.

## 10. SERIES CONNECTION

 When spiral bevel gearboxes type A or AH are mounted in series, the maximum through torque (Nm) mentioned below must not be exceeded.

## 10. COUPLE MAXIMUM TRANSMISSIBLE AVEC DES ACCOUPLEMENTS EN SÉRIE

 Lorsque plusieurs renvois d'angle, forme A ou AH, sont montés en série, il faut toujours vérifier que le couple maximum nécessaire soit compatible avec celui indiqué au tableau.

## 10. HINTEREINANDERSCHALTUNG VON KEGELRADGETRIEBEN

 Werden mehrere Kegelradgetriebe der FORM A oder AH in Reihe montiert, so ist das Höchstdrehmoment aus der Tabelle zu entnehmen:

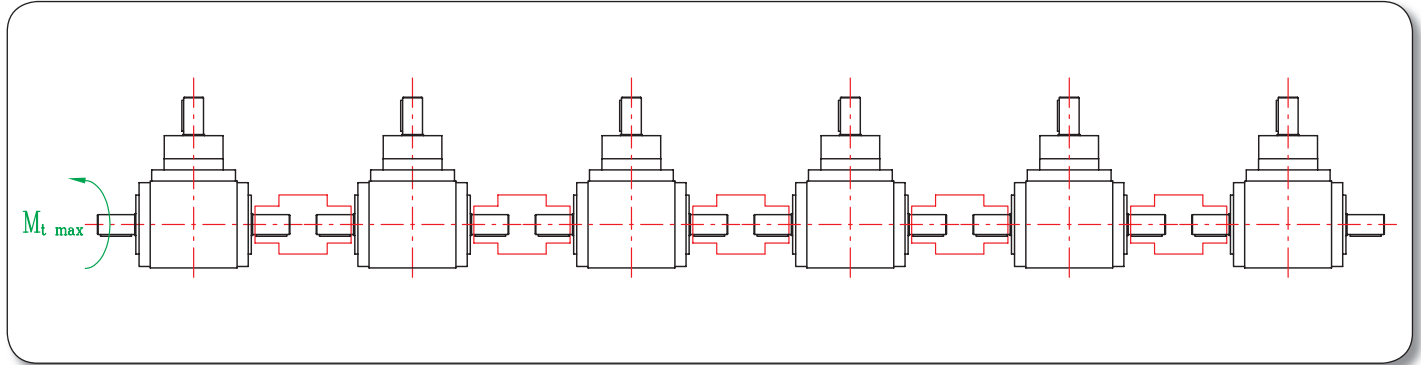

TAGLIA / UNIT SIZE / TAILLE / BAUTRÖBE Forma A/AH / Model A and AH Forme A/AH / Für form A und AH	BG19	BG24	BG32	BG38	BG42	BG55	BG75
Mt max (Nm) / Max. through torque Mt max (Nm) / Mt max (Nm)	60	120	300	500	700	1600	4000

Se invece le condizioni di lavoro sono superiori a quelle sopra indicate, occorre utilizzare rinvii angolari di forma AP con albero di dimensioni maggiorate, le cui coppie massime sono:

If working condition are greater than above type AP gear boxes must be used which have larger shaft diameters.

Si par contre les conditions de travail sont supérieures à celles ci-dessus, il faut utiliser des renvois d'angle ayant la forme AP avec un arbre surdimensionné, dont les couples maximum sont égaux à:

Übersteigen jedoch die Betriebsbedingungen die obengenannten Werte, so ist das Kegelradgetriebe AP mit verstärkter Welle erforderlich. In diesem Fall sind die Höchstdrehmomente wie folgt:

TAGLIA / UNIT SIZE / TAILLE / BAUTRÖBE Forma AP / Model AP Forme AP / Für form AP	BG19	BG24	BG32	BG38	BG42	BG55	BG75
Mt max (Nm) / Max. through torque Mt max (Nm) / Mt max (Nm)	120	300	500	700	1000	3000	6500

**11.1 RINVIO ANGOLARE / 11.1 SPIRAL BEVEL BEARBOXES / 11.1 RENVOI D'ANGLE / 11.1 KEGELRADGETRIEBE**

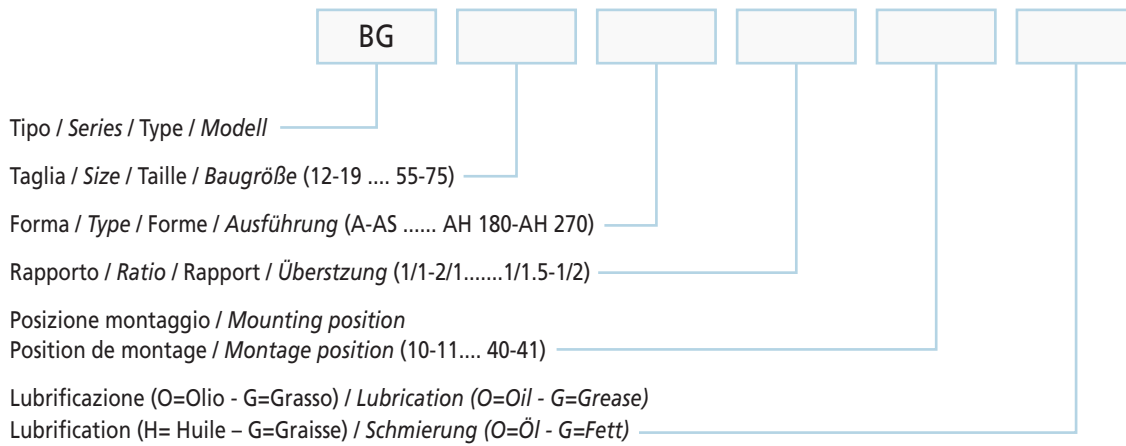

12

**11.2 RINVIO ANGOLARE CON FLANGIATURA MOTORE PAM (vedasi pag. 54-55)**  
**11.2 SPIRAL BEVEL GEARBOXES WITH IEC MOTOR FLANGE ADAPTER (pages 54-55)**  
**11.2 RENVOI D'ANGLE AVEC BRIDAGE MOTEUR PAM (voir pages 54-55)**  
**11.2 KEGELRADGETRIEBE MIT IEC - MOTORFLANSCH (seite 54-55)**

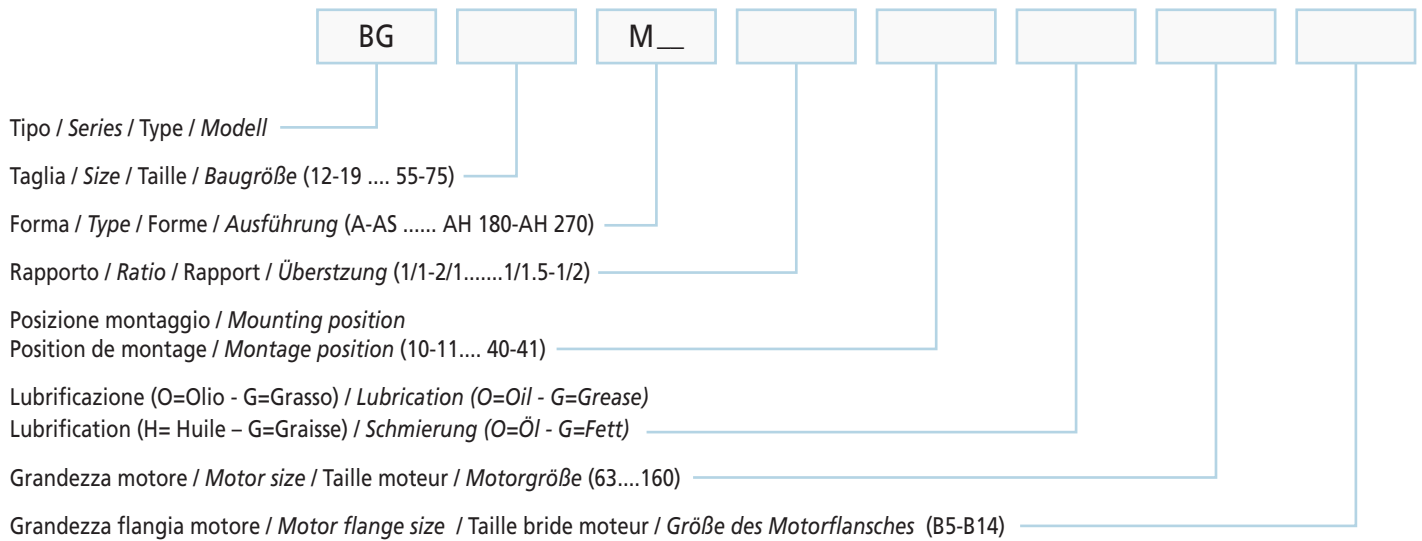



## ISTRUZIONI DI MONTAGGIO, MANUTENZIONE E CONSERVAZIONE

 **Attenzione: leggere la presente guida prima di iniziare qualsiasi operazione di montaggio o manutenzione.**

Nell'unire il presente rinvio agli apparati che si vogliono comandare, e che a sua volta lo comandano, è necessario fare molta attenzione all'allineamento degli assi, in mancanza di questo la meccanica, in particolare i cuscinetti, sarebbero sovraccaricati in modo errato. Questo sovraccarico comporterebbe un maggiore logorio e una diminuzione della durata del gruppo. Il rinvio deve essere fissato ad una superficie abbastanza robusta, tale da impedire allo stesso movimenti, oscillazioni, o vibrazioni ed in grado di sostenerne il peso (pag. 9).

Per il fissaggio dei gruppi utilizzare gli appositi fori filettati presenti sulla scatola, coperchi e mozzi.

N.B: I fori filettati sulla scatola si intersecano tra di loro, non è possibile quindi utilizzare in uno stesso spigolo più viti di fissaggio. Vedi figura a lato.

Prima di montare il rinvio pulire bene le superfici (soprattutto in corrispondenza dei paraoli) per evitare il rischio di ossidazione e grippaggio. Il montaggio deve essere fatto con l'aiuto di tiranti ed estrattori servendosi anche del foro filettato all'estremità di ogni albero.

Per accoppiamenti che prevedano interferenza effettuare un montaggio a caldo, riscaldando l'organo femmina a circa 80 /100°.

I rinvii vengono forniti già lubrificati con grasso a vita per un utilizzo con velocità di ingresso non superiore a 1000 g/min. In tutti gli altri casi è da prevedere lubrificazione ad olio. I rinvii richiesti con lubrificazione ad olio, presentano: un tappo di carico/sfiato, un indicatore del livello di olio e un tappo di scarico. Gli invertitori i disgiuntori e i fasatori vengono di norma forniti lubrificati ad olio questo è dovuto alla presenza di cuscinetti a rullini.

**Tutti i prodotti lubrificati ad olio, sono forniti senza lubrificante.**

L'immissione per ovvie ragioni di sicurezza deve essere effettuata a rinvio fermo. Per le quantità di lubrificante fare riferimento alla tabella di pag. 11.

In ogni caso il livello dell'olio lubrificante all'interno del rinvio, deve essere come indicato nell'immagine a pagina seguente.

Sottolineiamo che immettere più lubrificante del dovuto, **non allunga la vita del rinvio bensì la riduce**. Si vengono a creare sovrappressioni interne, surriscaldamenti e il deperimento delle tenute (paraoli e OR). Tutto ciò causerà perdite di lubrificante che se non rilevate in breve tempo porteranno ad un rapido consumo delle parti in movimento (ingranaggi e cuscinetti). Vi invitiamo pertanto a prestare particolare attenzione a questa semplice ma importante operazione atta a garantire il corretto funzionamento del rinvio nel tempo.

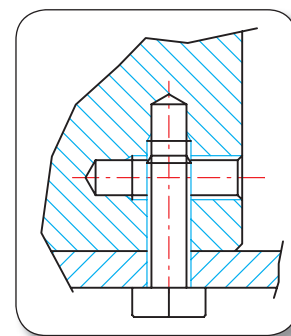

13

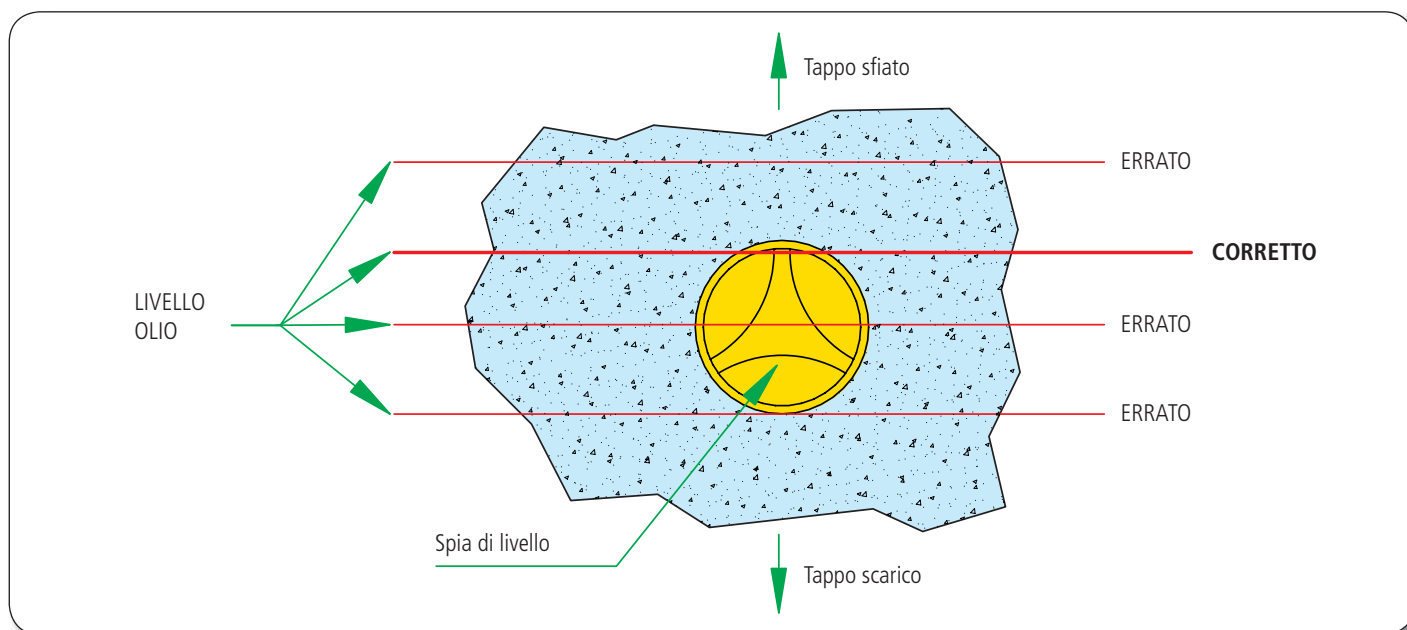

I rinvii devono essere controllati periodicamente, per controllare eventuali perdite di lubrificante dai coperchi o alla base degli alberi, ovvero ove sono presenti le guarnizioni (OR e paraoli).

Nel caso il rinvio sia provvisto di tappo spia controllare che il livello di olio copra completamente la spia, in caso contrario provvedere al rabbocco.

**Sia le operazioni di controllo che quelle di rabbocco sono da effettuarsi a rinvio fermo.**

Gli intervalli di sostituzione dell'olio variano in funzione delle condizioni di lavoro, di norma il lubrificante va sostituito ogni 10.000 ore di lavoro.

Tutti i rinvii da noi assemblati vengono sottoposti ad un breve test per valutarne il corretto montaggio, tuttavia è consigliabile non sottoporlo a sforzi o sovraccarichi eccessivi durante le prime ore di lavoro. Il rinvio raggiunge il suo massimo rendimento solo dopo diverse ore di funzionamento, se necessario esso è in grado di lavorare a pieno carico fin dalle prime ore ma questo va a scapito della durata complessiva.

Bisogna in oltre tenere presente che nel caso si adotti questo tipo di avviamento, durante le prime ore si possono manifestare rumorosità e surriscaldamenti, che andranno gradualmente a diminuire (di norma entro 20-30 ore), questa fase di funzionamento "anomalo" è dovuta agli attriti iniziali dei cuscinetti durante l'assettamento nella sede di rotolamento.

I rinvii lasciati a riposo o inattivi per lunghi periodi devono essere adeguatamente protetti, in modo ancor più accurato se stoccati in atmosfere corrosive o saline. Ruotare periodicamente gli alberi per evitare che la caduta di lubrificante per gravità nella parte inferiore del rinvio lasci scoperta parte degli ingranaggi o dei cuscinetti, queste superfici a contatto prolungato con l'aria potrebbero ossidarsi.

Proteggere gli alberi e le altre superfici esterne (se non trattate) con un velo d'olio.

Qualora si rimetta in servizio un rinvio lubrificato ad olio rimasto inattivo per lungo tempo, si provveda a scaricare l'olio esausto e lo si sostituisca con lubrificante nuovo (fino al livello corretto).



## ASSEMBLY, MAINTENANCE AND STORAGE INSTRUCTIONS

 **Warning:** carefully read this guide before starting any assembly or maintenance operation.

When fitting this gearbox to any controlled and controlling equipment, take special care to axis alignment. Failure to comply with this recommendation would lead to a wrong loading of mechanical parts, bearings in particular. This overload condition would result in an earlier wear and a shorter lifetime of the unit. Gearbox must be secured to quite a strong surface, able to prevent it from moving, swinging or vibrating, and with a suitable loading capacity (see page 9).

To secure gearboxes, use the special threaded holes present on box, covers and hubs.

NOTE: Box threaded holes cross with each other, it will thus not be possible to use several fastening screws on the same edge. See figure at the side.

Before fitting gearbox, thoroughly clean all surfaces – with special care to those close to oil seals – to prevent any oxidation and seizure. Gearboxes must be assembled using special tie-rods and pullers, using also the threaded hole positioned at the end of each shaft. For couplings requiring an interference fitting, proceed to hot assembly by simply heating the female part up to approximately 80° / 100° C.

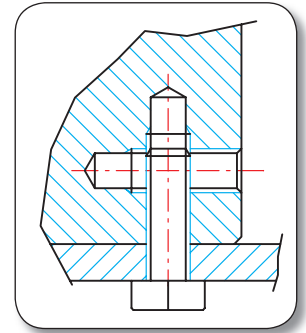

14

Gearboxes are supplied already life-lubricated, based on an input speed not higher than 1,000 RPM. Should they be used under different conditions, they have to be oil lubricated. Gearboxes requiring oil lubrication feature a filling/breather plug, an oil level indicator and a drain plug. Inverters, disengaging units and speed modulation gearboxes are usually supplied already oil-lubricated as they feature needle roller bearings.

**All oil-lubricated products are supplied without any lubricant.** For safety reasons, oil must be filled with the gearbox stopped. For the necessary quantity of lubricant, refer to the table on page 11. As a general rule, the lubricating oil level inside gearbox **must be as shown in the picture on next page.**

We would like to point out that filling gearbox with an excessive quantity of lubricant **does not increase its lifetime, but rather shortens it.**

Internal overpressures, overheating and seal (O-rings and oil seals) wear will lead to lubricating oil leaks that, if not promptly detected, would result in an early wear of moving parts (gears and bearings).

You are thus invited to pay special attention to this simple but important operation so as to ensure gearbox correct operation over time.

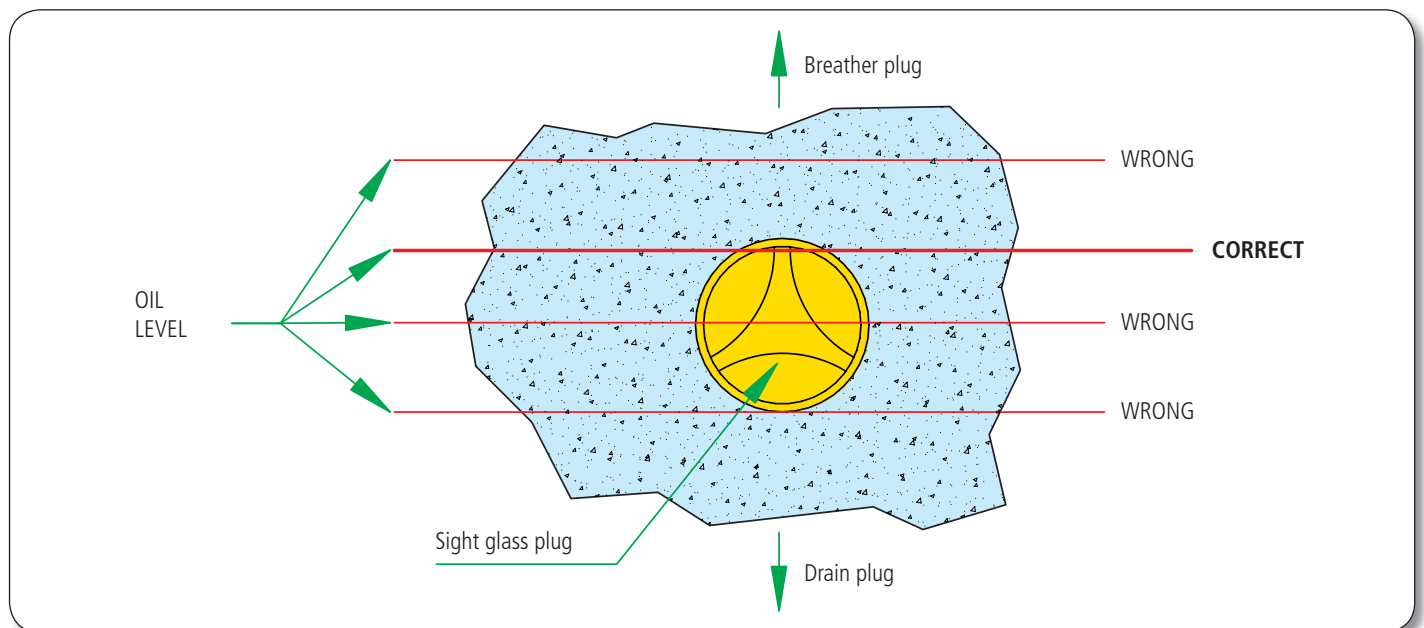

Gearboxes must be subjected to regular inspections to detect any leak of lubricant out of covers or shafts, namely where seals (O-rings and oil seals) are present. If gearbox features a sight glass plug, check that oil level fully covers sight glass; should this not be the case, top up.

**Both check and topping up operations must be carried out with the gearbox stopped.**

Oil change intervals vary based on operating conditions; as a general rule, lubricant must be changed every 10,000 operating hours.

All our gearboxes are shortly tested to check their correct assembly; it is nevertheless advisable not to subject it to excessive efforts or overloads during the first operating hours.

Gearbox reaches its max. performance levels only after several operating hours. If necessary, it can work at full load from the very beginning, but this – of course – will affect its lifetime.

Should gearbox be used under these conditions, high noise levels and overheating could develop during the first operating hours, but they will gradually decrease (usually within 20 to 30 hours). This “abnormal” operation is due to bearing initial friction during bedding-in inside the rolling seat.

Gearboxes left at rest or not used for prolonged times must be duly protected, particularly when stored in corrosive or saline atmospheres.

Rotate shafts at regular intervals to prevent the lubricant falling down due to gravity inside gearbox bottom part from leaving gears or bearings partially uncovered; if exposed for a long time to air, these surfaces could oxidize.

Protect shafts and the other outer surfaces (if not treated) with a thin layer of oil.

Should an oil-lubricated gearbox left unused for a long time be used again, drain it from all exhausted oil and fill it with new lubricant (up to correct level).



## INSTRUCTIONS DE MONTAGE, ENTRETIEN ET CONSERVATION

 **Attention: lire ce guide avant de commencer toute opération de montage ou entretien.**

Durant la phase d'assemblage du renvoi aux appareillages que l'on veut commander, et qui à leur fois le commandent, il est nécessaire de prêter attention à l'alignement des axes, sinon la mécanique, surtout les roulements seront soumis à des surcharges inappropriées. Cette surcharge peut amener à un usage plus important et à une diminution de la durée du groupe. Le renvoi doit être fixé à une surface suffisamment robuste, pour empêcher que ce dernier soit intéressé par des mouvements, oscillations et vibrations et qui soit capable de soutenir son poids (page 9).

Pour le fixage des groupes il faut utiliser les trous taraudés spéciaux qui se trouvent sur la boîte, couvercles et moyeux. N.B. Les trous taraudés sur la boîte se croisent entre eux, il n'est pas possible donc d'utiliser sur le même coin plusieurs vis de fixation. Voir figure ci-contre.

Avant de monter le renvoi nettoyer avec attention les surfaces (surtout près des joints d'huile) pour éviter le risque d'oxydation et grippage. Le montage doit être effectué à l'aide des tirants et extracteurs en se servant aussi du trou taraudé fixé à l'extrémité de chaque arbre.

Pour les accouplements qui prévoient une interférence effectuer un montage à chaud, en réchauffant l'organe femelle à une température d'environ 80°/ 100°. Les renvois sont fournis déjà lubrifiés avec lubrification permanente pour être employés avec une vitesse d'entrée non supérieure à 1 000 g/min. Dans tous les autres cas il est nécessaire une lubrification à l'huile.

Les renvois demandés avec lubrification à l'huile présentent : un bouchon de remplissage/évent, un indicateur du niveau de l'huile et un bouchon de vidange. Les variateurs, les disjoncteurs et les déphaseurs sont normalement fournis lubrifiés à l'huile, cela est dû à la présence des roulements à aiguilles.

### Tous les produits lubrifiés à l'huile sont fournis sans lubrifiant.

L'introduction de l'huile pour des raisons évidentes de sécurité doit être effectuée renvoi à l'arrêt. Pour les quantités de lubrifiant faire référence au tableau de page 11. En tout cas le niveau de l'huile lubrifiant à l'intérieur du renvoi **doit être égal à celui indiqué dans l'image située à la page suivante.**

On remarque qu'introduire trop de lubrifiant ne prolonge pas la vie du renvoi, au contraire il la réduit (joints d'huile et joints toriques), tout cela causera des pertes de lubrifiant qui si ne sont pas relevées dans un court délai amèneront à une usure rapide des parties en mouvement (engrenages et roulements).

Nous vous invitons, par conséquent, à prêter une attention particulière à cette opération simple mais importante pour garantir le fonctionnement correct du renvoi dans le temps.

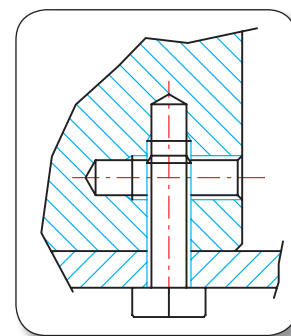

15

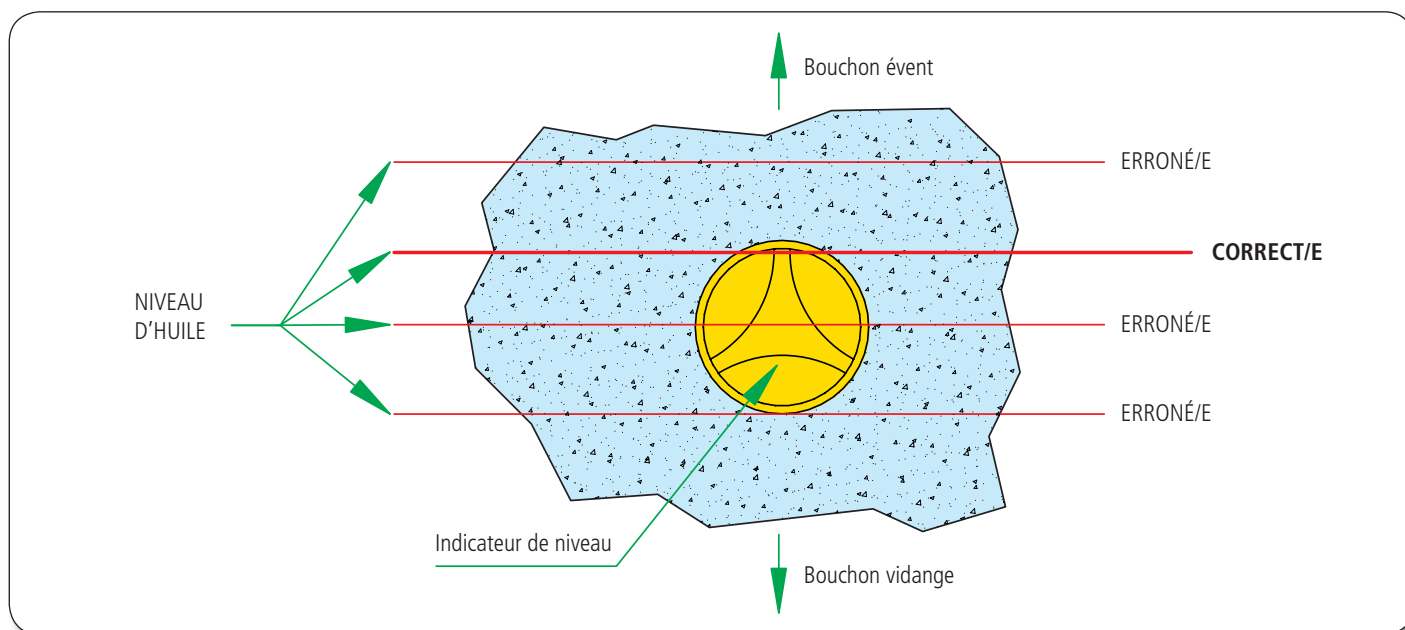

Les renvois doivent être contrôlés périodiquement pour vérifier les pertes éventuelles de lubrifiants depuis les couvercles ou à la base des arbres, soit où il y a des joints (joints toriques et joints d'huile).

Dans le cas où le renvoi serait doté d'un bouchon indicateur, contrôler que le niveau de l'huile couvre complètement l'indicateur, dans le cas contraire remettre à niveau. **Aussi bien les opérations de contrôle que celle de remise à niveau doivent être effectuées renvoi à l'arrêt.**

Les intervalles de renouvellement de l'huile varient en fonction des conditions de travail, normalement le lubrifiant doit être changé toutes les 10 000 heures de travail. Tous les renvois montés par nous sont soumis à un test de courte durée pour en évaluer le montage correct, pourtant il est conseillé de ne le pas soumettre à des efforts ou surcharges excessifs durant les premières heures de travail.

Le renvoi atteint son rendement maximum uniquement après plusieurs heures de fonctionnement, si nécessaire, il est capable de travailler à pleine charge dès les premières heures mais cela se fait au détriment de la durée totale.

Il faut en outre considérer que dans le cas où l'on adopterait ce type de démarrage, durant les premières heures peuvent se manifester des bruits et surchauffes, qui diminueront graduellement (normalement dans les 20-30 heures), cette phase de fonctionnement « anormal » est dû aux frictions initiales des roulements pendant la mise en place dans les chemins de roulement.

Les renvois laissés en repos ou inactifs pour des longues périodes doivent être correctement protégés, de manière encore plus soignée si stockés dans des atmosphères corrosives ou salines.

Tourner périodiquement les arbres pour éviter que la chute de lubrifiant due à la gravité dans la partie inférieure du renvoi laisse découverte une partie des engrenages et des roulements, ces surfaces à contact prolongé avec l'air pourraient s'oxyder.

Protéger les arbres et les autres surfaces externes (si non traités) avec un voile d'huile.

Lorsque un renvoi lubrifié à l'huile se remet en service après longtemps d'inactivité, faire la vidange et renouveler l'huile avec du lubrifiant neuf (jusqu'au niveau correct).



## MONTAGE-, WARTUNGS- UND EINLAGERUNGSANLEITUNGEN

 **Achtung: Lesen Sie diese Anleitung vor Beginn irgendwelcher Montage- oder Wartungsarbeiten durch.**

Bei der Montage dieses Vorgeleges an die von ihm zu steuernden Geräte sowie an seine Steuergeräte muss besonderer Wert auf die Fluchtung der Achsen gelegt werden. Ist diese nicht gegeben, würde es zu einer falschen Belastung bzw. Überbelastung der Mechanik, insbesondere der Lager kommen. Diese Überbelastung würde einen erhöhten Verschleiß und eine verminderte Standzeit der Einheit zur Folge haben.

Um Bewegungen, ein Schwingen oder Vibrationen vermeiden zu können, muss das Vorgelege an einer ausreichend robusten Fläche befestigt werden, die in der Lage ist, das Gewicht (Seite 9) zu tragen.

Zum Befestigen der Einheiten sind die entsprechenden Gewindebohrungen zu verwenden, die im Gehäuse, in den Deckeln und Naben vorhanden sind.

HINWEIS: Die im Gehäuse vorhandenen Gewindebohrungen überschneiden sich, daher ist es nicht möglich, an ein und derselben Kante mehrere Befestigungsschrauben zu verwenden. Siehe nebenstehende Abbildung.

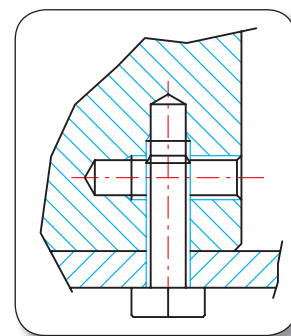

Vor der Montage des Vorgeleges müssen die Passflächen (insbesondere an den Ölabdichtungen) gut gereinigt werden, so dass die Gefahren von Oxydation und Fressen vermieden werden können. Die Montage muss unter Zuhilfenahme von Zugstangen und Abziehern erfolgen, wobei auch die Bohrungen an Ende der jeweiligen Wellen zu nutzen sind.

Bei Passungen, die eine Interferenz vorsehen, muss die Montage im warmen Zustand erfolgen. Das Aufsteckteil dafür auf ungefähr 80° / 100° erwärmen. Die Vorgelege, die eine Antriebsdrehzahl von 1000 U/min nicht überschreiten, werden bereits auf Lebensdauer mit einer Fettmenge gefüllt geliefert. Andernfalls ist eine Ölschmierung vorzusehen. Die mit einer Ölschmierung angeforderten Vorgelege verfügen über: eine Einfüll-/Entlüftungsschraube, eine Füllstandanzeige und eine Ablassschraube. Die Wechselrichter, Entkopplungs- und Gleichrichter werden üblicherweise mit Öl geschmiert, da hier Nadellager vorhanden sind.

**Alle mit Öl geschmierten Produkte werden ohne Schmiermittel geliefert.** Das Einfüllen muss aus eindeutigen Sicherheitsgründen an einem stehenden Vorgelege erfolgen. Die erforderlichen Schmiermittelmengen können der Tabelle auf Seite 11 entnommen werden.

Auf jeden Fall **muss** der Schmierölstand im Vorgelege **dem in der Abbildung auf nachstehender Seite angegebenen entsprechen.**

Wir weisen darauf hin, dass das Einfüllen einer höheren Schmiermittelmenge als die erforderliche die **Standzeit des Vorgeleges nicht verlängert, sondern verkürzt.** In diesem Fall würde es zu einem internen Überdruck, Überhitzungen und dem Zerfall der Dichtungen (Ölabdichtungen und O-Ringe) kommen, was dann zu Schmiermittelleckagen führt, die, falls nicht in kurzer Zeit erfasst, einen schnellen Verschleiß der sich in Bewegung befindlichen Teile (Zahnräder und Lager) verursachen. Wir bitten Sie daher auf diesen einfachen jedoch wichtigen Arbeitsschritt, welcher dem korrekten Betrieb des Vorgeleges über die Zeit hinweg dient, besondere Aufmerksamkeit zu richten.

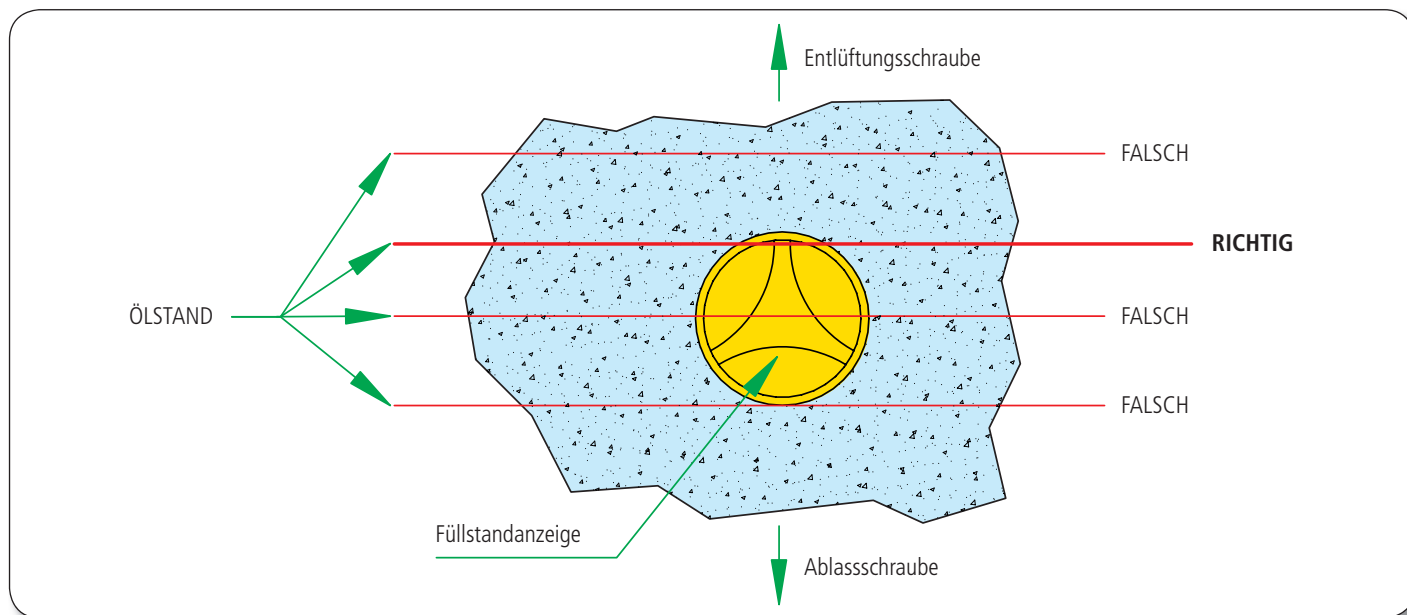

Die Vorgelege müssen regelmäßig kontrolliert werden, so dass eventuelle Schmiermittelleckagen an den Deckeln oder an Wellenenden bzw. dort wo Dichtungen (Ölabdichtungen und O-Ringe) verbaut wurden, erfasst werden können. Sollte das Vorgelege mit einer Füllstandanzeige versehen sein, muss kontrolliert werden, dass der Ölstand diese vollkommen abdeckt. Andernfalls muss Öl nachgefüllt werden. **Sowohl die Kontrollen als auch das Nachfüllen müssen bei stehendem Vorgelege ausgeübt werden.** Die Ölwechselfälligkeiten variieren in Abhängigkeit der Betriebsbedingungen; normalerweise muss das Schmiermittel alle 10.000 Betriebsstunden ausgewechselt werden. Alle von uns montierten Vorgelege werden einem kurzen Test unterzogen, so dass bewertet werden kann, ob die Montage korrekt erfolgt ist. Es wird dennoch empfohlen, es in den ersten Betriebsstunden keinen übermäßigen Kraftaufwendungen oder Belastungen auszusetzen. Das Vorgelege erreicht seine maximale Leistungsfähigkeit erst nach einigen Betriebsstunden, doch im erforderlichen Fall kann es bereits in den ersten Einsatzstunden der vollen Belastung ausgesetzt werden, was allerdings zu Lasten der Gesamtstandzeit geht. Darüber hinaus muss berücksichtigt werden, dass es im Fall eines solchen Anlaufs in den ersten Stunden zu Geräuschbildungen und Überhitzungen kommen kann, die daraufhin schrittweise abnehmen (im Allgemeinen innerhalb von 20 – 30 Stunden). Diese „anormale“ Betriebsphase lässt sich auf die anfänglichen Reibungen der Lager während des Setzens ihrem Sitz zurückführen.

Über lange Zeit hinweg im Ruhe- oder ungenutzten Zustand belassene Vorgelege müssen **in angemessener Weise geschützt** werden. Dies erweist sich dem Fall als besonders wichtig, in dem sie in korrosiv wirkenden und salzhaltigen Atmosphären gelagert werden.

Die Wellen regelmäßig drehen, um zu vermeiden, dass der aufgrund der Schwerkraft stattfindende Fall des Schmiermittels in den unteren Bereich des Vorgeleges zum Freilegen von Zahnrad- oder Lagerteilen führt, da deren Oberflächen bei längerem Kontakt mit der Luft rosten könnten.

Die Wellen und anderen (unbehandelten) Außenflächen mit etwas Öl schützen.



Wird ein länger eingelagertes und mit Öl geschmiertes Vorlege erneut in Betrieb genommen, muss das Altöl abgelassen und durch frisches Schmiermittel ersetzt werden (bis auf korrekten Füllstand füllen).

12.1 RINVIO ANGOLARE CON ALBERO PASSANTE A, AD, AS - B, BD, BS / 12.1 BEVEL GEARBOX TYPE A, AD, AS - B, BD, BS

12.1 RENVOI D'ANGLES AVEC ARBRE TRAVERSANT A, AD, AS - B, BD, BS / 12.1 KEGELRADGETRIEBE (A, AD, AS - B, BD, BS) MIT DURCHGANGSWELLE

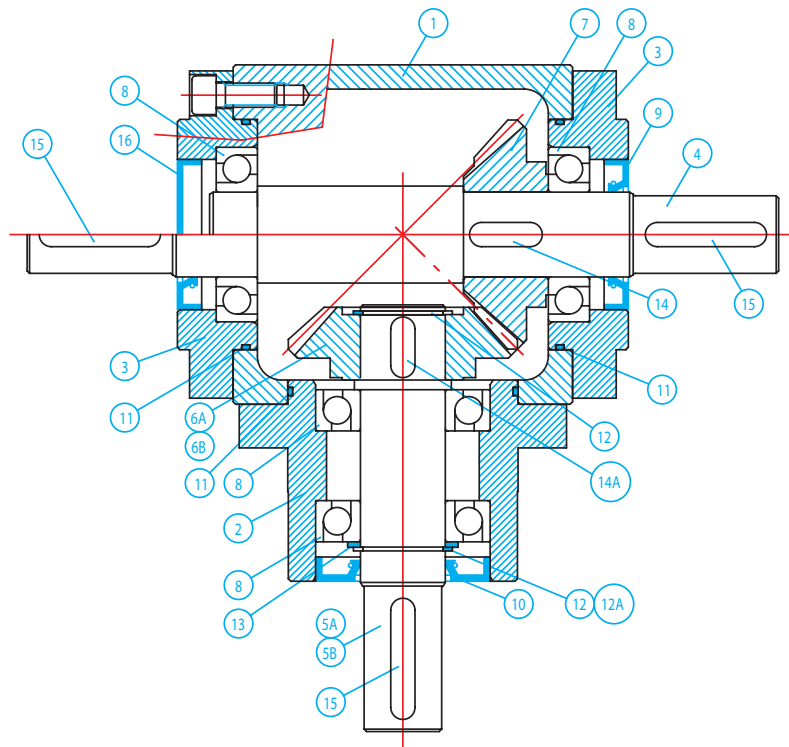

Pos.	Denominazione / Description Dénomination / Bezeichnung	BG12	BG19	BG24	BG32	BG38	BG42	BG55	BG75
1	Scatola forma A-B / Bevel gearbox A-B Boîte forme A-B / Gehäuseform A-B	2001BGxxA - 2001BGxxB							
2	Mozzo / Input housing / Moyeu / Nabe	4002BGxx							
3	Coperchio / Output cover / Couvercle / Deckel	4001BGxx							
4	Albero passante A-AD-AS / Extended shaft A-AD-AS Arbre traversant A-AD-AS / Durchgangswelle A-AD-AS	3001BGxxA - 3001BGxxAD - 3001BGxxAS							
5A	Albero mozzo 1:1 / Shaft for pinion Arbre moyeu / Nabenwelle	--	--	--	--	--	--	--	3002BG75
5B	Albero mozzo 1:4 1:5 / Shaft for pinion Arbre moyeu / Nabenwelle	--	--	--	300245BG32	300245BG38	300245BG42	300245BG55	300245BG75
6A	Pignone conico 1:1 / Bevel pinion Pignon conique / Kegelradritzel	5111BGxxINT (Pignone conico integrale / Integrated bevel sprocket Pignon conique intégré / Antriebskegelrad)							
6	Pignone conico 1:2 1:3 1:4 1:5 / Bevel pinion Pignon conique / Kegelradritzel	51yyBGxx							
7	Corona conica / Bevel wheel Couronne conique / Kegelrad	52yyBGxx							
8	Cuscinetto / Ball bearing / Roulement / Lager	6003-2Z	7204	7205	7207	7209	7209	7212	7317
9	Paraolio / Oil seal / Joint d'huile / Dichtring	17x28x7	20x40x7	25x45x10	35x62x7	45x72x10	45x72x10	60x90x10	85x110x12
10	Paraolio / Oil seal / Joint d'huile / Dichtring	17x35x7	20x47x7	25x52x10	35x72x10	45x85x10	45x85x10	60x110x12	80x110x12
11	Anello OR / O-Ring / Joint torique / O-Ring	3150	2225	3275	3350	3475	4525	4675	3925
12	Anello SEEGER / Circlip / Jonc SEEGER / Seegerring	--	--	--	--	--	--	--	85 E
12A	Ghiera / Ring nut / Baque / Nutmutter	17 E	20 E	25 E	35 E	45 E	45 E	60 E	GADM085
13	Rasamento assiale / Axial shim Cale axiale / Axial-Zwischenscheibe	SS17x24x1.5	LS 20x35	LS 25x42	LS 35x52	SS 45x55x3	SS 45x55x3	SS 60x75x3	--
14	Chiavetta / Key / Clavette / Keil	5x5x12	6x6x20	8x7x25	10x8x30	12x8x35	14x9x40	18x11x50	22x14x70
14A	Chiavetta / Key / Clavette / Keil	--	--	--	--	--	--	--	22x14x70
15	Chiavetta / Key / Clavette / Keil	4x4x20	6x6x35	8x7x40	10x8x50	10x8x60	12x8x70	16x10x100	20x12x140
15	Tappo di tenuta / Bung Bouchon d'étanchéité / Dichtung	28	40	45	52	72	72	90	--

xx = Grandezza del rinvio / Size / Taille du renvoi / Bauggröße des Kegelradgetriebes (12-19...55-75)

yy = Rapporto / Ratio / Rapport / Übersetzungsverhältnis (11=1/1 - 12=2/1 - 13=3/1 - 14=4/1 - 15=5/1)

In tutte le grandezze per i rapporti di trasmissione diversi da 1:1 1:4 1:5 il pignone è sempre di pezzo con l'albero mozzo.

On gear units of all sizes, for drive ratios other than 1:1 1:4 1:5, sprocket is always integrated with hub shaft.

Dans toutes les tailles pour les rapports de transmission autres que 1:1 1:4 1:5, le pignon est toujours une pièce unique avec l'arbre moyeu.

In allen Größen ist der Ritzel für andere Übertragungsverhältnisse als 1:1 1:4 1:5 stets ein Stück mit der Radnabenwelle.



**12.2 RINVII ANGOLARI CON ALBERO CAVO E ALBERO PASSANTE RINFORZATO**  
**12.2 BEVEL GEARBOX WITH HOLLOW SHAFT (AH) AND REINFORCED EXTENDED SHAFT (AP)**  
**12.2 RENVOI D'ANGLES AVEC ARBRE CREUX E ARBRE TRAVERSANT RENFORCÉ**  
**12.2 KEGELRADGETRIEBE MIT HOHLWELLE [AH] UND VERSH:IRKTER DURCHGANGSWELLE [AP]**

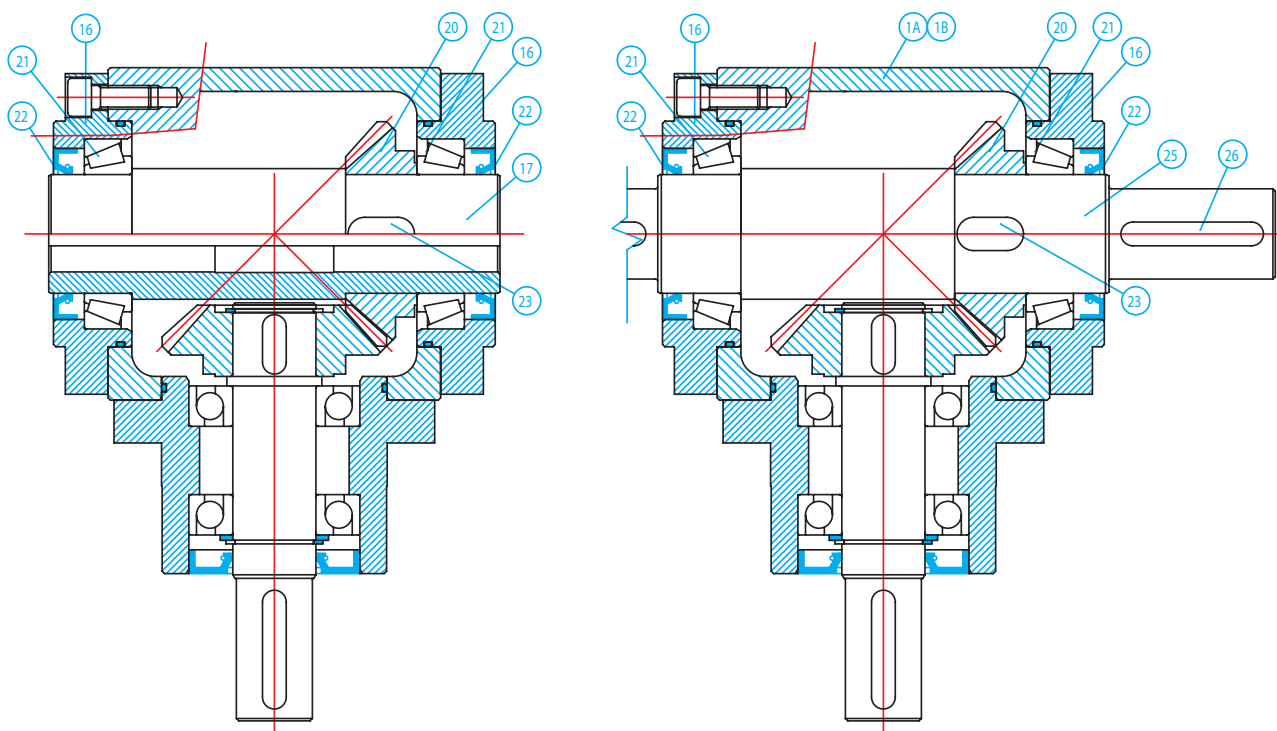

Pos.	Denominazione / Description Dénomination / Bezeichnung	BG12	BG19	BG24	BG32	BG38	BG42	BG55	BG75
16	Coperchio / Output cover Couvercle / Deckel	4013BGxx							
17	Albero cavo / Hollow shaft Arbre creux / Hohlwelle	3004BGxx							
25	Albero rinforzato / Reinforced shaft Arbre renforcé / Verstärkte Welle	--	3001BGxxP						
20	Corona conica / Bevel wheel Couronne conique / Kegelrad	52yyBGxxH							
21	Cuscinetto / Ball bearing Roulement / Lager	61904	32006X	32007X	32010X	32012X	32012X	32015X	33024X
22	Paraolio / Oil seal Joint d'huile / Dichtring	20x30x7	30x47x8	35x55x10	50x72x10	60x90x10	60x90x10	75x100x10	120x150x12
23	Chiavetta / Key / Clavette / Keil	4x4x12	8x7x18	10x8x25	14x9x28	14x9x30	14x9x40	16x10x55	22x10x70
26	Chiavetta / Key / Clavette / Keil	--	8x7x40	10x8x50	10x8x60	12x8x70	14x9x80	20x12x100	25x14x140

xx = Grandezza del rinvio / Size / Taille du renvoi / Baugroße des Kegelradgetriebes (12-19...55-75)  
yy = Rapporto / Ratio / Rapport / Übersetzungsverhältnis (11=1/1 - 12=2/1 - 13=3/1 - 14=4/1 - 15=5/1)

Per i componenti non citati valga la distinta ricambi di pag. 17.  
For any parts not mentioned here, parts list on page 17 shall apply.  
Pour les composants non mentionnés se reporter à la liste des pièces détachées à page 17.  
Für die nicht angeführten Bauteile gilt die Ersatzteilliste auf Seite 17.



**12.3 RINVIO ANGOLARE CON FLANGIATURA MOTORE PAM**  
**12.3 BEVEL GEARBOX WITH IEC MOTOR FLANGE ADAPTER (M)**  
**12.3 RENVOI D'ANGLES AVEC BRIDAGE MOTEUR PAM**  
**12.3 KEGELRADGETRIEBE MIT IEC MOTORFLANSCH**

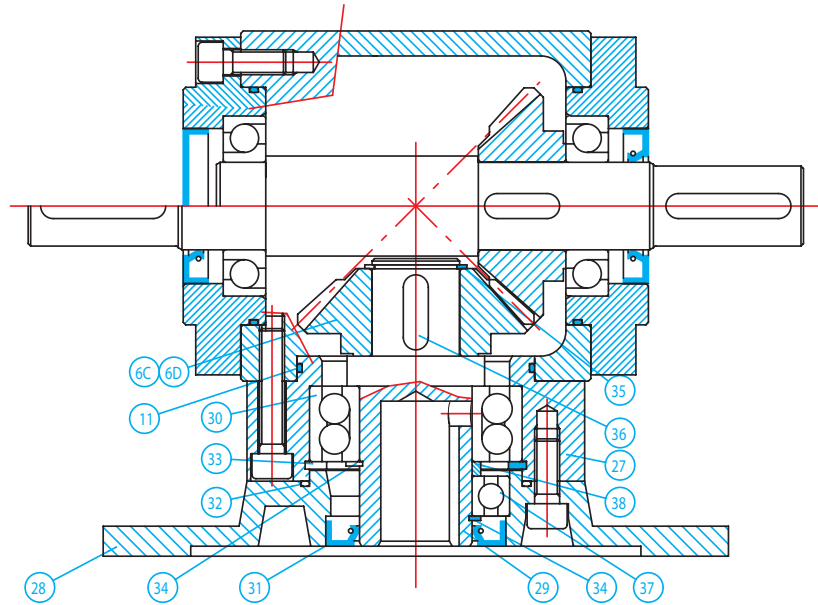

Pos.	Denominazione / Description Dénomination / Bezeichnung	BG12	BG19	BG24	BG32	BG38	BG42	BG55	BG75
6C	Pignone conico 1:1 / Bevel pinion Pignon conique / Kegelradritzel	5111BG12PAM	5111BG19	5111BG24H	5111BG32H	5111BG38	5111BG42	5111BG55	--
6D	Pignone conico 1:2 1:3 1:4 1:5 / Bevel pinion Pignon conique / Kegelradritzel	51yyBGxxDzzz							--
27	Mozzo / Input housing / Moyeu / Nabe	--	4014BGxx						
28	Flangia motore / Motor flange Bride moteur / Motorflansch	83BGxxDzzz							
29	Albero motore 1.1 / Drive shaft Arbre moteur / Motorwelle	3006BGxxDzzz							
30	Cuscinetto / Ball bearing / Roulement / Lager	6003	3205	3207	3209	3211	3212	3214	--
31	Paraolio / Oil seal / Joint d'huile / Dichtring	25x47x7	25x40x7	35x62x7	45x72x10	55x90x10	60x110x10	70x110x12	--
32	Anello OR / O-Ring / Joint torique / O-Ring	--	2212	2287	3325	3400	4437	4500	--
33	Anello SEEGER interni / Internal snap ring Jonc SEEGER intérieurs / SEEGERRING intern	--	52 I	72 I	85 I	100 I	110 I	125 I	--
34	Anello SEEGER esterni / External snap ring Jonc SEEGER extérieurs / SEEGERRING extern	25 E	25 E	35 E	45 E	55 E	60 E	70 E	--
35	Anello SEEGER esterni / External snap ring Jonc SEEGER extérieurs / SEEGERRING extern	17 E	20 E	25 E	35 E	45 E	45 E	60 E	--
36	Anello SEEGER esterni / External snap ring Jonc SEEGER extérieurs / SEEGERRING extern	5x5x12	6x6x20	8x7x25	10x8x30	12x8x35	14x9x40	18x11x50	--
37	Cuscinetto / Ball bearing / Roulement / Lager	6005	--	--	--	--	6012	6014	--
38	Distanziale / Spacer Cale d'espacement / Distanzstück	--	--	--	--	--	84BG42	84BG55	--

xx = Grandezza del rinvio / Size / Taille du renvoi / Baugroße des Kegelradgetriebes (12-19....55-75)

yy = Rapporto / Ratio / Rapport / Übersetzungsverhältnis (11=1/1 - 12=2/1 - 13=3/1 - 14=4/1 - 15=5/1)

zzz = Grandezza motore PAM / IEC motor frame size / Taille moteur PAM / Größe PAM Motor (063.....160)

Per la grandezza BG12, il mozzo pos. "27" non esiste in quanto realizzato unitamente con la flangia motore pos. "28".

For size BG12, hub pos. "27" is not available since it is manufactured together with motor flange pos. "28".

Pour la taille BG12, le moyeu de pos. « 27 » n'existe pas, celui-ci formant une pièce unique avec la bride du moteur de pos. « 28 ».

Für die Größe BG12 existiert die Radnabe „27“ nicht, da sie zusammen mit dem Motorflansch Pos. „28“ realisiert ist.



## DIMENSIONI D'INGOMBRO / DIMENSIONS / DIMENSIONS D'ENCOMBREMENT / MAßE

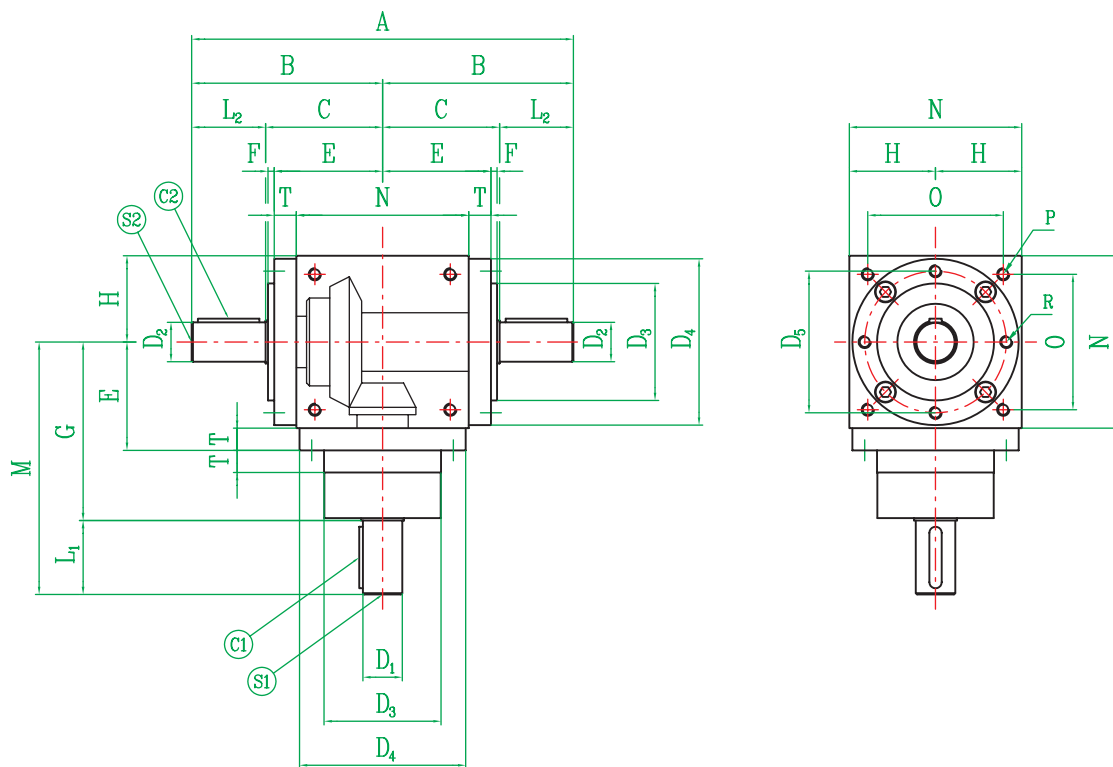

Taglia Size Taille Bautgröße	Rapporto Ratio Rapport Übersetzung	A	B	C	D <sub>1</sub>	D <sub>2</sub>	D <sub>3</sub>	D <sub>4</sub>	D <sub>5</sub>	E	F	G	H	L <sub>1</sub>	L <sub>2</sub>
BG12	1, 2, 3	144	72	46	12 j6	12 j6	44 h7	65 **	54	42	2	74	32.5	26	26
BG19	1, 2, 3	210	105	65	19 j6	19 j6	60 h7	86 h7	72	59	4	100	45	40	40
	4, 5				14 j6									30	
BG24	1, 2, 3	260	130	80	24 j6	24 j6	70 h7	105 h7	88	73	5	115	55	50	50
	4, 5				19 j6									40	
BG32	1, 2, 3	310	155	95	32 j6	32 j6	95 h7	135 h7	115	88	5	145	70	60	60
	4, 5				24 j6									50	
BG38	1, 2, 3	360	180	110	38 j6	38 j6	120 h7	165 h7	145	103	5	170	85	70	70
	4, 5				28 j6									60	
BG42	1, 2, 3	410	205	125	42 j6	42 j6	135 h7	190 h7	165	118	5	195	100	80	80
	4, 5				32 j6									60	
BG55	1, 2, 3	520	260	150	55 j6	55 j6	170 h7	230 h7	205	143	5	245	120	110	110
	4, 5				42 j6									80	
BG75	1, 2, 3	750	375	225	75 j6	75 j6	220 *	300 h7 *	--	195	16	350	165	150	150
	4, 5				55 j6		110								

\* Nel caso del rinvio angolare BG75 se occorre centrarsi su questo diametro chiedere informazioni al nostro ufficio tecnico / For spiral bevel gearbox BG75, please request further information to our engineering dept. to be able to centre on this diameter / Dans le cas du renvoi d'angle BG75, s'il faut que le centrage se produise sur ce diamètre, faire appel à notre service d'assistance technique / Sollte es im Falle des Winkel-Vorgeleges BG75 erforderlich sein, sich auf diesen Durchmesser zu zentrieren, sind bei unserer technischen Abteilung Informationen einzuholen.





\*\* Il diametro non è in tolleranza / Diameter is out of tolerance / Le diamètre n'est pas en tolérance / Der Durchmesser ist nicht in Toleranz.



**POSIZIONI DI MONTAGGIO / MOUNTING POSITION**  
**POSITIONS DE MONTAGE / EINBAULAGEN - KEGELRADGETRIEBE**

Schema superiore: Vista dal fianco - Schema inferiore: Vista dall'alto  
 Top diagram: Side view - Bottom diagram: Top view  
 Schéma supérieur: Vu de côté - Schéma inférieur: Vue d'en haut  
 Seitenansicht - Draufsicht

	Sfiato / Breather plug Évent / Einfüll Entlüftungsstopfen
	Livello / Level plug Niveau / Ölstandanzeige
	Scarico / Drain plug Vidange / Ablasschraube

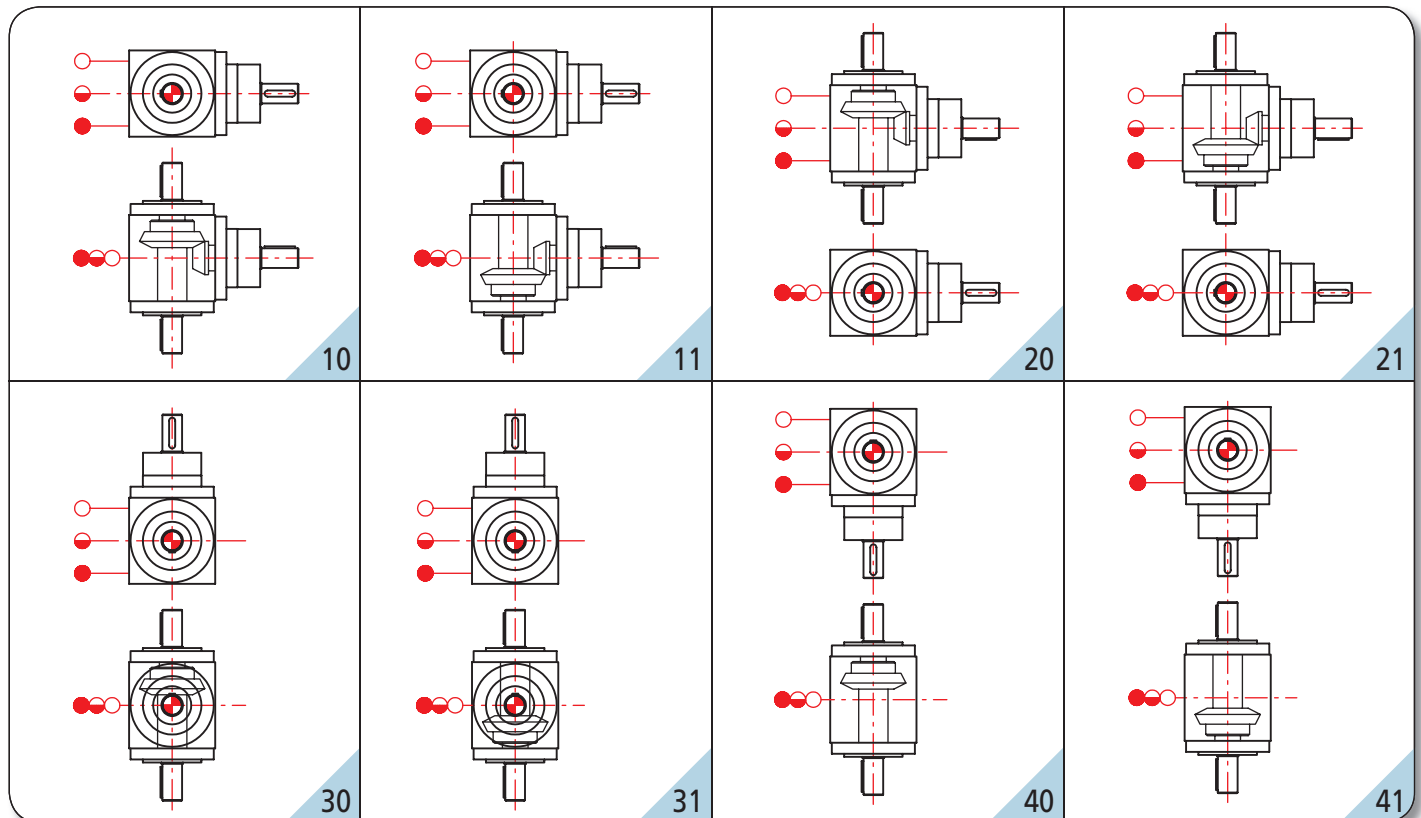

21

Taglia Size Taille Bautröße	Rapporto Ratio Rapport Übersetzung	M	N	O	P	R	S1	S2	C1	C2	T
BG12	1, 2, 3	100	65	45	M6 ***	M6	M4x8	M4x8	20x4x4	20x4x4	9.5
BG19	1, 2, 3	140	90	70	M6	M6	M6x12	M6x12	35x6x6	35x6x6	14
	4, 5	130					M5x10		25x5x5		
BG24	1, 2, 3	165	110	88	M8	M8	M8x16	M8x16	40x8x7	40x8x7	18
	4, 5	155					M6x12		35x6x6		
BG32	1, 2, 3	205	140	110	M10	M10	M10x20	M10x20	50x10x8	50x10x8	18
	4, 5	195					M8x16		40x8x7		
BG38	1, 2, 3	240	170	136	M12	M12	M12x24	M12x24	60x10x8	60x10x8	18
	4, 5	230					M10x20		50x8x7		
BG42	1, 2, 3	275	200	155	M12	M12	M12x24	M12x24	70x12x8	70x12x8	18
	4, 5	255					M10x20		50x10x8		
BG55	1, 2, 3	355	240	190	M14	M14	M14x28	M14x28	100x16x10	100x16x10	23
	4, 5	325					M12x24		70x12x8		
BG75	1, 2, 3	500	330	248	M16	M16	M16x32	M16x32	140x20x14	140x20x14	30
	4, 5	460					M14x28		100x16x10		

\*\*\* Nella grandezza BG12 i fori "P" di interasse "O" sono presenti solamente sulle facce libere.  
 On BG12 size the holes P at centres O are only available on the side.  
 Dans la taille BG12 les trous «P» d'entraxe «O» sont présents seulement sur les côtés libres.  
 Bei der Baugröße BG12 sind die Bohrungen P mit dem Lochabstand O nur auf den Seiten ohne Wellen vorhanden.



## DIMENSIONI D'INGOMBRO / DIMENSIONS / DIMENSIONS D'ENCOMBREMENT / MAßE

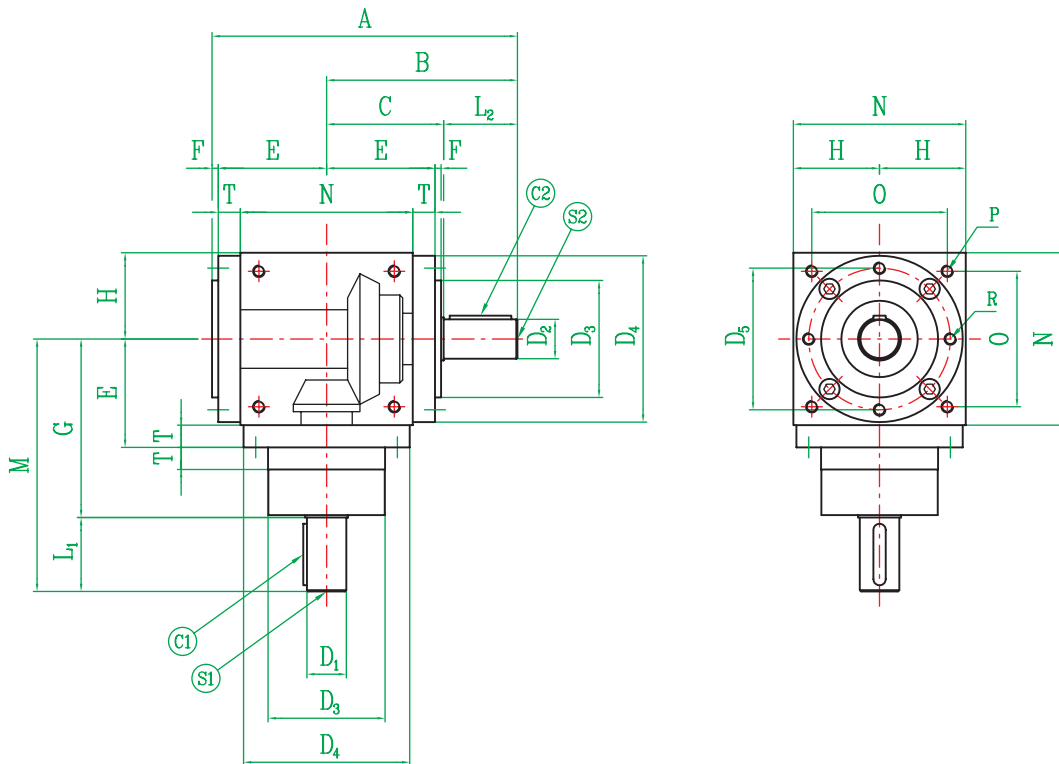

Taglia Size Taille Bautröße	Rapporto Ratio Rapport Übersetzung	A	B	C	D <sub>1</sub>	D <sub>2</sub>	D <sub>3</sub>	D <sub>4</sub>	D <sub>5</sub>	E	F	G	H	L <sub>1</sub>	L <sub>2</sub>
BG12	1, 2, 3	116	72	46	12 j6	12 j6	44 h7	65 **	54	42	2	74	32.5	26	26
BG19	1, 2, 3	168	105	65	19 j6	19 j6	60 h7	86 h7	72	59	4	100	45	40	40
	4, 5				14 j6									30	
BG24	1, 2, 3	208	130	80	24 j6	24 j6	70 h7	105 h7	88	73	5	115	55	50	50
	4, 5				19 j6									40	
BG32	1, 2, 3	248	155	95	32 j6	32 j6	95 h7	135 h7	115	88	5	145	70	60	60
	4, 5				24 j6									50	
BG38	1, 2, 3	288	180	110	38 j6	38 j6	120 h7	165 h7	145	103	5	170	85	70	70
	4, 5				28 j6									60	
BG42	1, 2, 3	328	205	125	42 j6	42 j6	135 h7	190 h7	165	118	5	195	100	80	80
	4, 5				32 j6									60	
BG55	1, 2, 3	408	260	150	55 j6	55 j6	170 h7	230 h7	205	143	5	245	120	110	110
	4, 5				42 j6									80	
BG75	1, 2, 3	598	375	225	75 j6	75 j6	220 *	300 h7 *	--	195	16	350	165	150	150
	4, 5				55 j6		110								

\* Nel caso del rinvio angolare BG75 se occorre centrarsi su questo diametro chiedere informazioni al nostro ufficio tecnico / For spiral bevel gearbox BG75, please request further information to our engineering dept. to be able to centre on this diameter / Dans le cas du renvoi d'angle BG75, s'il faut que le centrage se produise sur ce diamètre, faire appel à notre service d'assistance technique / Sollte es im Falle des Winkel-Vorgeleges BG75 erforderlich sein, sich auf diesen Durchmesser zu zentrieren, sind bei unserer technischen Abteilung Informationen einzuholen.



\*\* Il diametro non è in tolleranza / Diameter is out of tolerance / Le diamètre n'est pas en tolérance / Der Durchmesser ist nicht in Toleranz.

**POSIZIONI DI MONTAGGIO / MOUNTING POSITION**  
**POSITIONS DE MONTAGE / EINBAULAGEN - KEGELRADGETRIEBE**

Schema superiore: Vista dal fianco - Schema inferiore: Vista dall'alto  
 Top diagram: Side view - Bottom diagram: Top view  
 Schéma supérieur: Vu de côté - Schéma inférieur: Vue d'en haut  
 Seitenansicht - Draufsicht

	Sfiato / Breather plug Évent / Einfüll Entlüftungsstopfen
	Livello / Level plug Niveau / Ölstandanzeige
	Scarico / Drain plug Vidange / Ablasschraube

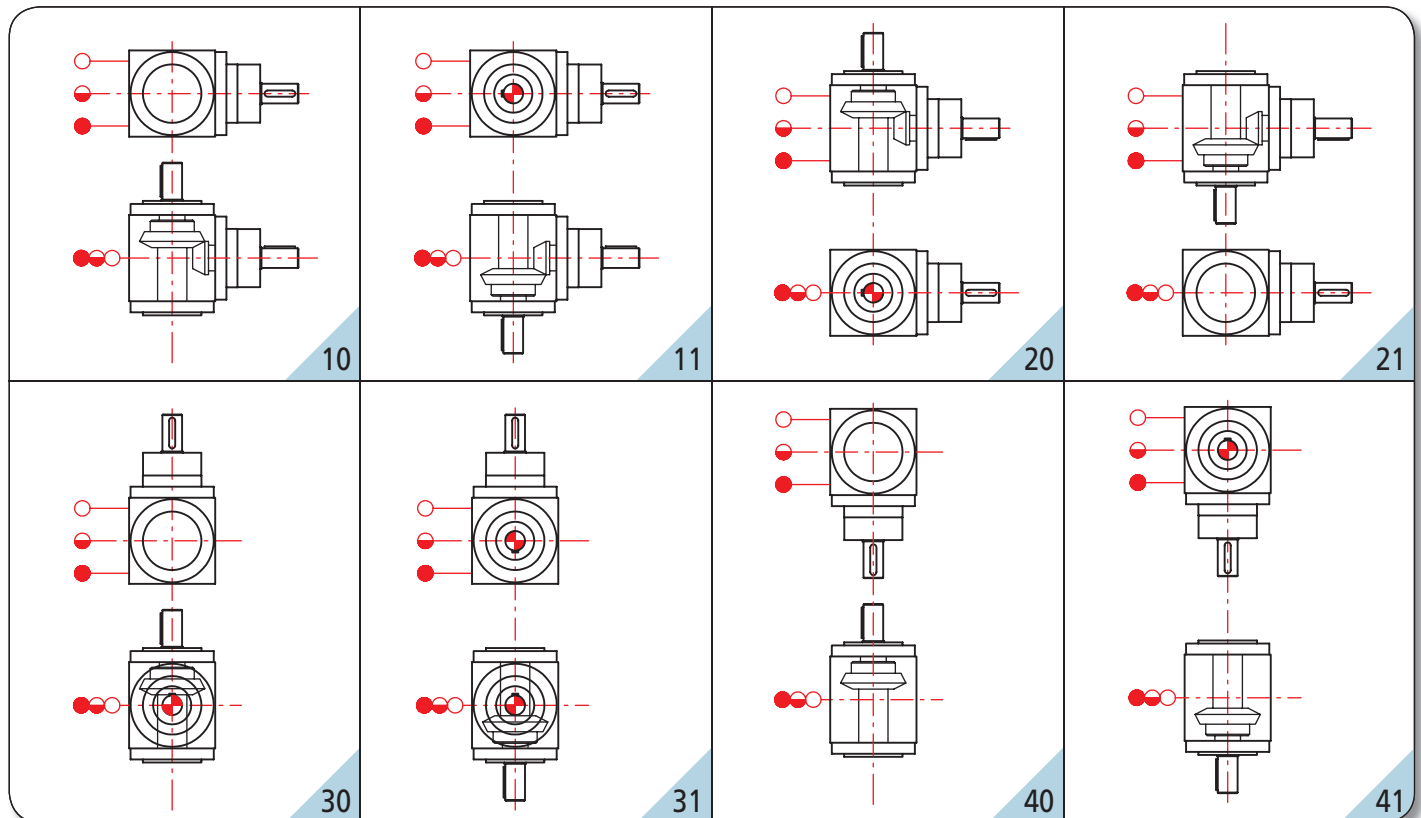

Taglia Size Taille Bautgröße	Rapporto Ratio Rapport Übersetzung	M	N	O	P	R	S1	S2	C1	C2	T
BG12	1, 2, 3	100	65	45	M6 ***	M6	M4x8	M4x8	20x4x4	20x4x4	9.5
BG19	1, 2, 3	140	90	70	M6	M6	M6x12	M6x12	35x6x6	35x6x6	14
	4, 5	130					M5x10		25x5x5		
BG24	1, 2, 3	165	110	88	M8	M8	M8x16	M8x16	40x8x7	40x8x7	18
	4, 5	155					M6x12		35x6x6		
BG32	1, 2, 3	205	140	110	M10	M10	M10x20	M10x20	50x10x8	50x10x8	18
	4, 5	195					M8x16		40x8x7		
BG38	1, 2, 3	240	170	136	M12	M12	M12x24	M12x24	60x10x8	60x10x8	18
	4, 5	230					M10x20		50x8x7		
BG42	1, 2, 3	275	200	155	M12	M12	M12x24	M12x24	70x12x8	70x12x8	18
	4, 5	255					M10x20		50x10x8		
BG55	1, 2, 3	355	240	190	M14	M14	M14x28	M14x28	100x16x10	100x16x10	23
	4, 5	325					M12x24		70x12x8		
BG75	1, 2, 3	500	330	248	M16	M16	M16x32	M16x32	140x20x14	140x20x14	30
	4, 5	460					M14x28		100x16x10		

\*\*\* Nella grandezza BG12 i fori "P" di interasse "O" sono presenti solamente sulle facce libere.  
 On BG12 size the holes P at centres O are only available on the side.  
 Dans la taille BG12 les trous «P» d'entraxe «O» sont présents seulement sur les côtés libres.  
 Bei der Baugröße BG12 sind die Bohrungen P mit dem Lochabstand O nur auf den Seiten ohne Wellen vorhanden.



## DIMENSIONI D'INGOMBRO / DIMENSIONS / DIMENSIONS D'ENCOMBREMENT / MAßE

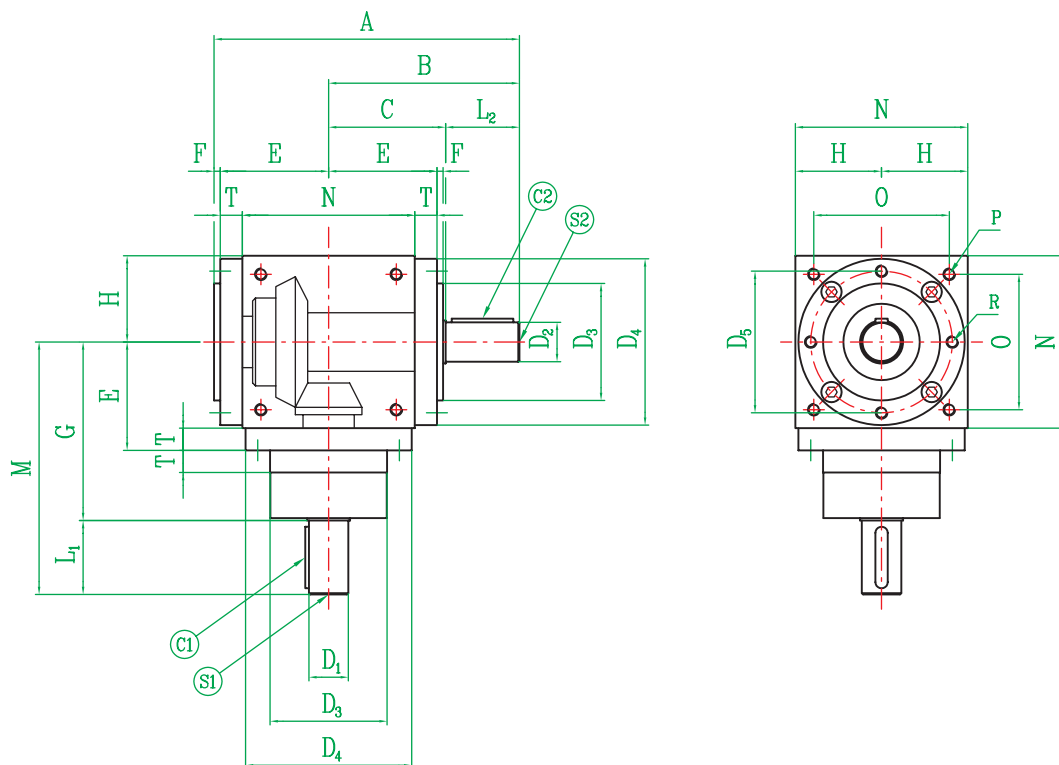

Taglia Size Taille Bautröße	Rapporto Ratio Rapport Übersetzung	A	B	C	D <sub>1</sub>	D <sub>2</sub>	D <sub>3</sub>	D <sub>4</sub>	D <sub>5</sub>	E	F	G	H	L <sub>1</sub>	L <sub>2</sub>
BG12	1, 2, 3	116	72	46	12 j <sub>6</sub>	12 j <sub>6</sub>	44 h <sub>7</sub>	65 **	54	42	2	74	32.5	26	26
BG19	1, 2, 3	168	105	65	19 j <sub>6</sub>	19 j <sub>6</sub>	60 h <sub>7</sub>	86 h <sub>7</sub>	72	59	4	100	45	40	40
	4, 5				14 j <sub>6</sub>									30	
BG24	1, 2, 3	208	130	80	24 j <sub>6</sub>	24 j <sub>6</sub>	70 h <sub>7</sub>	105 h <sub>7</sub>	88	73	5	115	55	50	50
	4, 5				19 j <sub>6</sub>									40	
BG32	1, 2, 3	248	155	95	32 j <sub>6</sub>	32 j <sub>6</sub>	95 h <sub>7</sub>	135 h <sub>7</sub>	115	88	5	145	70	60	60
	4, 5				24 j <sub>6</sub>									50	
BG38	1, 2, 3	288	180	110	38 j <sub>6</sub>	38 j <sub>6</sub>	120 h <sub>7</sub>	165 h <sub>7</sub>	145	103	5	170	85	70	70
	4, 5				28 j <sub>6</sub>									60	
BG42	1, 2, 3	328	205	125	42 j <sub>6</sub>	42 j <sub>6</sub>	135 h <sub>7</sub>	190 h <sub>7</sub>	165	118	5	195	100	80	80
	4, 5				32 j <sub>6</sub>									60	
BG55	1, 2, 3	408	260	150	55 j <sub>6</sub>	55 j <sub>6</sub>	170 h <sub>7</sub>	230 h <sub>7</sub>	205	143	5	245	120	110	110
	4, 5				42 j <sub>6</sub>									80	
BG75	1, 2, 3	598	375	225	75 j <sub>6</sub>	75 j <sub>6</sub>	220 *	300 h <sub>7</sub> *	--	195	16	350	165	150	150
	4, 5				55 j <sub>6</sub>		110								



\* Nel caso del rinvio angolare BG75 se occorre centrarsi su questo diametro chiedere informazioni al nostro ufficio tecnico / For spiral bevel gearbox BG75, please request further information to our engineering dept. to be able to centre on this diameter / Dans le cas du renvoi d'angle BG75, s'il faut que le centrage se produise sur ce diamètre, faire appel à notre service d'assistance technique / Sollte es im Falle des Winkel-Vorgeleges BG75 erforderlich sein, sich auf diesen Durchmesser zu zentrieren, sind bei unserer technischen Abteilung Informationen einzuholen.



\*\* Il diametro non è in tolleranza / Diameter is out of tolerance / Le diamètre n'est pas en tolérance / Der Durchmesser ist nicht in Toleranz.

**POSIZIONI DI MONTAGGIO / MOUNTING POSITION**  
**POSITIONS DE MONTAGE / EINBAULAGEN - KEGELRADGETRIEBE**

Schema superiore: Vista dal fianco - Schema inferiore: Vista dall'alto  
 Top diagram: Side view - Bottom diagram: Top view  
 Schéma supérieur: Vu de côté - Schéma inférieur: Vue d'en haut  
 Seitenansicht - Draufsicht

	Sfiato / Breather plug Évent / Einfüll Entlüftungsstopfen
	Livello / Level plug Niveau / Ölstandanzeige
	Scarico / Drain plug Vidange / Ablasschraube

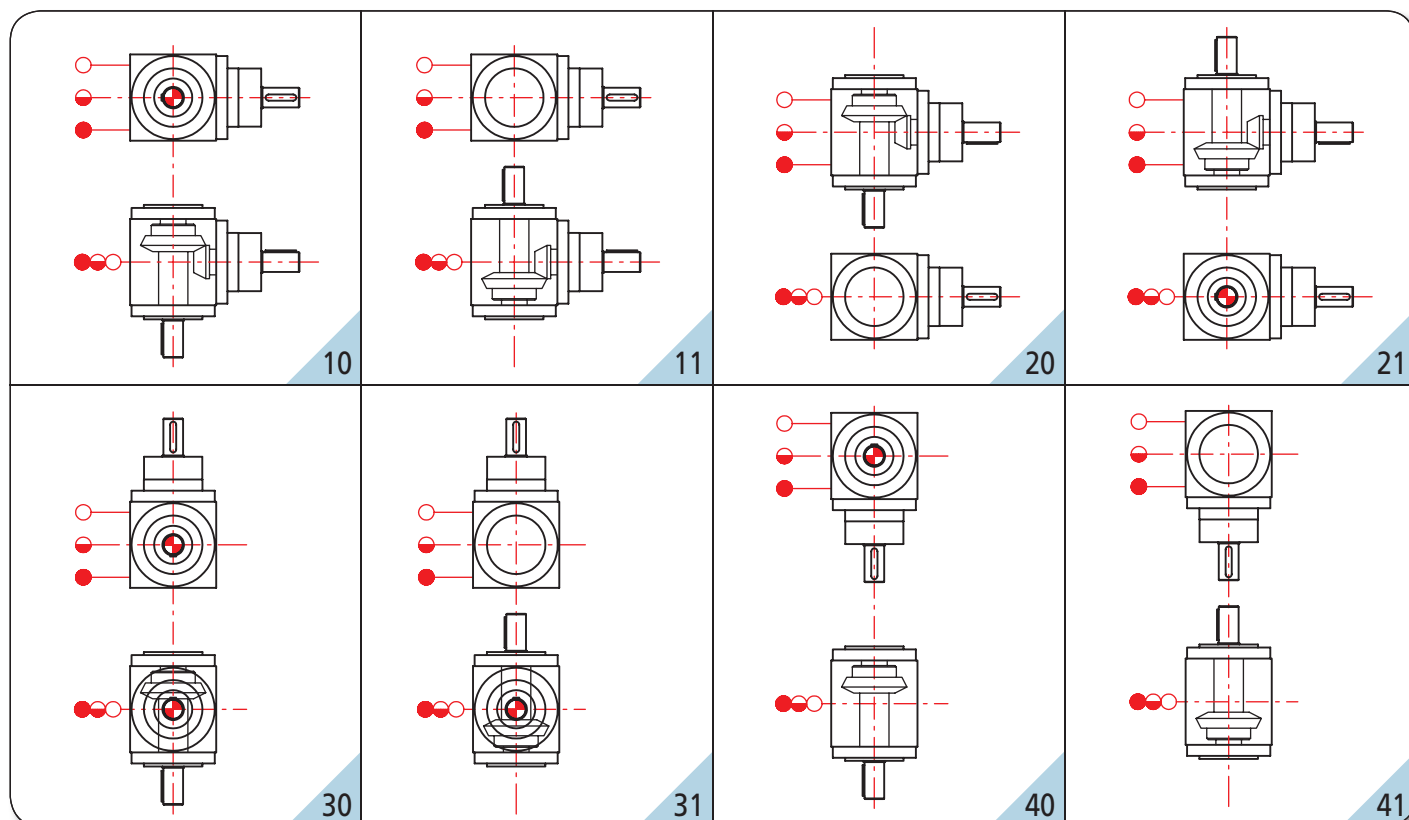

Taglia Size Taille Bautröße	Rapporto Ratio Rapport Übersetzung	M	N	O	P	R	S1	S2	C1	C2	T
BG12	1, 2, 3	100	65	45	M6 ***	M6	M4x8	M4x8	20x4x4	20x4x4	9.5
BG19	1, 2, 3	140	90	70	M6	M6	M6x12	M6x12	35x6x6	35x6x6	14
	4, 5	130					M5x10		25x5x5		
BG24	1, 2, 3	165	110	88	M8	M8	M8x16	M8x16	40x8x7	40x8x7	18
	4, 5	155					M6x12		35x6x6		
BG32	1, 2, 3	205	140	110	M10	M10	M10x20	M10x20	50x10x8	50x10x8	18
	4, 5	195					M8x16		40x8x7		
BG38	1, 2, 3	240	170	136	M12	M12	M12x24	M12x24	60x10x8	60x10x8	18
	4, 5	230					M10x20		50x8x7		
BG42	1, 2, 3	275	200	155	M12	M12	M12x24	M12x24	70x12x8	70x12x8	18
	4, 5	255					M10x20		50x10x8		
BG55	1, 2, 3	355	240	190	M14	M14	M14x28	M14x28	100x16x10	100x16x10	23
	4, 5	325					M12x24		70x12x8		
BG75	1, 2, 3	500	330	248	M16	M16	M16x32	M16x32	140x20x14	140x20x14	30
	4, 5	460					M14x28		100x16x10		

\*\*\* Nella grandezza BG12 i fori "P" di interasse "O" sono presenti solamente sulle facce libere.

On BG12 size the holes P at centres O are only available on the side.

Dans la taille BG12 les trous «P» d'entraxe «O» sont présents seulement sur les côtés libres.

Bei der Baugröße BG12 sind die Bohrungen P mit dem Lochabstand O nur auf den Seiten ohne Wellen vorhanden.



DIMENSIONI D'INGOMBRO / DIMENSIONS / DIMENSIONS D'ENCOMBREMENT / MAßE

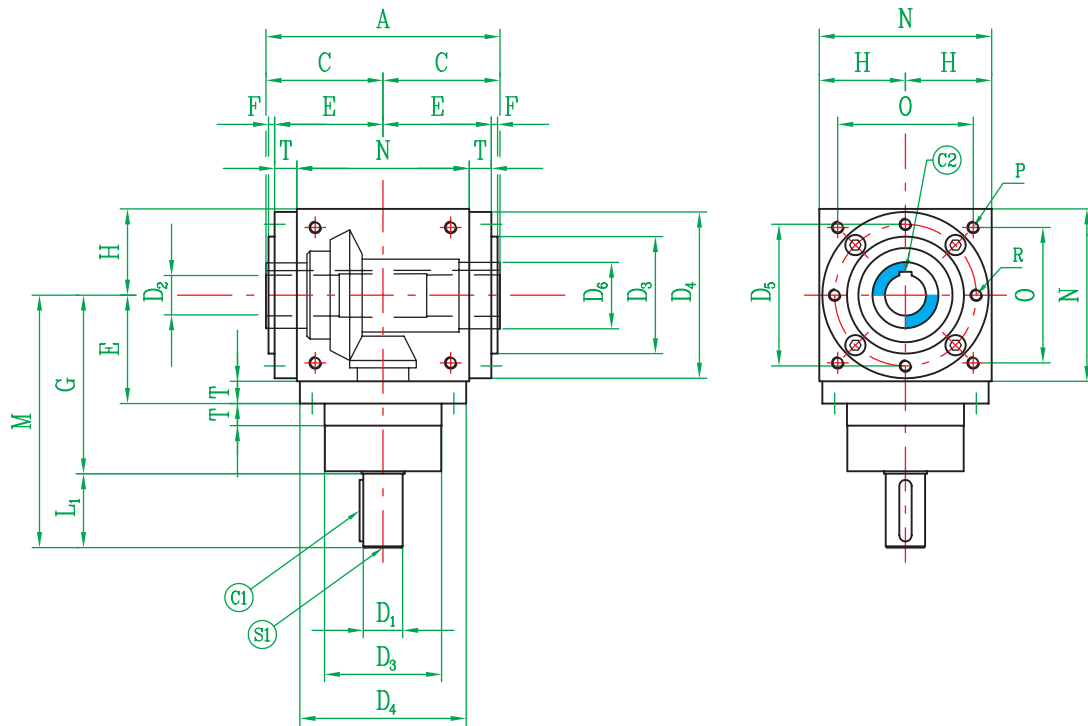

Taglia Size Taille Bautgröße	Rapporto Ratio Rapport Übersetzung	A	C	D <sub>1</sub>	D <sub>2</sub>	D <sub>3</sub>	D <sub>4</sub>	D <sub>5</sub>	D <sub>6</sub>	E	F	G	H	L <sub>1</sub>
BG12	1, 2, 3	92	46	12 j <sub>6</sub>	12 H7	44 h7	65 **	54	20	42	2	74	32.5	26
BG19	1, 2, 3	130	65	19 j <sub>6</sub>	19 H7	60 h7	86 h7	72	30	59	4	100	45	40
	4, 5			14 j <sub>6</sub>										30
BG24	1, 2, 3	160	80	24 j <sub>6</sub>	24 H7	70 h7	105 h7	88	35	73	5	115	55	50
	4, 5			19 j <sub>6</sub>										40
BG32	1, 2, 3	190	95	32 j <sub>6</sub>	32 H7	95 h7	135 h7	115	50	88	5	145	70	60
	4, 5			24 j <sub>6</sub>										50
BG38	1, 2, 3	220	110	38 j <sub>6</sub>	38 H7	120 h7	165 h7	145	60	103	5	170	85	70
	4, 5			28 j <sub>6</sub>										60
BG42	1, 2, 3	250	125	42 j <sub>6</sub>	42 H7	135 h7	190 h7	165	60	118	5	195	100	80
	4, 5			32 j <sub>6</sub>										60
BG55	1, 2, 3	300	150	55 j <sub>6</sub>	55 H7	170 h7	230 h7	205	75	143	5	245	120	110
	4, 5			42 j <sub>6</sub>										80
BG75	1, 2, 3	450	225	75 j <sub>6</sub>	75 H7	220 *	300 h7 *	--	120	195	16	350	165	150
	4, 5			55 j <sub>6</sub>										110



\* Nel caso del rinvio angolare BG75 se occorre centrarsi su questo diametro chiedere informazioni al nostro ufficio tecnico / For spiral bevel gearbox BG75, please request further information to our engineering dept. to be able to centre on this diameter / Dans le cas du renvoi d'angle BG75, s'il faut que le centrage se produise sur ce diamètre, faire appel à notre service d'assistance technique / Sollte es im Falle des Winkel-Vorgeleges BG75 erforderlich sein, sich auf diesen Durchmesser zu zentrieren, sind bei unserer technischen Abteilung Informationen einzuholen.



\*\* Il diametro non è in tolleranza / Diameter is out of tolerance / Le diamètre n'est pas en tolérance / Der Durchmesser ist nicht in Toleranz.

**POSIZIONI DI MONTAGGIO / MOUNTING POSITION**  
**POSITIONS DE MONTAGE / EINBAULAGEN - KEGELRADGETRIEBE**

Schema superiore: Vista dal fianco - Schema inferiore: Vista dall'alto  
 Top diagram: Side view - Bottom diagram: Top view  
 Schéma supérieur: Vu de côté - Schéma inférieur: Vue d'en haut  
 Seitenansicht - Draufsicht

	Sfiato / Breather plug Évent / Einfüll Entlüftungstopfen
	Livello / Level plug Niveau / Ölstandanzeige
	Scarico / Drain plug Vidange / Ablasschraube

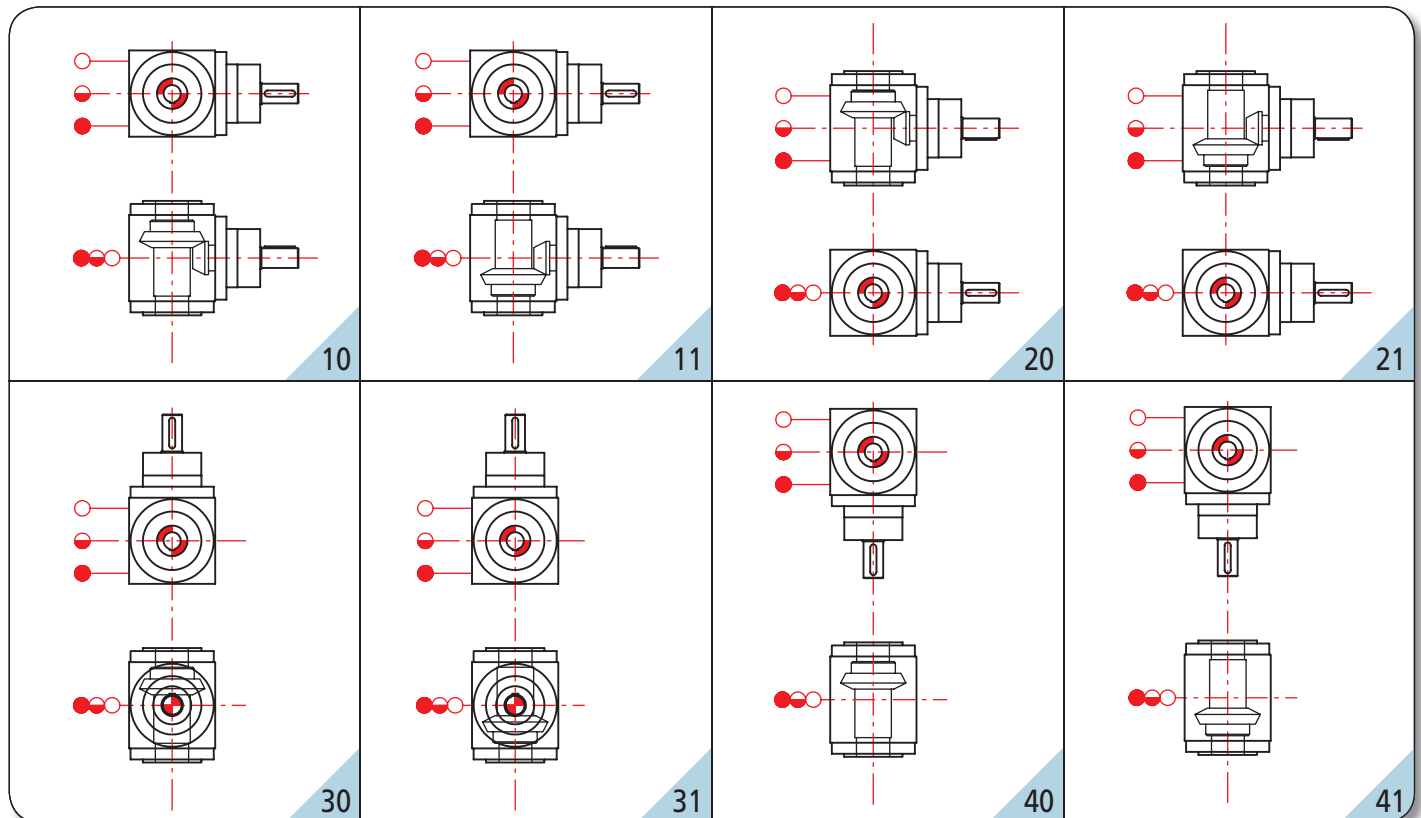

Taglia Size Taille Bautröße	Rapporto Ratio Rapport Übersetzung	M	N	O	P	R	S1	C1	C2	T
BG12	1, 2, 3	100	65	45	M6 ***	M6	M4x8	20x4x4	4x4	9.5
BG19	1, 2, 3	140	90	70	M6	M6	M6x12	35x6x6	6x6	14
	4, 5	130					M5x10	25x5x5		
BG24	1, 2, 3	165	110	88	M8	M8	M8x16	40x8x7	8x7	18
	4, 5	155					M6x12	35x6x6		
BG32	1, 2, 3	205	140	110	M10	M10	M10x20	50x10x8	10x8	18
	4, 5	195					M8x16	40x8x7		
BG38	1, 2, 3	240	170	136	M12	M12	M12x24	60x10x8	10x8	18
	4, 5	230					M10x20	50x8x7		
BG42	1, 2, 3	275	200	155	M12	M12	M12x24	70x12x8	12x8	18
	4, 5	255					M10x20	50x10x8		
BG55	1, 2, 3	355	240	190	M14	M14	M14x28	100x16x10	16x10	23
	4, 5	325					M12x24	70x12x8		
BG75	1, 2, 3	500	330	248	M16	M16	M16x32	140x20x14	20x14	30
	4, 5	460					M14x28	100x16x10		

\*\*\* Nella grandezza BG12 i fori "P" di interasse "O" sono presenti solamente sulle facce libere.  
 On BG12 size the holes P at centres O are only available on the side.  
 Dans la taille BG12 les trous «P» d'entraxe «O» sont présents seulement sur les côtés libres.  
 Bei der Baugröße BG12 sind die Bohrungen P mit dem Lochabstand O nur auf den Seiten ohne Wellen vorhanden.



DIMENSIONI D'INGOMBRO / DIMENSIONS / DIMENSIONS D'ENCOMBREMENT / MAßE

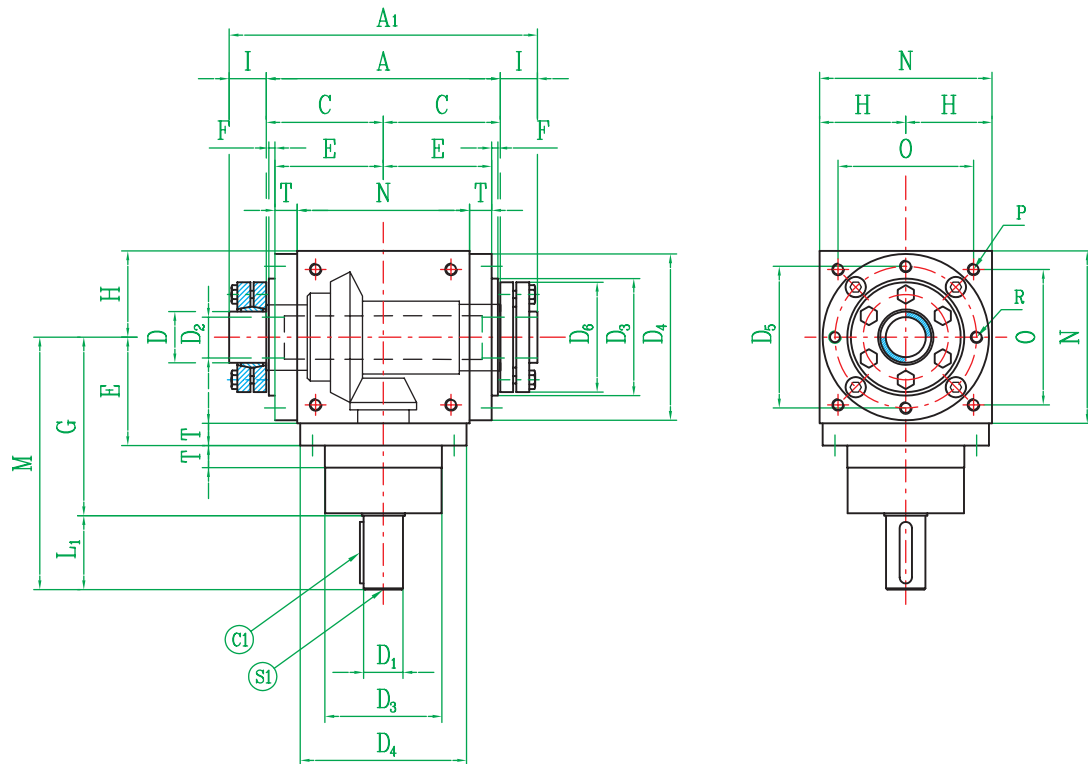

Taglia Size Taille Bautröße	Rapporto Ratio Rapport Übersetzung	A	A <sub>1</sub>	C	D	D <sub>1</sub>	D <sub>2</sub>	D <sub>3</sub>	D <sub>4</sub>	D <sub>5</sub>	D <sub>6</sub>	E	F	G
BG12	1, 2, 3	92	121	46	14 h7	12 j6	12 H7	44 h7	65 **	54	38	42	2	74
BG19	1, 2, 3	130	178	65	24 h7	19 j6	19 H7	60 h7	86 h7	72	50	59	4	100
	4, 5					14 j6								
BG24	1, 2, 3	160	212	80	30 h7	24 j6	24 H7	70 h7	105 h7	88	60	73	5	115
	4, 5					19 j6								
BG32	1, 2, 3	190	250	95	44 h7	32 j6	32 H7	95 h7	135 h7	115	80	88	5	145
	4, 5					24 j6								
BG38	1, 2, 3	220	284	110	50 h7	38 j6	38 H7	120 h7	165 h7	145	90	103	5	170
	4, 5					28 j6								
BG42	1, 2, 3	250	320	125	55 h7	42 j6	42 H7	135 h7	190 h7	165	100	118	5	195
	4, 5					32 j6								
BG55	1, 2, 3	300	370	150	68 h7	55 j6	55 H7	170 h7	230 h7	205	115	143	5	245
	4, 5					42 j6								
BG75	1, 2, 3	450	544	225	90 h7	75 j6	75 H7	220 *	300 h7 *	--	155	195	16	350
	4, 5					55 j6								

\* Nel caso del rinvio angolare BG75 se occorre centrarsi su questo diametro chiedere informazioni al nostro ufficio tecnico / For spiral bevel gearbox BG75, please request further information to our engineering dept. to be able to centre on this diameter / Dans le cas du renvoi d'angle BG75, s'il faut que le centrage se produise sur ce diamètre, faire appel à notre service d'assistance technique / Sollte es im Falle des Winkel-Vorgeleges BG75 erforderlich sein, sich auf diesen Durchmesser zu zentrieren, sind bei unserer technischen Abteilung Informationen einzuholen.



\*\* Il diametro non è in tolleranza / Diameter is out of tolerance / Le diamètre n'est pas en tolérance / Der Durchmesser ist nicht in Toleranz.



**POSIZIONI DI MONTAGGIO / MOUNTING POSITION**  
**POSITIONS DE MONTAGE / EINBAULAGEN - KEGELRADGETRIEBE**

Schema superiore: Vista dal fianco - Schema inferiore: Vista dall'alto  
 Top diagram: Side view - Bottom diagram: Top view  
 Schéma supérieur: Vu de côté - Schéma inférieur: Vue d'en haut  
 Seitenansicht - Draufsicht

	Sfiato / Breather plug Évent / Einfüll Entlüftungsstopfen
	Livello / Level plug Niveau / Ölstandanzeige
	Scarico / Drain plug Vidange / Ablassschraube

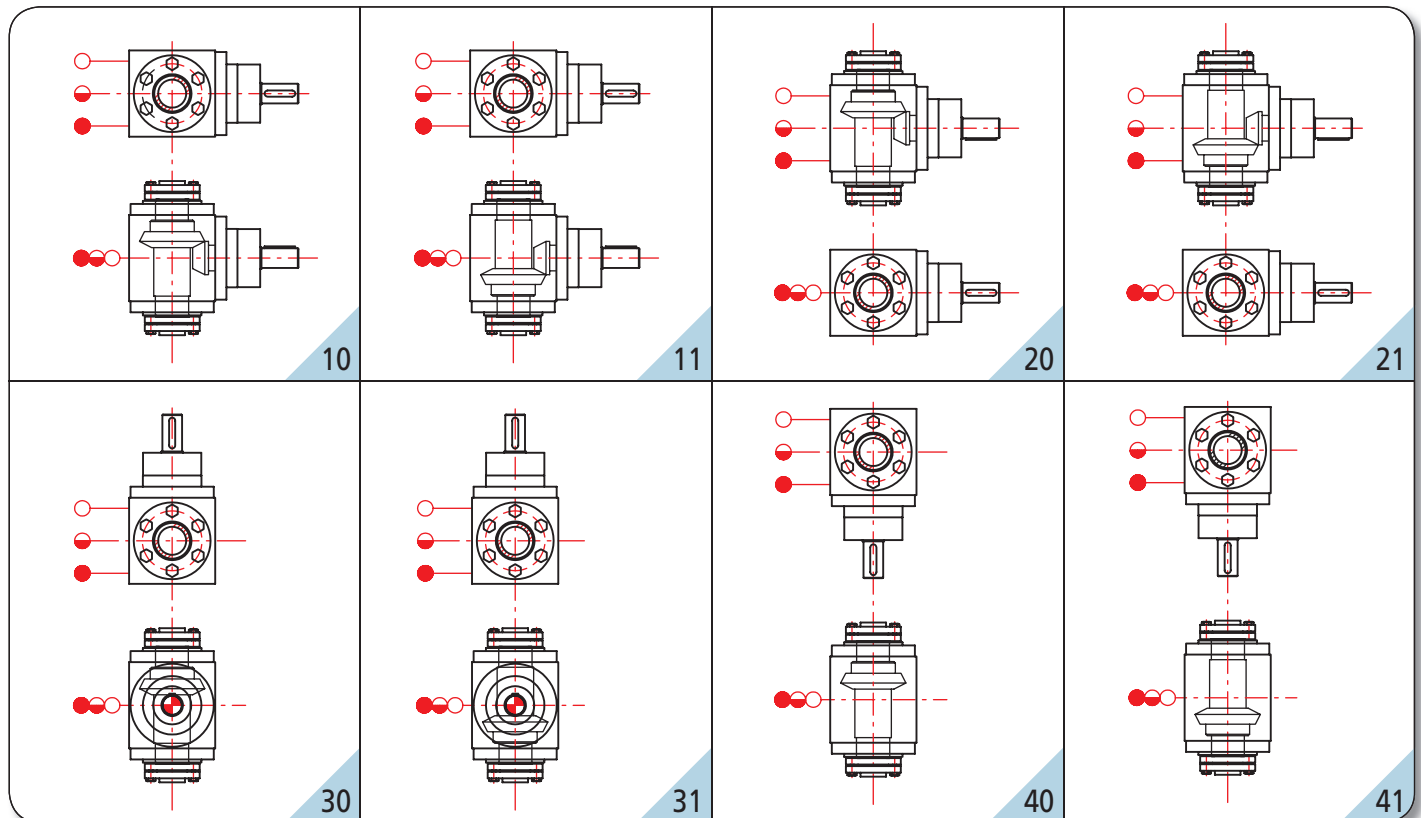

Taglia Size Taille Bautröße	Rapporto Ratio Rapport Übersetzung	H	I	M	L <sub>1</sub>	N	O	P	R	S1	C1	T
BG12	1, 2, 3	32.5	15	100	26	65	45	M6 ***	M6	M4x8	20x4x4	9.5
BG19	1, 2, 3	45	24	140	40	90	70	M6	M6	M6x12	35x6x6	14
	4, 5			130	30					M5x10	25x5x5	
BG24	1, 2, 3	55	26	165	50	110	88	M8	M8	M8x16	40x8x7	18
	4, 5			155	40					M6x12	35x6x6	
BG32	1, 2, 3	70	30	205	60	140	110	M10	M10	M10x20	50x10x8	18
	4, 5			195	50					M8x16	40x8x7	
BG38	1, 2, 3	85	32	240	70	170	136	M12	M12	M12x24	60x10x8	18
	4, 5			230	60					M10x20	50x8x7	
BG42	1, 2, 3	100	35	275	80	200	155	M12	M12	M12x24	70x12x8	18
	4, 5			255	60					M10x20	50x10x8	
BG55	1, 2, 3	120	35	355	110	240	190	M14	M14	M14x28	100x16x10	23
	4, 5			325	80					M12x24	70x12x8	
BG75	1, 2, 3	165	47	500	150	330	248	M16	M16	M16x32	140x20x14	30
	4, 5			460	110					M14x28	100x16x10	

\*\*\* Nella grandezza BG12 i fori "P" di interasse "O" sono presenti solamente sulle facce libere.  
 On BG12 size the holes P at centres O are only available on the side.  
 Dans la taille BG12 les trous «P» d'entraxe «O» sont présents seulement sur les côtés libres.  
 Bei der Baugröße BG12 sind die Bohrungen P mit dem Lochabstand O nur auf den Seiten ohne Wellen vorhanden.



DIMENSIONI D'INGOMBRO / DIMENSIONS / DIMENSIONS D'ENCOMBREMENT / MAßE

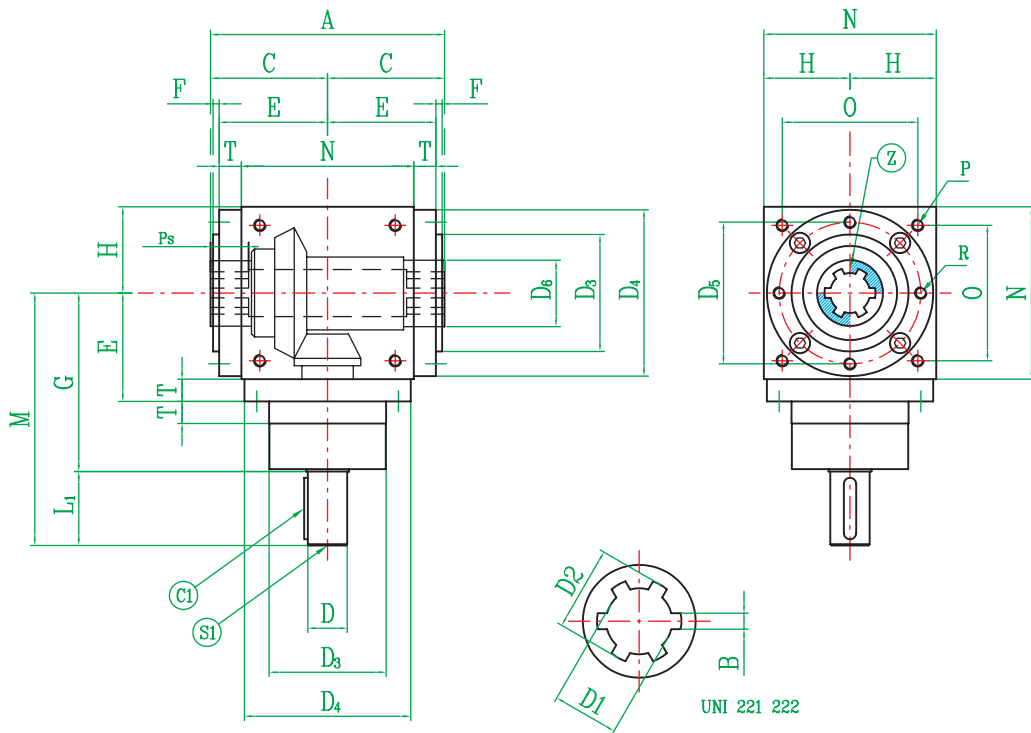

Taglia Size Taille Bautröße	Rapporto Ratio Rapport Übersetzung	A	C	D	Ps	D <sub>1</sub>	D <sub>2</sub>	B	D <sub>3</sub>	D <sub>4</sub>	D <sub>5</sub>	D <sub>6</sub>	E	F	G
BG12	1, 2, 3	92	46	12 j6	13	11	14	3	44 h7	65 **	54	20	42	2	74
BG19	1, 2, 3	130	65	19 j6	15	13	16	3.5	60 h7	86 h7	72	30	59	4	100
	4, 5			14 j6											
BG24	1, 2, 3	160	80	24 j6	20	18	22	5	70 h7	105 h7	88	35	73	5	115
	4, 5			19 j6											
BG32	1, 2, 3	190	95	32 j6	25	21	25	5	95 h7	135 h7	115	50	88	5	145
	4, 5			24 j6											
BG38	1, 2, 3	220	110	38 j6	30	28	34	7	120 h7	165 h7	145	60	103	5	170
	4, 5			28 j6											
BG42	1, 2, 3	250	125	42 j6	35	36	42	7	135 h7	190 h7	165	60	118	5	195
	4, 5			32 j6											
BG55	1, 2, 3	300	150	55 j6	40	46	54	8	170 h7	230 h7	205	75	143	5	245
	4, 5			42 j6											
BG75	1, 2, 3	450	225	75 j6	50	72	82	12	220 *	300 h7 *	--	120	195	16	350
	4, 5			55 j6											

\* Nel caso del rinvio angolare BG75 se occorre centrarsi su questo diametro chiedere informazioni al nostro ufficio tecnico / For spiral bevel gearbox BG75, please request further information to our engineering dept. to be able to centre on this diameter / Dans le cas du renvoi d'angle BG75, s'il faut que le centrage se produise sur ce diamètre, faire appel à notre service d'assistance technique / Sollte es im Falle des Winkel-Vorgeleges BG75 erforderlich sein, sich auf diesen Durchmesser zu zentrieren, sind bei unserer technischen Abteilung Informationen einzuholen.



\*\* Il diametro non è in tolleranza / Diameter is out of tolerance / Le diamètre n'est pas en tolérance / Der Durchmesser ist nicht in Toleranz.

**POSIZIONI DI MONTAGGIO / MOUNTING POSITION**  
**POSITIONS DE MONTAGE / EINBAULAGEN - KEGELRADGETRIEBE**

Schema superiore: Vista dal fianco - Schema inferiore: Vista dall'alto  
 Top diagram: Side view - Bottom diagram: Top view  
 Schéma supérieur: Vu de côté - Schéma inférieur: Vue d'en haut  
 Seitenansicht - Draufsicht

	Sfiato / Breather plug Évent / Einfüll Entlüftungsstopfen
	Livello / Level plug Niveau / Ölstandanzeige
	Scarico / Drain plug Vidange / Ablasschraube

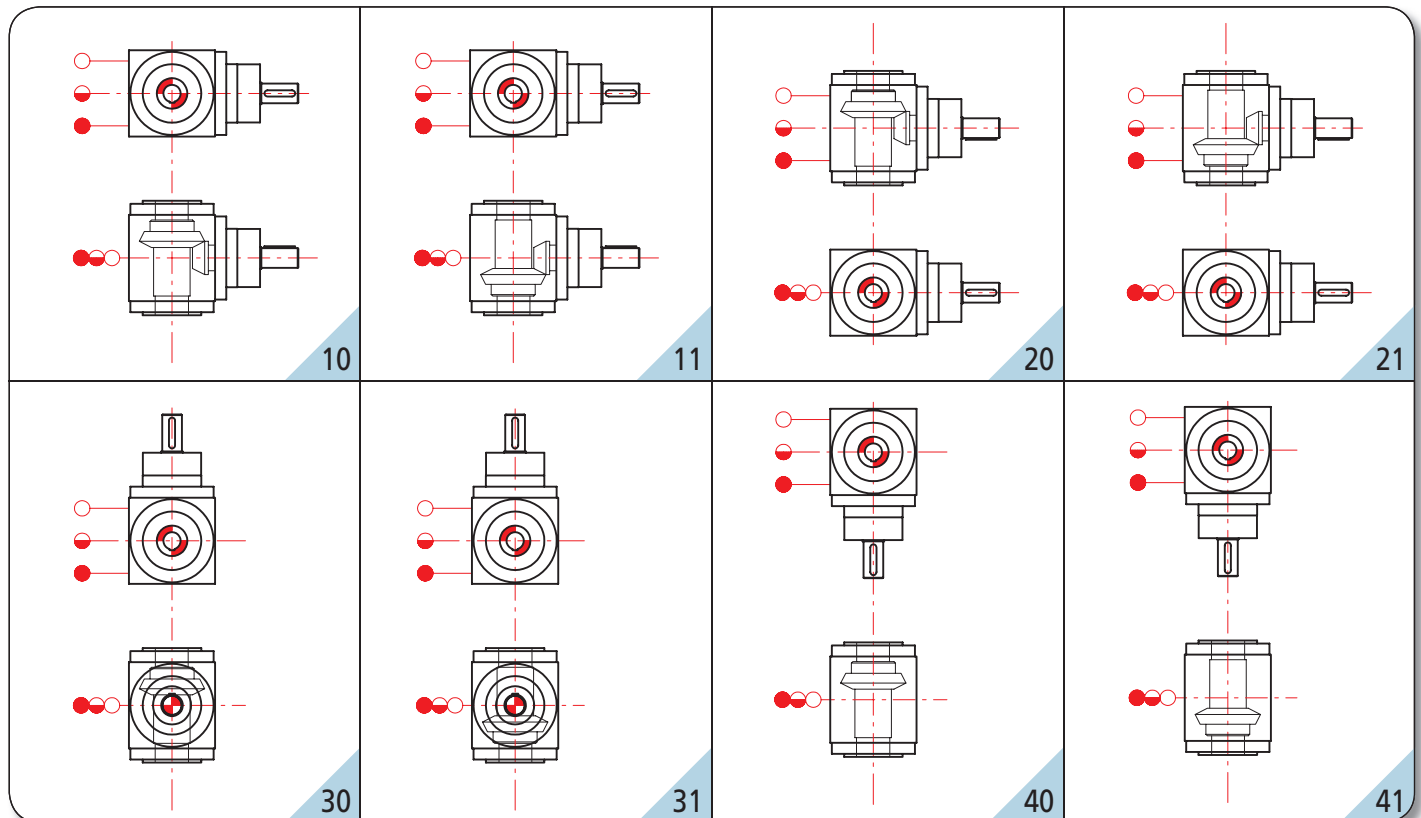

31

Taglia Size Taille Bautgröße	Rapporto Ratio Rapport Übersetzung	H	L <sub>1</sub>	M	N	O	P	R	S1	C1	Z	T
BG12	1, 2, 3	32.5	26	100	65	45	M6 ***	M6	M4x8	20x4x4	6	9.5
BG19	1, 2, 3	45	40	140	90	70	M6	M6	M6x12	35x6x6	6	14
	4, 5		30	130					M5x10	25x5x5		
BG24	1, 2, 3	55	50	165	110	88	M8	M8	M8x16	40x8x7	6	18
	4, 5		40	155					M6x12	35x6x6		
BG32	1, 2, 3	70	60	205	140	110	M10	M10	M10x20	50x10x8	6	18
	4, 5		50	195					M8x16	40x8x7		
BG38	1, 2, 3	85	70	240	170	136	M12	M12	M12x24	60x10x8	6	18
	4, 5		60	230					M10x20	50x8x7		
BG42	1, 2, 3	100	80	275	200	155	M12	M12	M12x24	70x12x8	8	18
	4, 5		60	255					M10x20	50x10x8		
BG55	1, 2, 3	120	110	355	240	190	M14	M14	M14x28	100x16x10	8	23
	4, 5		80	325					M12x24	70x12x8		
BG75	1, 2, 3	165	150	500	330	248	M16	M16	M16x32	140x20x14	10	30
	4, 5		110	460					M14x28	100x16x10		

\*\*\* Nella grandezza BG12 i fori "P" di interasse "O" sono presenti solamente sulle facce libere.

On BG12 size the holes P at centres O are only available on the side.

Dans la taille BG12 les trous «P» d'entraxe «O» sont présents seulement sur les côtés libres.

Bei der Baugröße BG12 sind die Bohrungen P mit dem Lochabstand O nur auf den Seiten ohne Wellen vorhanden.



DIMENSIONI D'INGOMBRO / DIMENSIONS / DIMENSIONS D'ENCOMBREMENT / MAßE

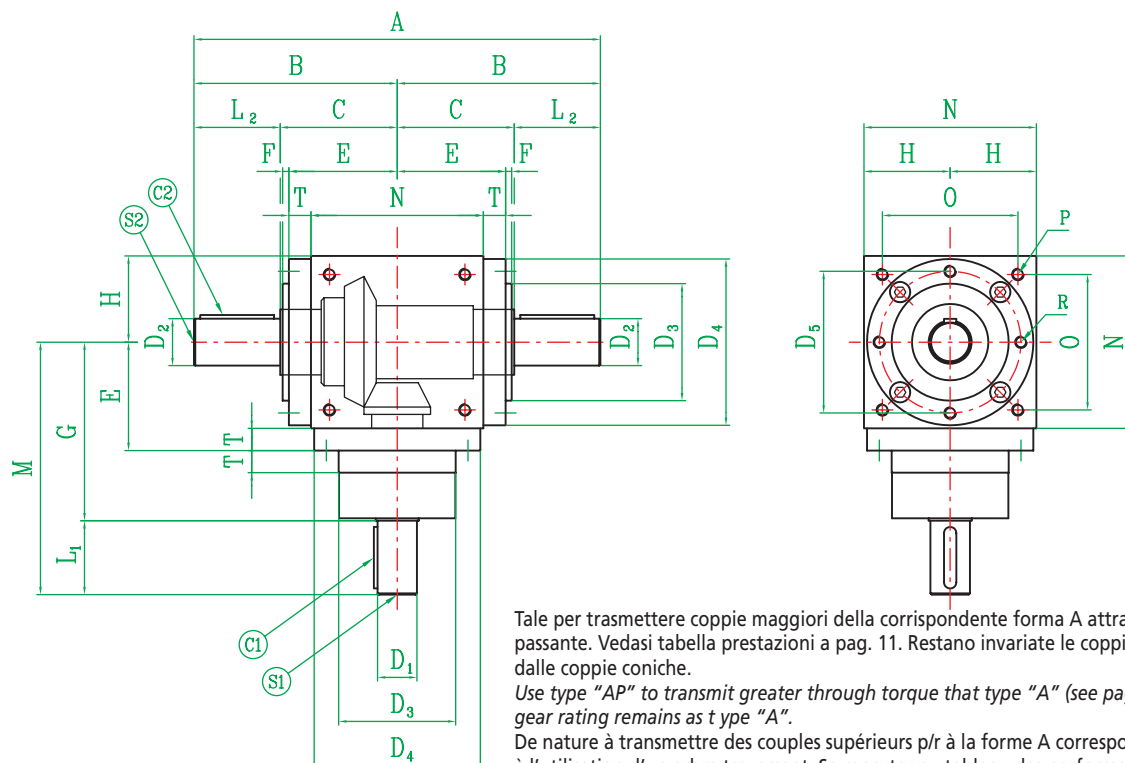

Tale per trasmettere coppie maggiori della corrispondente forma A attraverso l'albero passante. Vedasi tabella prestazioni a pag. 11. Restano invariate le coppie trasmissibili dalle coppie coniche.

Use type "AP" to transmit greater through torque that type "A" (see page 11). The gear rating remains as type "A".

De nature à transmettre des couples supérieurs p/r à la forme A correspondante, grâce à l'utilisation d'un arbre traversant. Se reporter au tableau des performances à page 11. Les couples transmis par les engrenages coniques demeurent inchangés.

Die form AP überträgt größere Drehmomente als FORM A (siehe Tabelle Leistungsangaben Seite 11). Die Momente der Kegelräder bleiben unverändert.

Taglia Size Taille Bautgröße	Rapporto Ratio Rapport Übersetzung	A	B	C	D <sub>1</sub>	D <sub>2</sub>	D <sub>3</sub>	D <sub>4</sub>	D <sub>5</sub>	E	F	G	H	L <sub>1</sub>	L <sub>2</sub>
BG12	1, 2, 3	116	72	46	12 j6	19 j6	44 h7	65 **	54	42	2	74	32.5	26	26
BG19	1, 2, 3	230	115	65	19 j6	24 j6	60 h7	86 h7	72	59	4	100	45	40	50
	4, 5				14 j6									30	
BG24	1, 2, 3	280	140	80	24 j6	32 j6	70 h7	105 h7	88	73	5	115	55	50	60
	4, 5				19 j6									40	
BG32	1, 2, 3	330	165	95	32 j6	38 j6	95 h7	135 h7	115	88	5	145	70	60	70
	4, 5				24 j6									50	
BG38	1, 2, 3	380	190	110	38 j6	42 j6	120 h7	165 h7	145	103	5	170	85	70	80
	4, 5				28 j6									60	
BG42	1, 2, 3	430	215	125	42 j6	48 j6	135 h7	190 h7	165	118	5	195	100	80	90
	4, 5				32 j6									60	
BG55	1, 2, 3	520	260	150	55 j6	70 j6	170 h7	230 h7	205	143	5	245	120	110	110
	4, 5				42 j6									80	
BG75	1, 2, 3	750	375	225	75 j6	90 j6	220 *	300 h7 *	--	195	16	350	165	150	150
	4, 5				55 j6									110	

\* Nel caso del rinvio angolare BG75 se occorre centrarsi su questo diametro chiedere informazioni al nostro ufficio tecnico / For spiral bevel gearbox BG75, please request further information to our engineering dept. to be able to centre on this diameter / Dans le cas du renvoi d'angle BG75, s'il faut que le centrage se produise sur ce diamètre, faire appel à notre service d'assistance technique / Sollte es im Falle des Winkel-Vorgeleges BG75 erforderlich sein, sich auf diesen Durchmesser zu zentrieren, sind bei unserer technischen Abteilung Informationen einzuholen.



\*\* Il diametro non è in tolleranza / Diameter is out of tolerance / Le diamètre n'est pas en tolérance / Der Durchmesser ist nicht in Toleranz.

**POSIZIONI DI MONTAGGIO / MOUNTING POSITION**  
**POSITIONS DE MONTAGE / EINBAULAGEN - KEGELRADGETRIEBE**

Schema superiore: Vista dal fianco - Schema inferiore: Vista dall'alto  
 Top diagram: Side view - Bottom diagram: Top view  
 Schéma supérieur: Vu de côté - Schéma inférieur: Vue d'en haut  
 Seitenansicht - Draufsicht

	Sfiato / Breather plug Évent / Einfüll Entlüftungstopfen
	Livello / Level plug Niveau / Ölstandanzeige
	Scarico / Drain plug Vidange / Ablasschraube

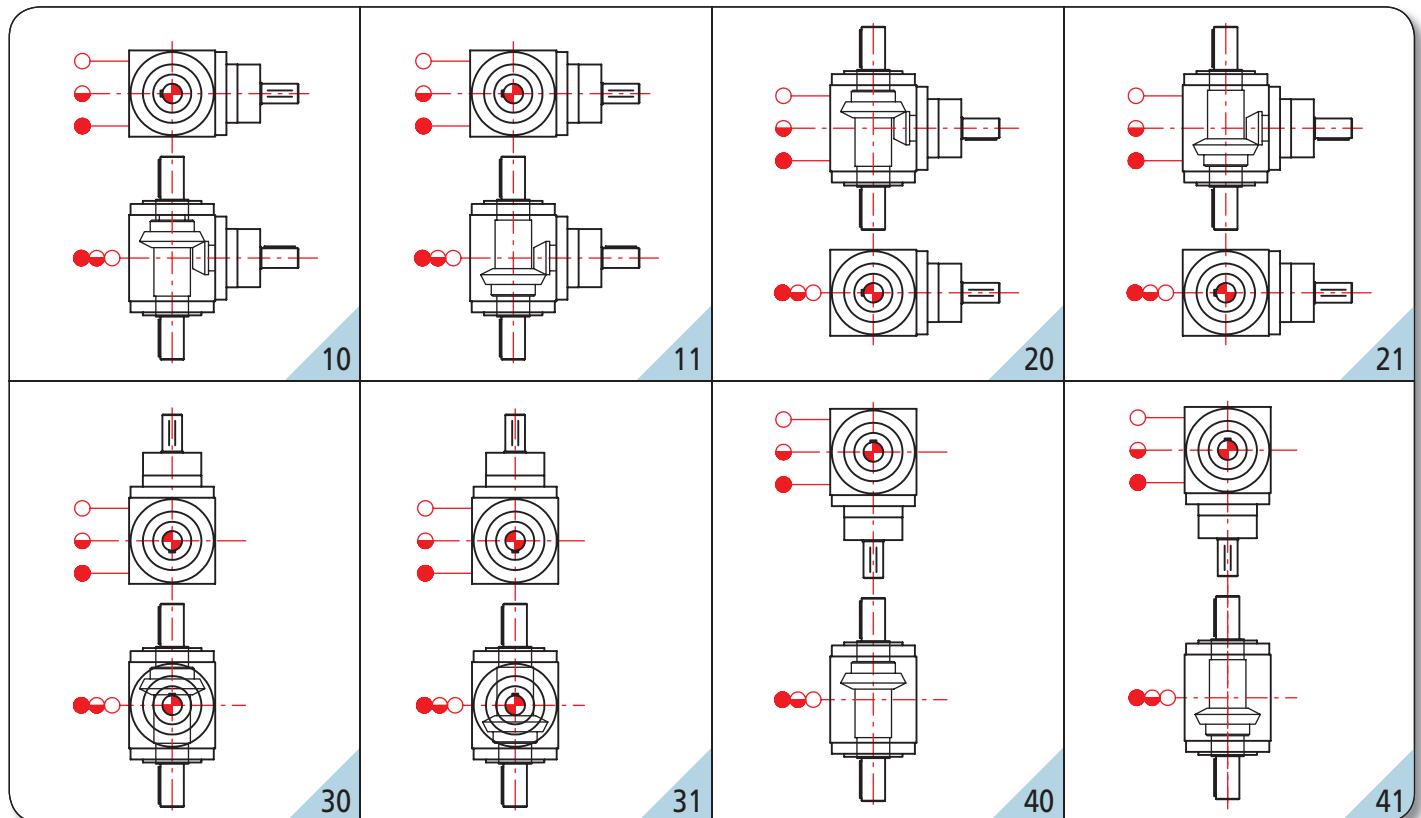

Taglia Size Taille Bautröße	Rapporto Ratio Rapport Übersetzung	M	N	O	P	R	S1	S2	C1	C2	T
BG12	1, 2, 3	100	65	45	M6 ***	M6	M4x8	M4x8	20x4x4	20x4x4	9.5
BG19	1, 2, 3	140	90	70	M6	M6	M6x12	M8x16	35x6x6	40x8x7	14
	4, 5	130					M5x10		25x5x5		
BG24	1, 2, 3	165	110	88	M8	M8	M8x16	M10x20	40x8x7	50x10x8	18
	4, 5	155					M6x12		35x6x6		
BG32	1, 2, 3	205	140	110	M10	M10	M10x20	M12x24	50x10x8	60x10x8	18
	4, 5	195					M8x16		40x8x7		
BG38	1, 2, 3	240	170	136	M12	M12	M12x24	M12x24	60x10x8	70x12x8	18
	4, 5	230					M10x20		50x8x7		
BG42	1, 2, 3	275	200	155	M12	M12	M12x24	M14x28	70x12x8	80x14x9	18
	4, 5	255					M10x20		50x10x8		
BG55	1, 2, 3	355	240	190	M14	M14	M14x28	M14x28	100x16x10	100x20x14	23
	4, 5	325					M12x24		70x12x8		
BG75	1, 2, 3	500	330	248	M16	M16	M16x32	M16x32	140x20x14	140x25x14	30
	4, 5	460					M14x28		100x16x10		

\*\*\* Nella grandezza BG12 i fori "P" di interasse "O" sono presenti solamente sulle facce libere.  
 On BG12 size the holes P at centres O are only available on the side.  
 Dans la taille BG12 les trous «P» d'entraxe «O» sont présents seulement sur les côtés libres.  
 Bei der Baugröße BG12 sind die Bohrungen P mit dem Lochabstand O nur auf den Seiten ohne Wellen vorhanden.



DIMENSIONI D'INGOMBRO / DIMENSIONS / DIMENSIONS D'ENCOMBREMENT / MAßE

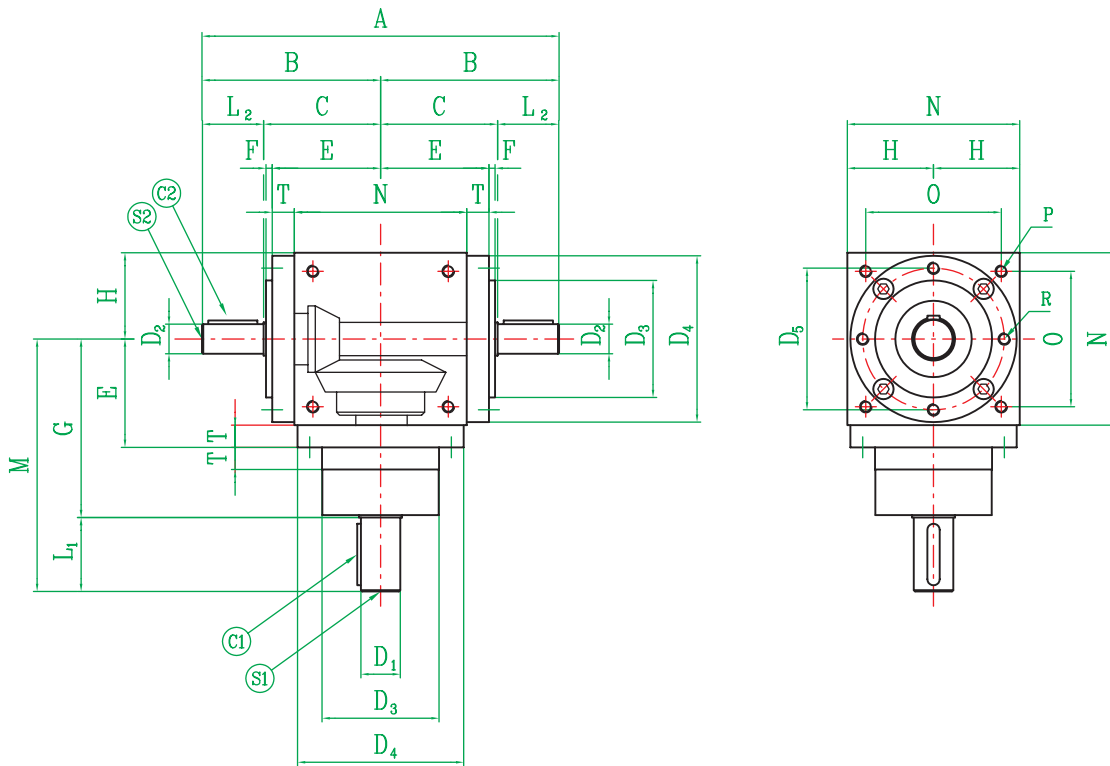



Taglia Size Taille Bautröße	Rapporto Ratio Rapport Übersetzung	A	B	C	D <sub>1</sub>	D <sub>2</sub>	D <sub>3</sub>	D <sub>4</sub>	D <sub>5</sub>	E	F	G	H	L <sub>1</sub>	L <sub>2</sub>
BG19	1.5, 2	190	95	65	19 j6	14 j6	60 h7	86 h7	72	59	4	100	45	40	30
BG24	1.5, 2	240	120	80	24 j6	19 j6	70 h7	105 h7	88	73	5	115	55	50	40
BG32	1.5	290	145	95	32 j6	24 j6	95 h7	135 h7	115	88	5	145	70	60	50
	2	270	135		19 j6	40									
BG38	1.5, 2	340	170	110	38 j6	28 j6	120 h7	165 h7	145	103	5	170	85	70	60
BG42	1.5	390	195	125	42 j6	38 j6	135 h7	190 h7	165	118	5	195	100	80	70
	2	370	185		32 j6	60									
BG55	1.5	460	230	150	55 j6	42 j6	170 h7	230 h7	205	143	5	245	120	110	80
	2	440	220		38 j6	70									
BG75	1.5, 2	670	335	225	75 j6	55 j6	220 *	300 h7 *	--	195	16	350	165	150	110

\* Nel caso del rinvio angolare BG75 se occorre centrarsi su questo diametro chiedere informazioni al nostro ufficio tecnico / For spiral bevel gearbox BG75, please request further information to our engineering dept. to be able to centre on this diameter / Dans le cas du renvoi d'angle BG75, s'il faut que le centrage se produise sur ce diamètre, faire appel à notre service d'assistance technique / Sollte es im Falle des Winkel-Vorgeleges BG75 erforderlich sein, sich auf diesen Durchmesser zu zentrieren, sind bei unserer technischen Abteilung Informationen einzuholen.



**POSIZIONI DI MONTAGGIO / MOUNTING POSITION**  
**POSITIONS DE MONTAGE / EINBAULAGEN - KEGELRADGETRIEBE**

Schema superiore: Vista dal fianco - Schema inferiore: Vista dall'alto  
 Top diagram: Side view - Bottom diagram: Top view  
 Schéma supérieur: Vu de côté - Schéma inférieur: Vue d'en haut  
 Seitenansicht - Draufsicht

	Sfiato / Breather plug Évent / Einfüll Entlüftungsstopfen
	Livello / Level plug Niveau / Ölstandanzeige
	Scarico / Drain plug Vidange / Ablaßschraube

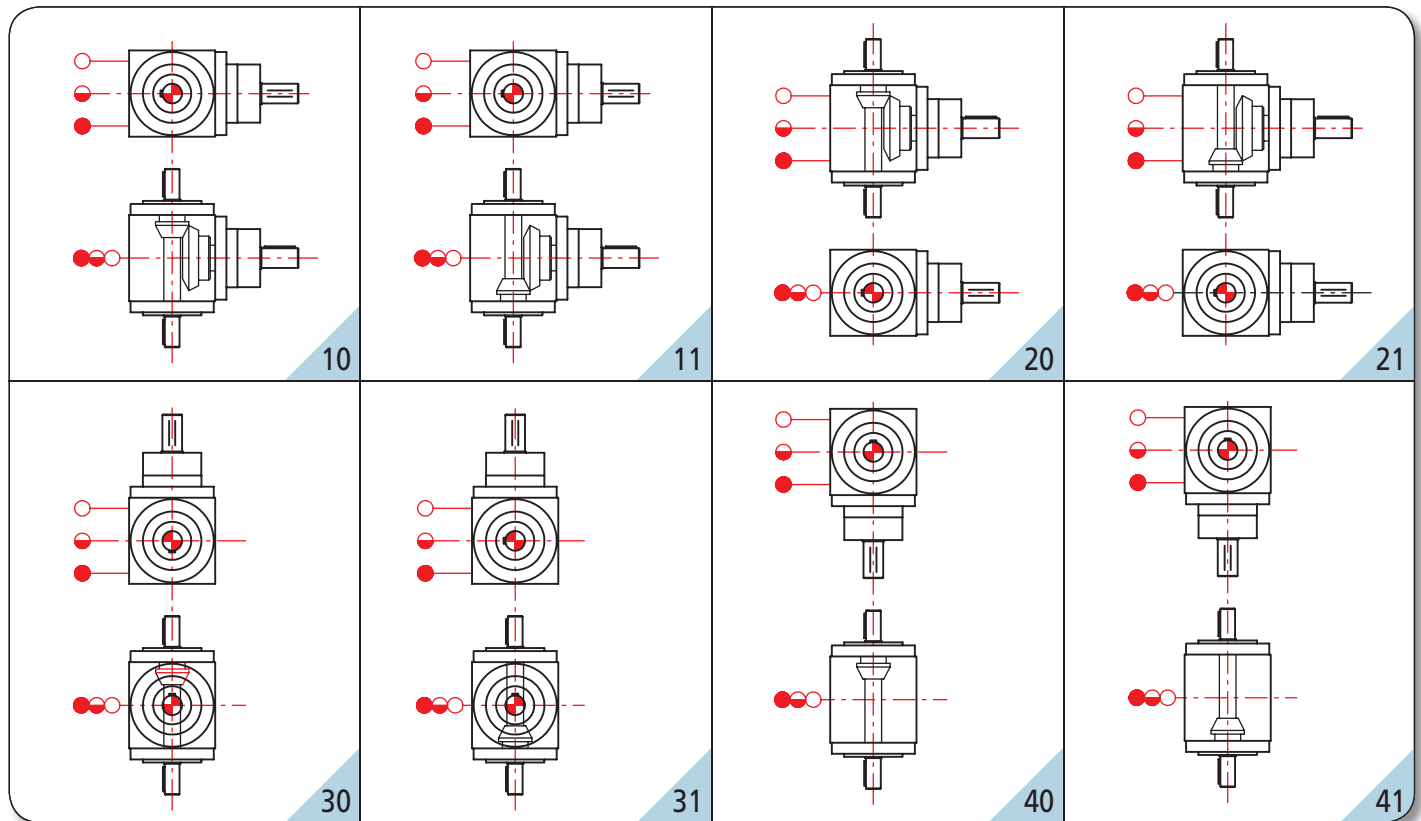

Taglia Size Taille Bautröße	Rapporto Ratio Rapport Übersetzung	M	N	O	P	R	S1	S2	C1	C2	T
BG19	1.5, 2	140	90	70	M6	M6	M6x12	M5x10	35x6x6	25x5x5	14
BG24	1.5, 2	165	110	88	M8	M8	M8x16	M6x12	40x8x7	35x6x6	18
BG32	1.5	205	140	110	M10	M10	M10x20	M8x16	50x10x8	40x8x7	18
	2							M6x12		35x6x6	
BG38	1.5, 2	240	170	136	M12	M12	M12x24	M10x20	60x10x8	50x8x7	18
BG42	1.5	275	200	155	M12	M12	M12x24	M12x24	70x12x8	60x10x8	18
	2							M10x20		50x10x8	
BG55	1.5	355	240	190	M14	M14	M14x28	M12x24	100x16x10	70x12x8	23
	2							M12x24		60x10x8	
BG75	1.5, 2	500	330	248	M16	M16	M16x32	M14x28	140x20x14	100x16x10	30



DIMENSIONI D'INGOMBRO / DIMENSIONS / DIMENSIONS D'ENCOMBREMENT / MAßE

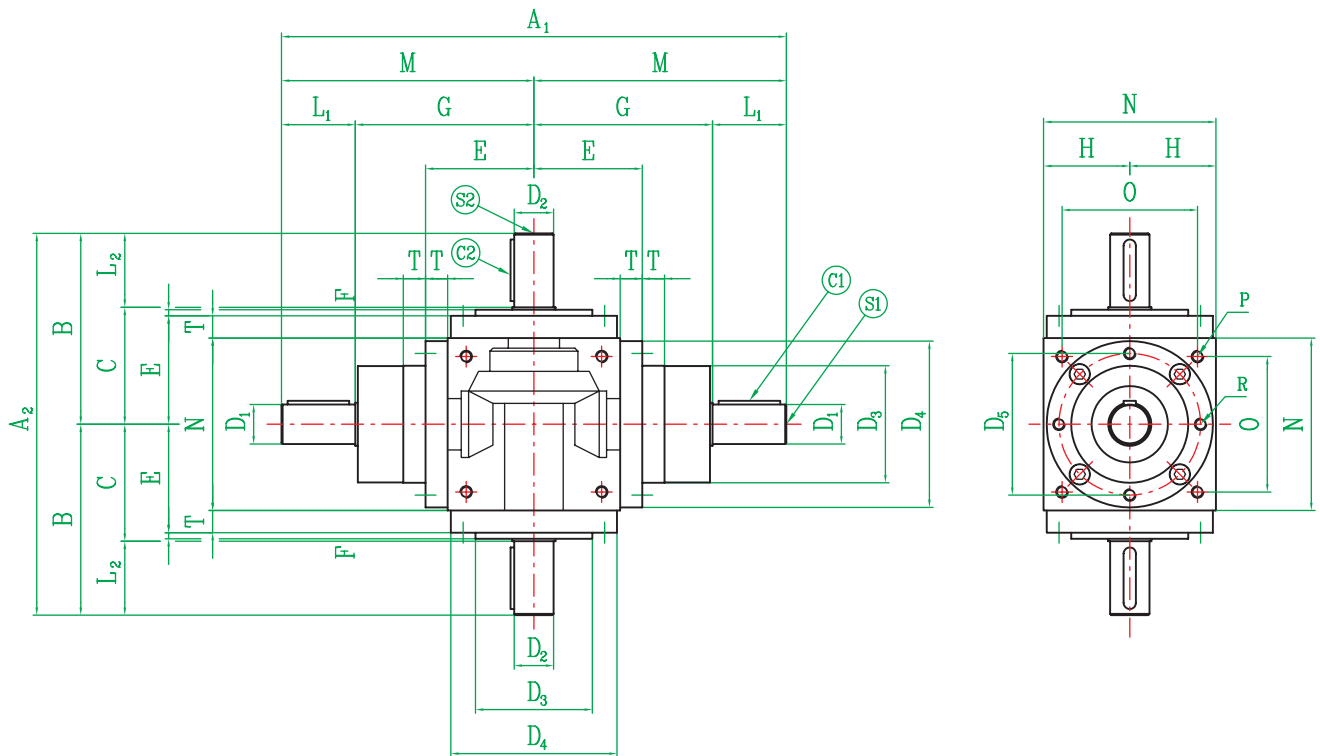

Taglia Size Taille Bautgröße	Rapporto Ratio Rapport Übersetzung	A <sub>1</sub>	A <sub>2</sub>	B	C	D <sub>1</sub>	D <sub>2</sub>	D <sub>3</sub>	D <sub>4</sub>	D <sub>5</sub>	E	F	G	H	L <sub>1</sub>	L <sub>2</sub>
BG12	1, 2, 3	200	144	72	46	12 j <sub>6</sub>	12 j <sub>6</sub>	44 h <sub>7</sub>	65 **	54	42	2	74	32.5	26	26
BG19	1, 2, 3	280	210	105	65	19 j <sub>6</sub>	19 j <sub>6</sub>	60 h <sub>7</sub>	86 h <sub>7</sub>	72	59	4	100	45	40	40
	4, 5	260				14 j <sub>6</sub>									30	
BG24	1, 2, 3	330	260	130	80	24 j <sub>6</sub>	24 j <sub>6</sub>	70 h <sub>7</sub>	105 h <sub>7</sub>	88	73	5	115	55	50	50
	4, 5	310				19 j <sub>6</sub>									40	
BG32	1, 2, 3	410	310	155	95	32 j <sub>6</sub>	32 j <sub>6</sub>	95 h <sub>7</sub>	135 h <sub>7</sub>	115	88	5	145	70	60	60
	4, 5	390				24 j <sub>6</sub>									50	
BG38	1, 2, 3	480	360	180	110	38 j <sub>6</sub>	38 j <sub>6</sub>	120 h <sub>7</sub>	165 h <sub>7</sub>	145	103	5	170	85	70	70
	4, 5	460				28 j <sub>6</sub>									60	
BG42	1, 2, 3	550	410	205	125	42 j <sub>6</sub>	42 j <sub>6</sub>	135 h <sub>7</sub>	190 h <sub>7</sub>	165	118	5	195	100	80	80
	4, 5	510				32 j <sub>6</sub>									60	
BG55	1, 2, 3	710	520	260	150	55 j <sub>6</sub>	55 j <sub>6</sub>	170 h <sub>7</sub>	230 h <sub>7</sub>	205	143	5	245	120	110	110
	4, 5	650				42 j <sub>6</sub>									80	
BG75	1, 2, 3	1000	750	375	225	75 j <sub>6</sub>	75 j <sub>6</sub>	220 *	300 h <sub>7</sub> *	--	195	16	350	165	150	150
	4, 5	920				55 j <sub>6</sub>		110								

\* Nel caso del rinvio angolare BG75 se occorre centrarsi su questo diametro chiedere informazioni al nostro ufficio tecnico / For spiral bevel gearbox BG75, please request further information to our engineering dept. to be able to centre on this diameter / Dans le cas du renvoi d'angle BG75, s'il faut que le centrage se produise sur ce diamètre, faire appel à notre service d'assistance technique / Sollte es im Falle des Winkel-Vorgeleges BG75 erforderlich sein, sich auf diesen Durchmesser zu zentrieren, sind bei unserer technischen Abteilung Informationen einzuholen.





\*\* Il diametro non è in tolleranza / Diameter is out of tolerance / Le diamètre n'est pas en tolérance / Der Durchmesser ist nicht in Toleranz.



**POSIZIONI DI MONTAGGIO / MOUNTING POSITION**  
**POSITIONS DE MONTAGE / EINBAULAGEN - KEGELRADGETRIEBE**

Schema superiore: Vista dal fianco - Schema inferiore: Vista dall'alto  
 Top diagram: Side view - Bottom diagram: Top view  
 Schéma supérieur: Vu de côté - Schéma inférieur: Vue d'en haut  
 Seitenansicht - Draufsicht

	Sfiato / Breather plug Évent / Einfüll Entlüftungsstopfen
	Livello / Level plug Niveau / Ölstandanzeige
	Scarico / Drain plug Vidange / Ablasschraube

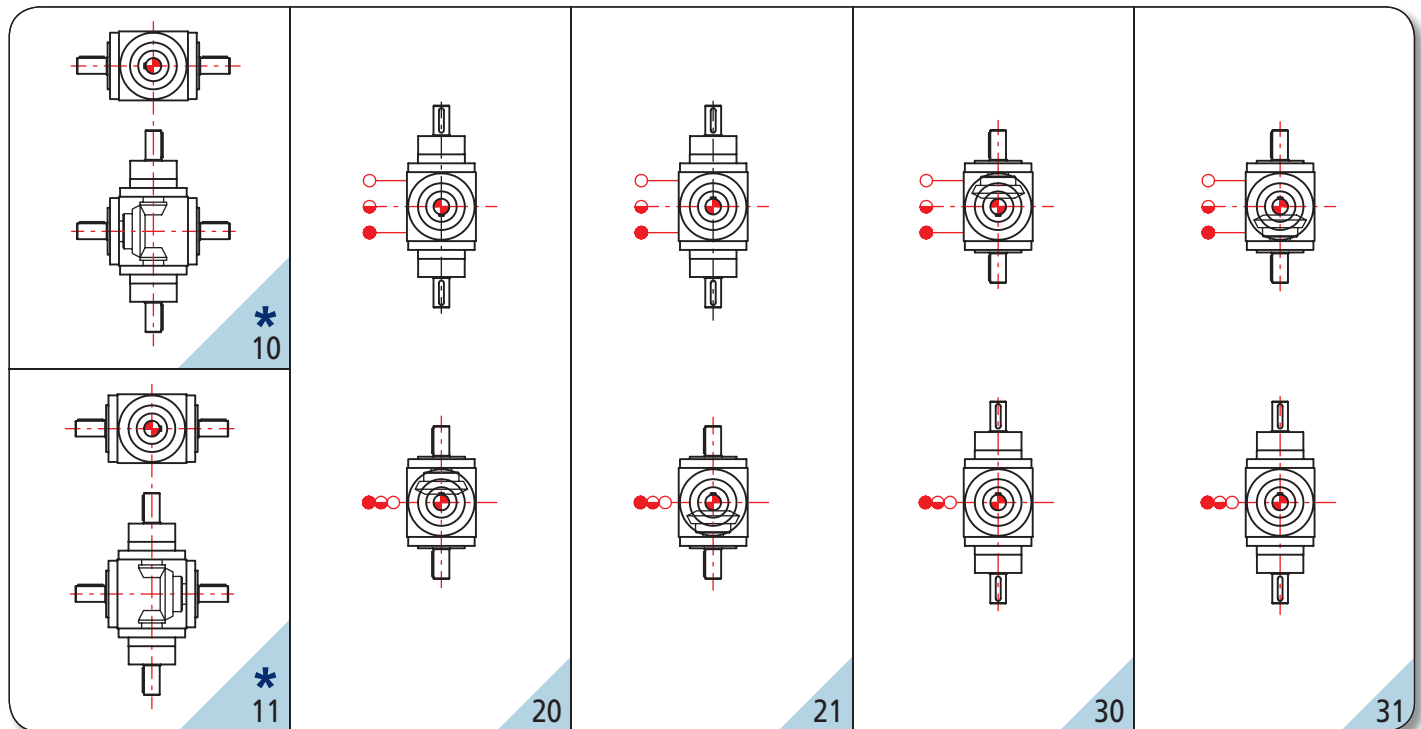

\* Per la lubrificazione ad OLIO interpellare ns. Ufficio Tecnico. / Normally grease lubricated. For particular applications, please, consult our technical department / Pour la lubrification à l'HUILE contacter notre bureau technique / Serienmäßig Fettschmierung. Für besondere Anwendung wenden Sie sich an unsere technische Abteilung.

Taglia Size Taille Bautröße	Rapporto Ratio Rapport Übersetzung	M	N	O	P	R	S1	S2	C1	C2	T
BG12	1, 2, 3	100	65	45	M6 ***	M6	M4x8	M4x8	20x4x4	20x4x4	9.5
BG19	1, 2, 3	140	90	70	M6	M6	M6x12	M6x12	35x6x6	35x6x6	14
	4, 5	130					M5x10		25x5x5		
BG24	1, 2, 3	165	110	88	M8	M8	M8x16	M8x16	40x8x7	40x8x7	18
	4, 5	155					M6x12		35x6x6		
BG32	1, 2, 3	205	140	110	M10	M10	M10x20	M10x20	50x10x8	50x10x8	18
	4, 5	195					M8x16		40x8x7		
BG38	1, 2, 3	240	170	136	M12	M12	M12x24	M12x24	60x10x8	60x10x8	18
	4, 5	230					M10x20		50x8x7		
BG42	1, 2, 3	275	200	155	M12	M12	M12x24	M12x24	70x12x8	70x12x8	18
	4, 5	255					M10x20		50x10x8		
BG55	1, 2, 3	355	240	190	M14	M14	M14x28	M14x28	100x16x10	100x16x10	23
	4, 5	325					M12x24		70x12x8		
BG75	1, 2, 3	500	330	248	M16	M16	M16x32	M16x32	140x20x14	140x20x14	30
	4, 5	460					M14x28		100x16x10		

\*\*\* Nella grandezza BG12 i fori "P" di interasse "O" sono presenti solamente sulle facce libere.

On BG12 size the holes P at centres O are only available on the side.

Dans la taille BG12 les trous «P» d'entraxe «O» sont présents seulement sur les côtés libres.

Bei der Baugröße BG12 sind die Bohrungen P mit dem Lochabstand O nur auf den Seiten ohne Wellen vorhanden.



DIMENSIONI D'INGOMBRO / DIMENSIONS / DIMENSIONS D'ENCOMBREMENT / MAßE

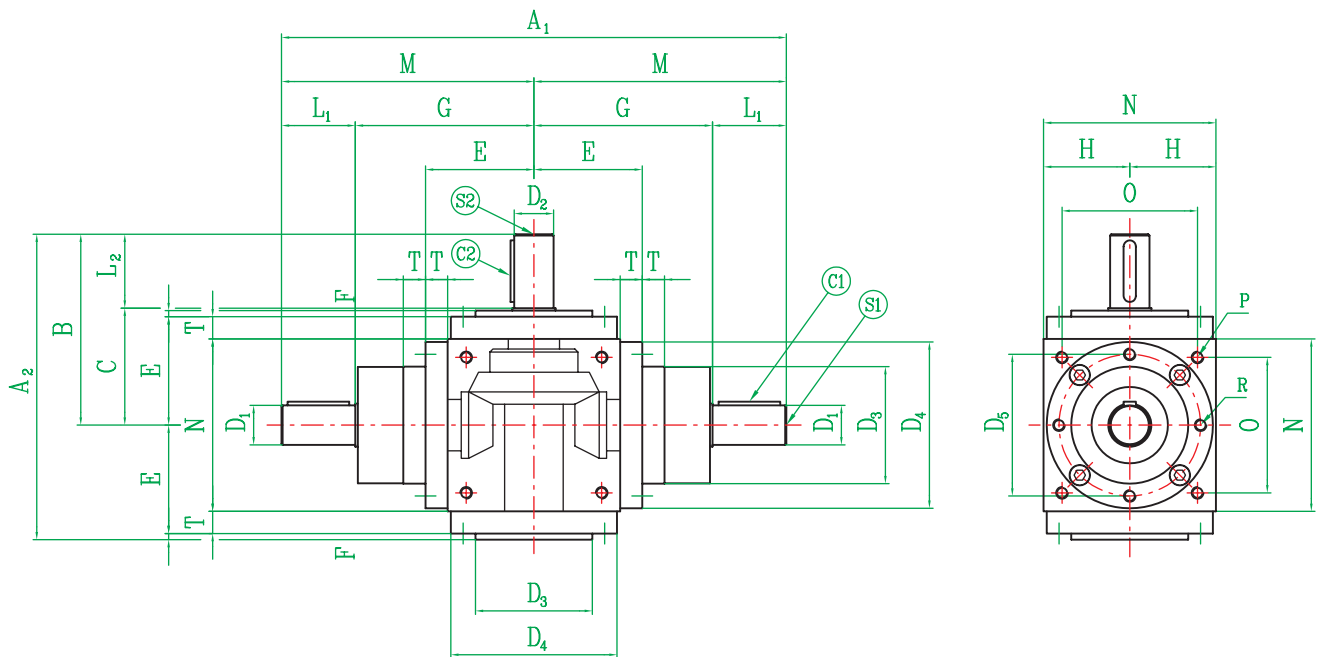

Taglia Size Taille Bautgröße	Rapporto Ratio Rapport Übersetzung	A <sub>1</sub>	A <sub>2</sub>	B	C	D <sub>1</sub>	D <sub>2</sub>	D <sub>3</sub>	D <sub>4</sub>	D <sub>5</sub>	E	F	G	H	L <sub>1</sub>	L <sub>2</sub>
BG12	1, 2, 3	200	116	72	46	12 j <sub>6</sub>	12 j <sub>6</sub>	44 h <sub>7</sub>	65 **	54	42	2	74	32.5	26	26
BG19	1, 2, 3	280	168	105	65	19 j <sub>6</sub>	19 j <sub>6</sub>	60 h <sub>7</sub>	86 h <sub>7</sub>	72	59	4	100	45	40	40
	4, 5	260				14 j <sub>6</sub>									30	
BG24	1, 2, 3	330	208	130	80	24 j <sub>6</sub>	24 j <sub>6</sub>	70 h <sub>7</sub>	105 h <sub>7</sub>	88	73	5	115	55	50	50
	4, 5	310				19 j <sub>6</sub>									40	
BG32	1, 2, 3	410	248	155	95	32 j <sub>6</sub>	32 j <sub>6</sub>	95 h <sub>7</sub>	135 h <sub>7</sub>	115	88	5	145	70	60	60
	4, 5	390				24 j <sub>6</sub>									50	
BG38	1, 2, 3	480	288	180	110	38 j <sub>6</sub>	38 j <sub>6</sub>	120 h <sub>7</sub>	165 h <sub>7</sub>	145	103	5	170	85	70	70
	4, 5	460				28 j <sub>6</sub>									60	
BG42	1, 2, 3	550	328	205	125	42 j <sub>6</sub>	42 j <sub>6</sub>	135 h <sub>7</sub>	190 h <sub>7</sub>	165	118	5	195	100	80	80
	4, 5	510				32 j <sub>6</sub>									60	
BG55	1, 2, 3	710	408	260	150	55 j <sub>6</sub>	55 j <sub>6</sub>	170 h <sub>7</sub>	230 h <sub>7</sub>	205	143	5	245	120	110	110
	4, 5	650				42 j <sub>6</sub>									80	
BG75	1, 2, 3	1000	598	375	225	75 j <sub>6</sub>	75 j <sub>6</sub>	220 *	300 h <sub>7</sub> *	--	195	16	350	165	150	150
	4, 5	920				55 j <sub>6</sub>		110								



\* Nel caso del rinvio angolare BG75 se occorre centrarsi su questo diametro chiedere informazioni al nostro ufficio tecnico / For spiral bevel gearbox BG75, please request further information to our engineering dept. to be able to centre on this diameter / Dans le cas du renvoi d'angle BG75, s'il faut que le centrage se produise sur ce diamètre, faire appel à notre service d'assistance technique / Sollte es im Falle des Winkel-Vorgeleges BG75 erforderlich sein, sich auf diesen Durchmesser zu zentrieren, sind bei unserer technischen Abteilung Informationen einzuholen.



\*\* Il diametro non è in tolleranza / Diameter is out of tolerance / Le diamètre n'est pas en tolérance / Der Durchmesser ist nicht in Toleranz.

**POSIZIONI DI MONTAGGIO / MOUNTING POSITION**  
**POSITIONS DE MONTAGE / EINBAULAGEN - KEGELRADGETRIEBE**

Schema superiore: Vista dal fianco - Schema inferiore: Vista dall'alto  
 Top diagram: Side view - Bottom diagram: Top view  
 Schéma supérieur: Vu de côté - Schéma inférieur: Vue d'en haut  
 Seitenansicht - Draufsicht

	Sfiato / Breather plug Évent / Einfüll Entlüftungsstopfen
	Livello / Level plug Niveau / Ölstandanzeige
	Scarico / Drain plug Vidange / Ablasschraube

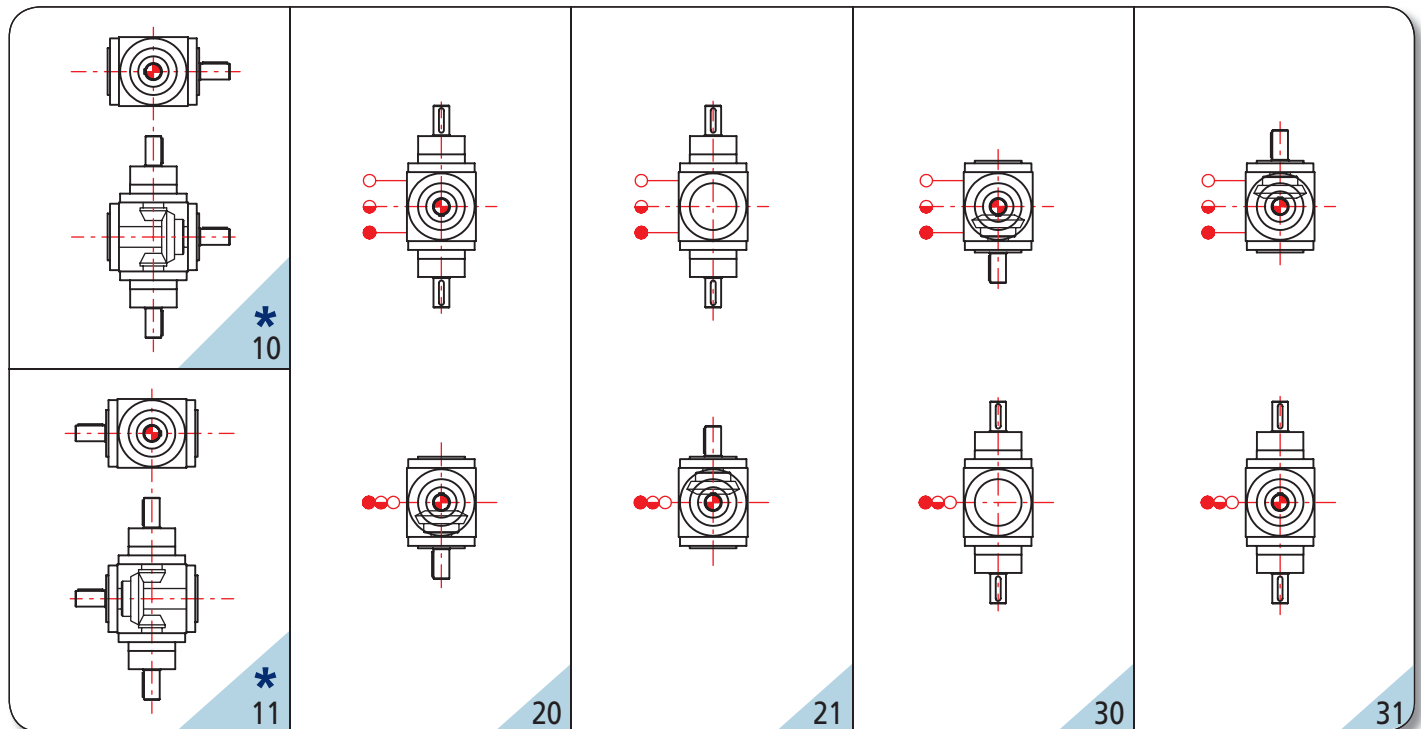

\* Per la lubrificazione ad OLIO interpellare ns. Ufficio Tecnico. / Normally grease lubricated. For particular applications, please, consult our technical department / Pour la lubrification à l'HUILE contacter notre bureau technique / Serienmäßig Fettschmierung. Für besondere Anwendung wenden Sie sich an unsere technische Abteilung.

Taglia Size Taille Bautröße	Rapporto Ratio Rapport Übersetzung	M	N	O	P	R	S1	S2	C1	C2	T
BG12	1, 2, 3	100	65	45	M6 ***	M6	M4x8	M4x8	20x4x4	20x4x4	9.5
BG19	1, 2, 3	140	90	70	M6	M6	M6x12	M6x12	35x6x6	35x6x6	14
	4, 5	130					M5x10		25x5x5		
BG24	1, 2, 3	165	110	88	M8	M8	M8x16	M8x16	40x8x7	40x8x7	18
	4, 5	155					M6x12		35x6x6		
BG32	1, 2, 3	205	140	110	M10	M10	M10x20	M10x20	50x10x8	50x10x8	18
	4, 5	195					M8x16		40x8x7		
BG38	1, 2, 3	240	170	136	M12	M12	M12x24	M12x24	60x10x8	60x10x8	18
	4, 5	230					M10x20		50x8x7		
BG42	1, 2, 3	275	200	155	M12	M12	M12x24	M12x24	70x12x8	70x12x8	18
	4, 5	255					M10x20		50x10x8		
BG55	1, 2, 3	355	240	190	M14	M14	M14x28	M14x28	100x16x10	100x16x10	23
	4, 5	325					M12x24		70x12x8		
BG75	1, 2, 3	500	330	248	M16	M16	M16x32	M16x32	140x20x14	140x20x14	30
	4, 5	460					M14x28		100x16x10		

\*\*\* Nella grandezza BG12 i fori "P" di interasse "O" sono presenti solamente sulle facce libere.

On BG12 size the holes P at centres O are only available on the side.

Dans la taille BG12 les trous «P» d'entraxe «O» sont présents seulement sur les côtés libres.

Bei der Baugröße BG12 sind die Bohrungen P mit dem Lochabstand O nur auf den Seiten ohne Wellen vorhanden.



## DIMENSIONI D'INGOMBRO / DIMENSIONS / DIMENSIONS D'ENCOMBREMENT / MAßE

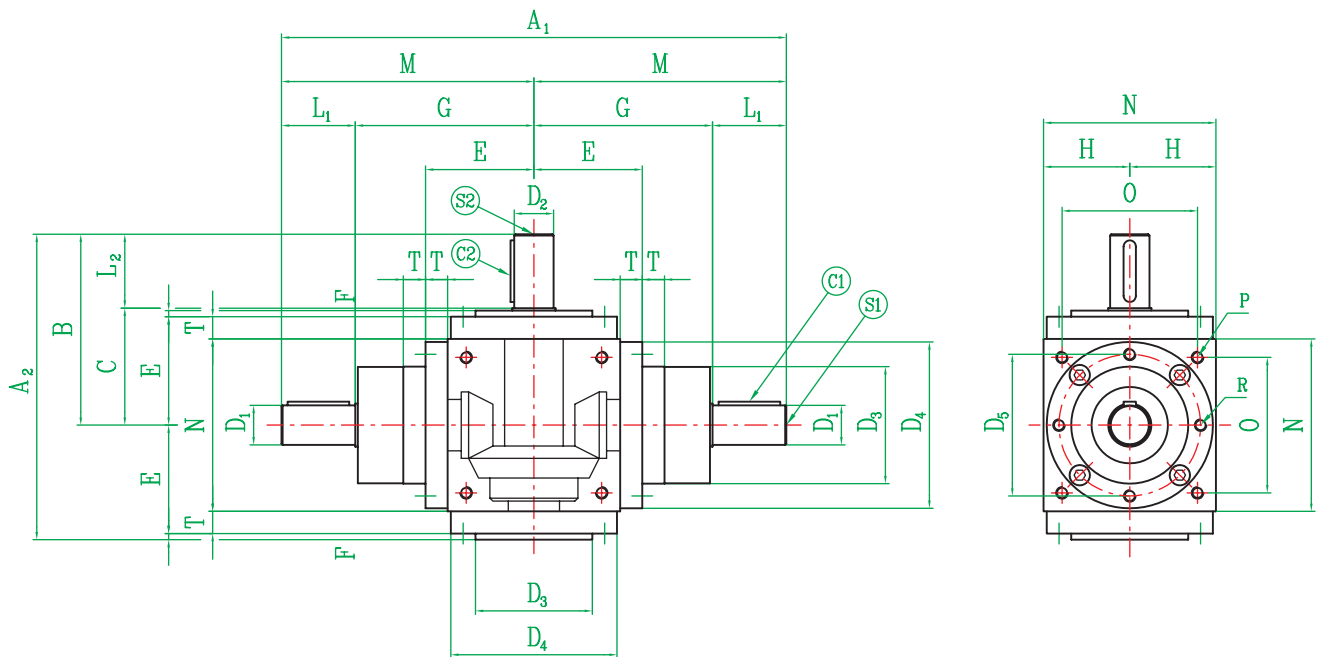

Taglia Size Taille Bautgröße	Rapporto Ratio Rapport Übersetzung	A <sub>1</sub>	A <sub>2</sub>	B	C	D <sub>1</sub>	D <sub>2</sub>	D <sub>3</sub>	D <sub>4</sub>	D <sub>5</sub>	E	F	G	H	L <sub>1</sub>	L <sub>2</sub>
BG12	1, 2, 3	200	116	72	46	12 j <sub>6</sub>	12 j <sub>6</sub>	44 h <sub>7</sub>	65 **	54	42	2	74	32.5	26	26
BG19	1, 2, 3	280	168	105	65	19 j <sub>6</sub>	19 j <sub>6</sub>	60 h <sub>7</sub>	86 h <sub>7</sub>	72	59	4	100	45	40	40
	4, 5	260				30									30	
BG24	1, 2, 3	330	208	130	80	24 j <sub>6</sub>	24 j <sub>6</sub>	70 h <sub>7</sub>	105 h <sub>7</sub>	88	73	5	115	55	50	50
	4, 5	310				40									40	
BG32	1, 2, 3	410	248	155	95	32 j <sub>6</sub>	32 j <sub>6</sub>	95 h <sub>7</sub>	135 h <sub>7</sub>	115	88	5	145	70	60	60
	4, 5	390				50									50	
BG38	1, 2, 3	480	288	180	110	38 j <sub>6</sub>	38 j <sub>6</sub>	120 h <sub>7</sub>	165 h <sub>7</sub>	145	103	5	170	85	70	70
	4, 5	460				60									60	
BG42	1, 2, 3	550	328	205	125	42 j <sub>6</sub>	42 j <sub>6</sub>	135 h <sub>7</sub>	190 h <sub>7</sub>	165	118	5	195	100	80	80
	4, 5	510				60									60	
BG55	1, 2, 3	710	408	260	150	55 j <sub>6</sub>	55 j <sub>6</sub>	170 h <sub>7</sub>	230 h <sub>7</sub>	205	143	5	245	120	110	110
	4, 5	650				80									80	
BG75	1, 2, 3	1000	598	375	225	75 j <sub>6</sub>	75 j <sub>6</sub>	220 *	300 h <sub>7</sub> *	--	195	16	350	165	150	150
	4, 5	920				110		110								

\* Nel caso del rinvio angolare BG75 se occorre centrarsi su questo diametro chiedere informazioni al nostro ufficio tecnico / For spiral bevel gearbox BG75, please request further information to our engineering dept. to be able to centre on this diameter / Dans le cas du renvoi d'angle BG75, s'il faut que le centrage se produise sur ce diamètre, faire appel à notre service d'assistance technique / Sollte es im Falle des Winkel-Vorgeleges BG75 erforderlich sein, sich auf diesen Durchmesser zu zentrieren, sind bei unserer technischen Abteilung Informationen einzuholen.



\*\* Il diametro non è in tolleranza / Diameter is out of tolerance / Le diamètre n'est pas en tolérance / Der Durchmesser ist nicht in Toleranz.

**POSIZIONI DI MONTAGGIO / MOUNTING POSITION**  
**POSITIONS DE MONTAGE / EINBAULAGEN - KEGELRADGETRIEBE**

Schema superiore: Vista dal fianco - Schema inferiore: Vista dall'alto  
 Top diagram: Side view - Bottom diagram: Top view  
 Schéma supérieur: Vu de côté - Schéma inférieur: Vue d'en haut  
 Seitenansicht - Draufsicht

	Sfiato / Breather plug Évent / Einfüll Entlüftungsstopfen
	Livello / Level plug Niveau / Ölstandanzeige
	Scarico / Drain plug Vidange / Ablassschraube

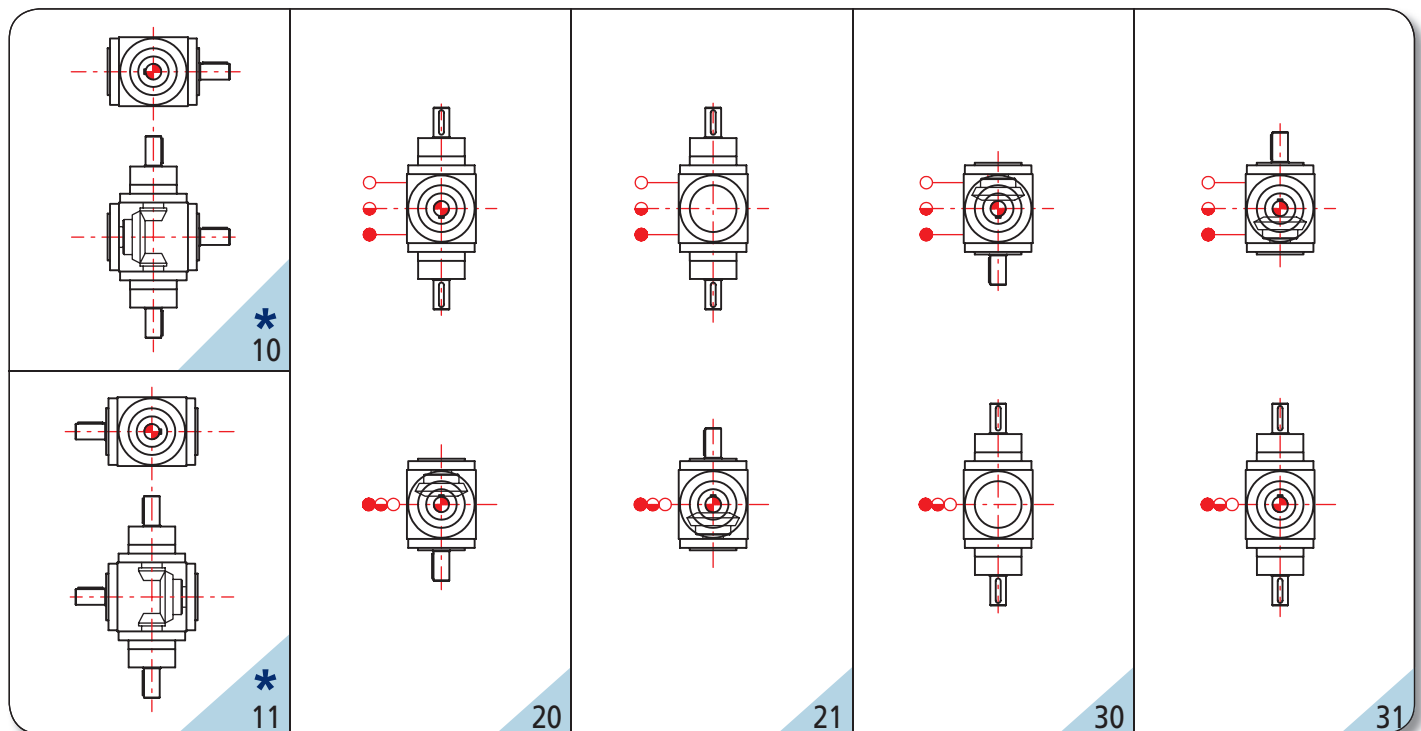

\* Per la lubrificazione ad OLIO interpellare ns. Ufficio Tecnico. / Normally grease lubricated. For particular applications, please, consult our technical department / Pour la lubrification à l'HUILE contacter notre bureau technique / Serienmäßig Fettschmierung. Für besondere Anwendung wenden Sie sich an unsere technische Abteilung.

Taglia Size Taille Bautröße	Rapporto Ratio Rapport Übersetzung	M	N	O	P	R	S1	S2	C1	C2	T
BG12	1, 2, 3	100	65	45	M6 ***	M6	M4x8	M4x8	20x4x4	20x4x4	9.5
BG19	1, 2, 3	140	90	70	M6	M6	M6x12	M6x12	35x6x6	35x6x6	14
	4, 5	130					M5x10		25x5x5		
BG24	1, 2, 3	165	110	88	M8	M8	M8x16	M8x16	40x8x7	40x8x7	18
	4, 5	155					M6x12		35x6x6		
BG32	1, 2, 3	205	140	110	M10	M10	M10x20	M10x20	50x10x8	50x10x8	18
	4, 5	195					M8x16		40x8x7		
BG38	1, 2, 3	240	170	136	M12	M12	M12x24	M12x24	60x10x8	60x10x8	18
	4, 5	230					M10x20		50x8x7		
BG42	1, 2, 3	275	200	155	M12	M12	M12x24	M12x24	70x12x8	70x12x8	18
	4, 5	255					M10x20		50x10x8		
BG55	1, 2, 3	355	240	190	M14	M14	M14x28	M14x28	100x16x10	100x16x10	23
	4, 5	325					M12x24		70x12x8		
BG75	1, 2, 3	500	330	248	M16	M16	M16x32	M16x32	140x20x14	140x20x14	30
	4, 5	460					M14x28		100x16x10		

\*\*\* Nella grandezza BG12 i fori "P" di interasse "O" sono presenti solamente sulle facce libere.

On BG12 size the holes P at centres O are only available on the side.

Dans la taille BG12 les trous «P» d'entraxe «O» sont présents seulement sur les côtés libres.

Bei der Baugröße BG12 sind die Bohrungen P mit dem Lochabstand O nur auf den Seiten ohne Wellen vorhanden.



DIMENSIONI D'INGOMBRO / DIMENSIONS / DIMENSIONS D'ENCOMBREMENT / MAßE

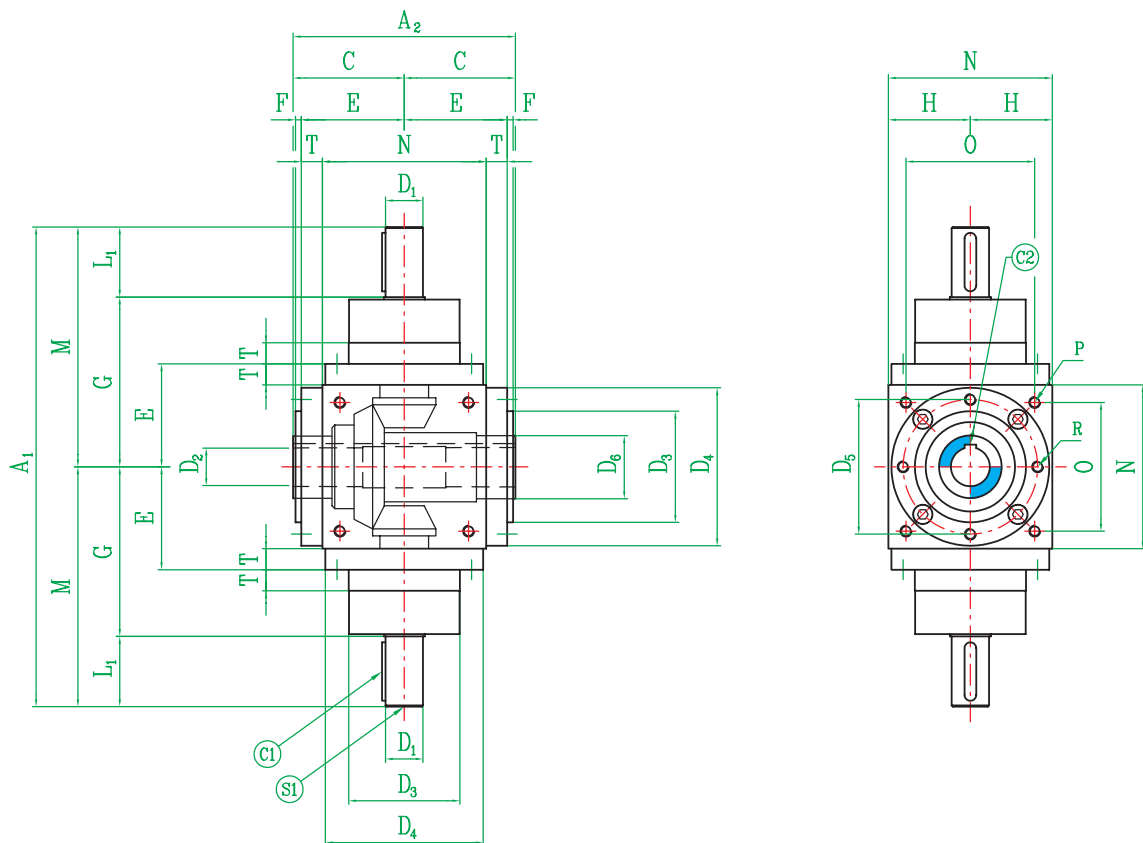

Taglia Size Taille Bautgröße	Rapporto Ratio Rapport Übersetzung	A <sub>1</sub>	A <sub>2</sub>	C	D <sub>1</sub>	D <sub>2</sub>	D <sub>3</sub>	D <sub>4</sub>	D <sub>5</sub>	D <sub>6</sub>	E	F	G	H
BG12	1, 2, 3	200	92	46	12 j <sub>6</sub>	12 H7	44 h7	65 **	54	20	42	2	74	32.5
BG19	1, 2, 3	280	130	65	19 j <sub>6</sub>	19 H7	60 h7	86 h7	72	30	59	4	100	45
	4, 5	260			14 j <sub>6</sub>									
BG24	1, 2, 3	330	160	80	24 j <sub>6</sub>	24 H7	70 h7	105 h7	88	35	73	5	115	55
	4, 5	310			19 j <sub>6</sub>									
BG32	1, 2, 3	410	190	95	32 j <sub>6</sub>	32 H7	95 h7	135 h7	115	50	88	5	145	70
	4, 5	390			24 j <sub>6</sub>									
BG38	1, 2, 3	480	220	110	38 j <sub>6</sub>	38 H7	120 h7	165 h7	145	60	103	5	170	85
	4, 5	460			28 j <sub>6</sub>									
BG42	1, 2, 3	550	250	125	42 j <sub>6</sub>	42 H7	135 h7	190 h7	165	60	118	5	195	100
	4, 5	510			32 j <sub>6</sub>									
BG55	1, 2, 3	710	300	150	55 j <sub>6</sub>	55 H7	170 h7	230 h7	205	75	143	5	245	120
	4, 5	650			42 j <sub>6</sub>									
BG75	1, 2, 3	1000	450	225	75 j <sub>6</sub>	75 H7	220 *	300 *	--	120	195	16	350	165
	4, 5	920			55 j <sub>6</sub>									

\* Nel caso del rinvio angolare BG75 se occorre centrarsi su questo diametro chiedere informazioni al nostro ufficio tecnico / For spiral bevel gearbox BG75, please request further information to our engineering dept. to be able to centre on this diameter / Dans le cas du renvoi d'angle BG75, s'il faut que le centrage se produise sur ce diamètre, faire appel à notre service d'assistance technique / Sollte es im Falle des Winkel-Vorgeleges BG75 erforderlich sein, sich auf diesen Durchmesser zu zentrieren, sind bei unserer technischen Abteilung Informationen einzuholen.



\*\* Il diametro non è in tolleranza / Diameter is out of tolerance / Le diamètre n'est pas en tolérance / Der Durchmesser ist nicht in Toleranz.

**POSIZIONI DI MONTAGGIO / MOUNTING POSITION**  
**POSITIONS DE MONTAGE / EINBAULAGEN - KEGELRADGETRIEBE**

Schema superiore: Vista dal fianco - Schema inferiore: Vista dall'alto  
 Top diagram: Side view - Bottom diagram: Top view  
 Schéma supérieur: Vu de côté - Schéma inférieur: Vue d'en haut  
 Seitenansicht - Draufsicht

	Sfiato / Breather plug Évent / Einfüll Entlüftungsstopfen
	Livello / Level plug Niveau / Ölstandanzeige
	Scarico / Drain plug Vidange / Ablassschraube

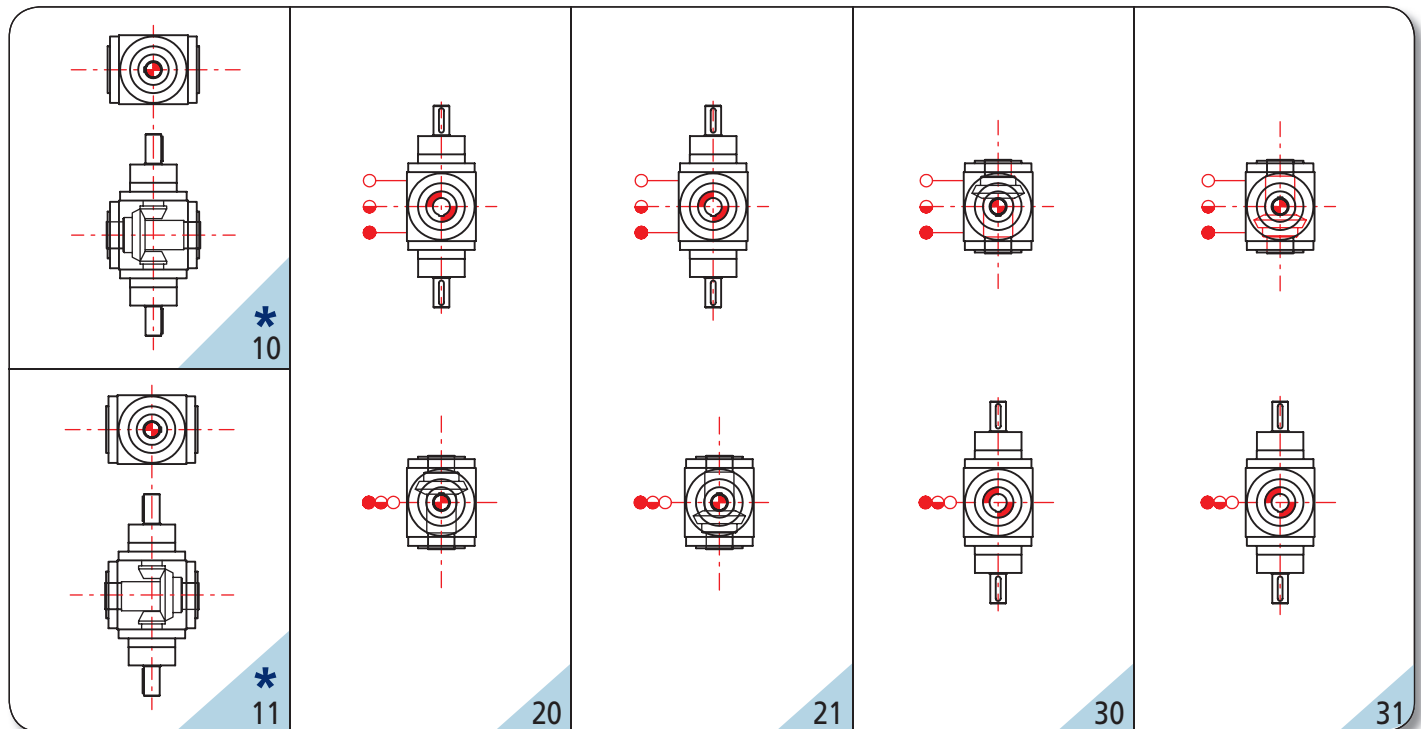

\* Per la lubrificazione ad OLIO interpellare ns. Ufficio Tecnico. / Normally grease lubricated. For particular applications, please, consult our technical department / Pour la lubrification à l'HUILE contacter notre bureau technique / Serienmäßig Fettschmierung. Für besondere Anwendung wenden Sie sich an unsere technische Abteilung.

Taglia Size Taille Bautröße	Rapporto Ratio Rapport Übersetzung	L <sub>1</sub>	M	N	O	P	R	S1	C1	C2	T
BG12	1, 2, 3	26	100	65	45	M6 ***	M6	M4x8	20x4x4	4x4	9.5
BG19	1, 2, 3	40	140	90	70	M6	M6	M6x12	35x6x6	6x6	14
	4, 5	30	130					M5x10	25x5x5		
BG24	1, 2, 3	50	165	110	88	M8	M8	M8x16	40x8x7	8x7	18
	4, 5	40	155					M6x12	35x6x6		
BG32	1, 2, 3	60	205	140	110	M10	M10	M10x20	50x10x8	10x8	18
	4, 5	50	195					M8x16	40x8x7		
BG38	1, 2, 3	70	240	170	136	M12	M12	M12x24	60x10x8	10x8	18
	4, 5	60	230					M10x20	50x8x7		
BG42	1, 2, 3	80	275	200	155	M12	M12	M12x24	70x12x8	12x8	18
	4, 5	60	255					M10x20	50x10x8		
BG55	1, 2, 3	110	355	240	190	M14	M14	M14x28	100x16x10	16x10	23
	4, 5	80	325					M12x24	70x12x8		
BG75	1, 2, 3	150	500	330	248	M16	M16	M16x32	140x20x14	20x14	30
	4, 5	110	460					M14x28	100x16x10		

\*\*\* Nella grandezza BG12 i fori "P" di interasse "O" sono presenti solamente sulle facce libere.

On BG12 size the holes P at centres O are only available on the side.

Dans la taille BG12 les trous «P» d'entraxe «O» sont présents seulement sur les côtés libres.

Bei der Baugröße BG12 sind die Bohrungen P mit dem Lochabstand O nur auf den Seiten ohne Wellen vorhanden.



DIMENSIONI D'INGOMBRO / DIMENSIONS / DIMENSIONS D'ENCOMBREMENT / MAßE

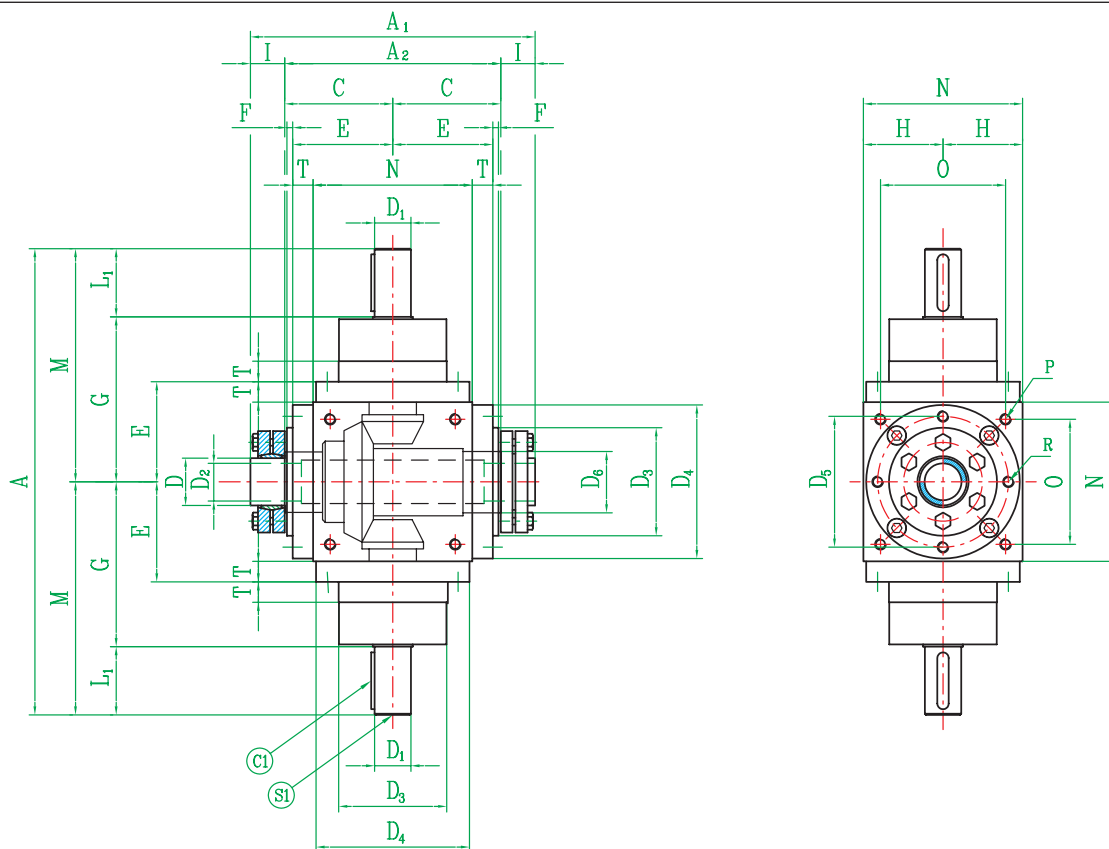

Taglia Size Taille Bautgröße	Rapporto Ratio Rapport Übersetzung	A	A <sub>1</sub>	A <sub>2</sub>	C	D	D <sub>1</sub>	D <sub>2</sub>	D <sub>3</sub>	D <sub>4</sub>	D <sub>5</sub>	D <sub>6</sub>	E	F	G
BG12	1, 2, 3	200	121	92	46	14 h7	12 j6	12 H7	44 h7	65**	54	38	42	2	74
BG19	1, 2, 3	280	178	130	65	24 h7	19 j6	19 H7	60 h7	86 h7	72	50	59	4	100
	4, 5	260					14 j6								
BG24	1, 2, 3	330	212	160	80	30 h7	24 j6	24 H7	70 h7	105 h7	88	60	73	5	115
	4, 5	310					19 j6								
BG32	1, 2, 3	410	250	190	95	44 h7	32 j6	32 H7	95 h7	135 h7	115	80	88	5	145
	4, 5	390					24 j6								
BG38	1, 2, 3	480	284	220	110	50 h7	38 j6	38 H7	120 h7	165 h7	145	90	103	5	170
	4, 5	460					28 j6								
BG42	1, 2, 3	550	320	250	125	55 h7	42 j6	42 H7	135 h7	190 h7	165	100	118	5	195
	4, 5	510					32 j6								
BG55	1, 2, 3	710	370	300	150	68 h7	55 j6	55 H7	170 h7	230 h7	205	115	143	5	245
	4, 5	650					42 j6								
BG75	1, 2, 3	1000	544	450	225	90 h7	75 j6	75 H7	220*	300 h7*	--	155	195	16	350
	4, 5	920					55 j6								

\* Nel caso del rinvio angolare BG75 se occorre centrarsi su questo diametro chiedere informazioni al nostro ufficio tecnico / For spiral bevel gearbox BG75, please request further information to our engineering dept. to be able to centre on this diameter / Dans le cas du renvoi d'angle BG75, s'il faut que le centrage se produise sur ce diamètre, faire appel à notre service d'assistance technique / Sollte es im Falle des Winkel-Vorgeleges BG75 erforderlich sein, sich auf diesen Durchmesser zu zentrieren, sind bei unserer technischen Abteilung Informationen einzuholen.





\*\* Il diametro non è in tolleranza / Diameter is out of tolerance / Le diamètre n'est pas en tolérance / Der Durchmesser ist nicht in Toleranz.



**POSIZIONI DI MONTAGGIO / MOUNTING POSITION**  
**POSITIONS DE MONTAGE / EINBAULAGEN - KEGELRADGETRIEBE**

Schema superiore: Vista dal fianco - Schema inferiore: Vista dall'alto  
 Top diagram: Side view - Bottom diagram: Top view  
 Schéma supérieur: Vu de côté - Schéma inférieur: Vue d'en haut  
 Seitenansicht - Draufsicht

	Sfiato / Breather plug Évent / Einfüll Entlüftungsstopfen
	Livello / Level plug Niveau / Ölstandanzeige
	Scarico / Drain plug Vidange / Ablasschraube

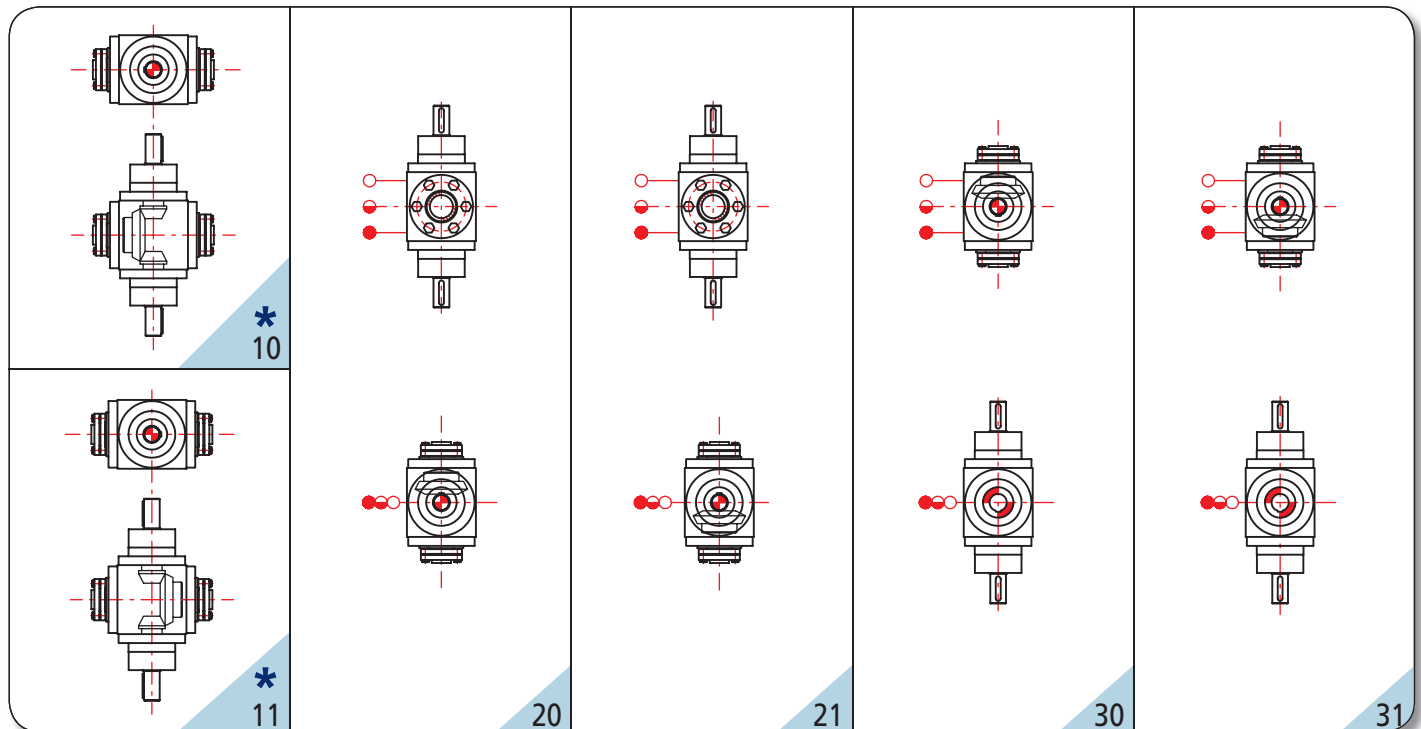

\* Per la lubrificazione ad OLIO interpellare ns. Ufficio Tecnico. / Normally grease lubricated. For particular applications, please, consult our technical department / Pour la lubrification à l'HUILE contacter notre bureau technique / Serienmäßig Fettschmierung. Für besondere Anwendung wenden Sie sich an unsere technische Abteilung.

Taglia Size Taille Bautgröße	Rapporto Ratio Rapport Übersetzung	H	I	M	L <sub>1</sub>	N	O	P	R	S1	C1	T
BG12	1, 2, 3	32.5	15	100	26	65	45	M6 ***	M6	M4x8	20x4x4	9.5
BG19	1, 2, 3	45	24	140	40	90	70	M6	M6	M6x12	35x6x6	14
	4, 5			130	30					M5x10	25x5x5	
BG24	1, 2, 3	55	26	165	50	110	88	M8	M8	M8x16	40x8x7	18
	4, 5			155	40					M6x12	35x6x6	
BG32	1, 2, 3	70	30	205	60	140	110	M10	M10	M10x20	50x10x8	18
	4, 5			195	50					M8x16	40x8x7	
BG38	1, 2, 3	85	32	240	70	170	136	M12	M12	M12x24	60x10x8	18
	4, 5			230	60					M10x20	50x8x7	
BG42	1, 2, 3	100	35	275	80	200	155	M12	M12	M12x24	70x12x8	18
	4, 5			255	60					M10x20	50x10x8	
BG55	1, 2, 3	120	35	355	110	240	190	M14	M14	M14x28	100x16x10	23
	4, 5			325	80					M12x24	70x12x8	
BG75	1, 2, 3	165	47	500	150	330	248	M16	M16	M16x32	140x20x14	30
	4, 5			460	110					M14x28	100x16x10	

\*\*\* Nella grandezza BG12 i fori "P" di interasse "O" sono presenti solamente sulle facce libere.

On BG12 size the holes P at centres O are only available on the side.

Dans la taille BG12 les trous «P» d'entraxe «O» sont présents seulement sur les côtés libres.

Bei der Baugroße BG12 sind die Bohrungen P mit dem Lochabstand O nur auf den Seiten ohne Wellen vorhanden.



DIMENSIONI D'INGOMBRO / DIMENSIONS / DIMENSIONS D'ENCOMBREMENT / MAßE

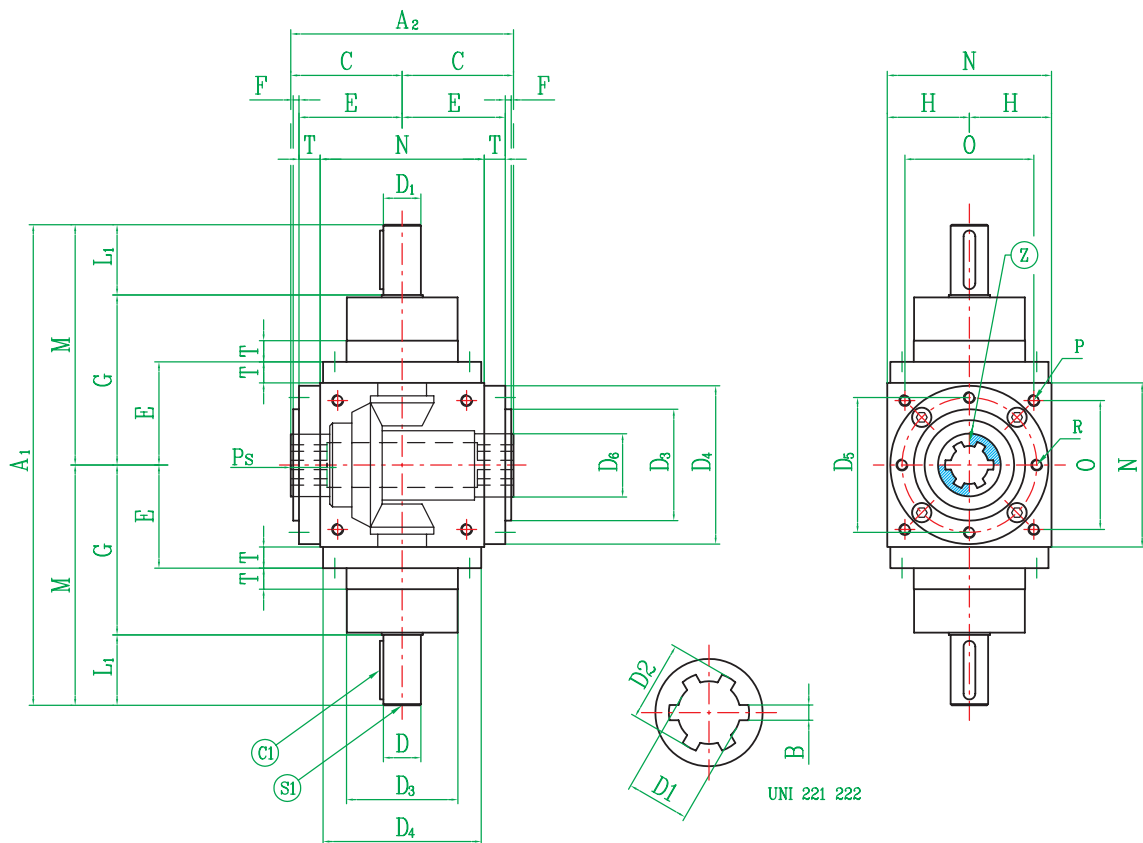

Taglia Size Taille Bautröße	Rapporto Ratio Rapport Übersetzung	A <sub>1</sub>	A <sub>2</sub>	C	D	Ps	D <sub>1</sub>	D <sub>2</sub>	B	D <sub>3</sub>	D <sub>4</sub>	D <sub>5</sub>	D <sub>6</sub>	E	F	G
BG12	1, 2, 3	200	92	46	12 j6	13	11	14	3	44 h7	65 **	54	20	42	2	74
BG19	1, 2, 3	280	130	65	19 j6	15	13	16	3.5	60 h7	86 h7	72	30	59	4	100
	4, 5	260			14 j6											
BG24	1, 2, 3	330	160	80	24 j6	20	18	22	5	70 h7	105 h7	88	35	73	5	115
	4, 5	310			19 j6											
BG32	1, 2, 3	410	190	95	32 j6	25	21	25	5	95 h7	135 h7	115	50	88	5	145
	4, 5	390			24 j6											
BG38	1, 2, 3	480	220	110	38 j6	30	28	34	7	120 h7	165 h7	145	60	103	5	170
	4, 5	460			28 j6											
BG42	1, 2, 3	550	250	125	42 j6	35	36	42	7	135 h7	190 h7	165	60	118	5	195
	4, 5	510			32 j6											
BG55	1, 2, 3	710	300	150	55 j6	40	46	54	8	170 h7	230 h7	205	75	143	5	245
	4, 5	650			42 j6											
BG75	1, 2, 3	1000	450	225	75 j6	50	72	82	12	220 *	300 h7 *	--	120	195	16	350
	4, 5	920			55 j6											



\* Nel caso del rinvio angolare BG75 se occorre centrarsi su questo diametro chiedere informazioni al nostro ufficio tecnico / For spiral bevel gearbox BG75, please request further information to our engineering dept. to be able to centre on this diameter / Dans le cas du renvoi d'angle BG75, s'il faut que le centrage se produise sur ce diamètre, faire appel à notre service d'assistance technique / Sollte es im Falle des Winkel-Vorgeleges BG75 erforderlich sein, sich auf diesen Durchmesser zu zentrieren, sind bei unserer technischen Abteilung Informationen einzuholen.



\*\* Il diametro non è in tolleranza / Diameter is out of tolerance / Le diamètre n'est pas en tolérance / Der Durchmesser ist nicht in Toleranz.

**POSIZIONI DI MONTAGGIO / MOUNTING POSITION**  
**POSITIONS DE MONTAGE / EINBAULAGEN - KEGELRADGETRIEBE**

Schema superiore: Vista dal fianco - Schema inferiore: Vista dall'alto  
 Top diagram: Side view - Bottom diagram: Top view  
 Schéma supérieur: Vu de côté - Schéma inférieur: Vue d'en haut  
 Seitenansicht - Draufsicht

	Sfiato / Breather plug Évent / Einfüll Entlüftungsstopfen
	Livello / Level plug Niveau / Ölstandanzeige
	Scarico / Drain plug Vidange / Ablasschraube

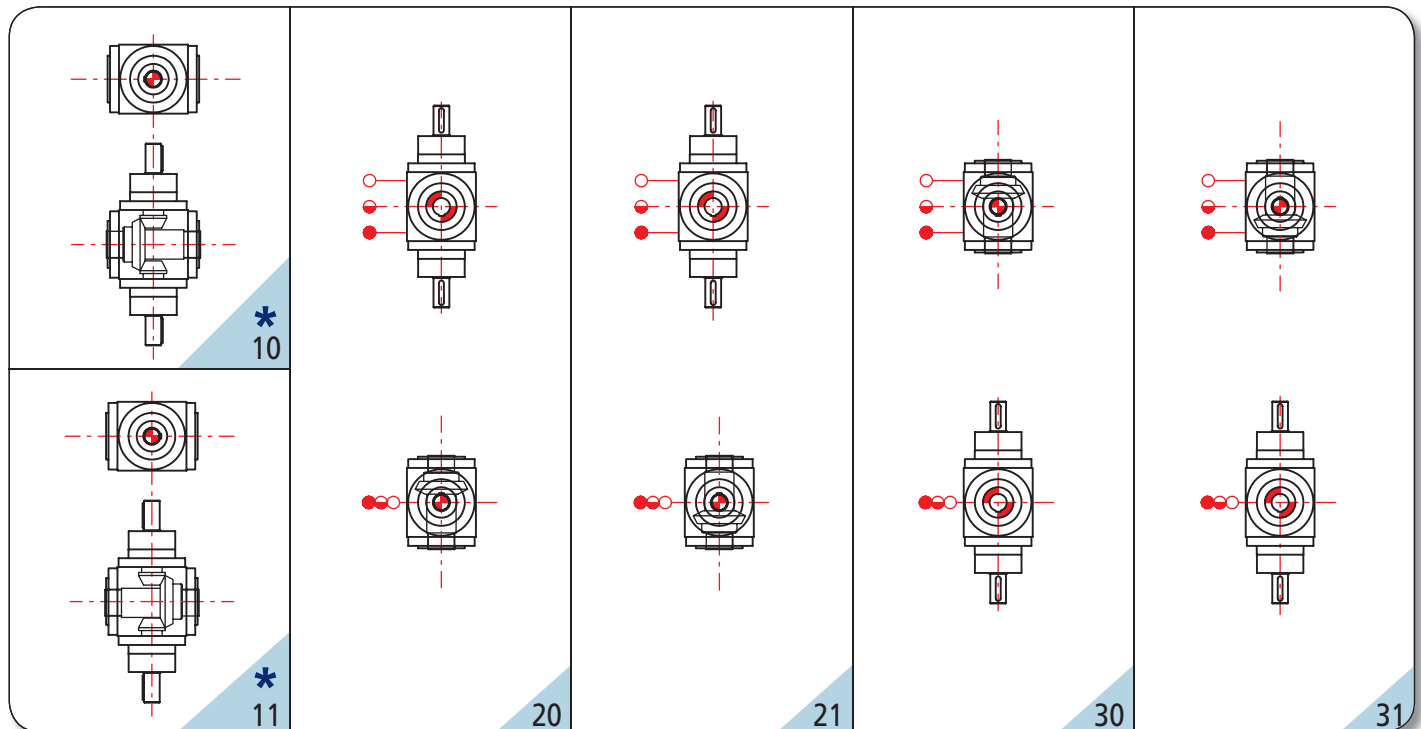

\* Per la lubrificazione ad OLIO interpellare ns. Ufficio Tecnico. / Normally grease lubricated. For particular applications, please, consult our technical department / Pour la lubrification à l'HUILE contacter notre bureau technique / Serienmäßig Fettschmierung. Für besondere Anwendung wenden Sie sich an unsere technische Abteilung.

Taglia Size Taille Bautröße	Rapporto Ratio Rapport Übersetzung	H	L <sub>1</sub>	M	N	O	P	R	S1	C1	Z	T
BG12	1, 2, 3	32.5	26	100	65	45	M6 ***	M6	M4x8	20x4x4	6	9.5
BG19	1, 2, 3	45	40	140	90	70	M6	M6	M6x12	35x6x6	6	14
	4, 5		30	130					M5x10	25x5x5		
BG24	1, 2, 3	55	50	165	110	88	M8	M8	M8x16	40x8x7	6	18
	4, 5		40	155					M6x12	35x6x6		
BG32	1, 2, 3	70	60	205	140	110	M10	M10	M10x20	50x10x8	6	18
	4, 5		50	195					M8x16	40x8x7		
BG38	1, 2, 3	85	70	240	170	136	M12	M12	M12x24	60x10x8	6	18
	4, 5		60	230					M10x20	50x8x7		
BG42	1, 2, 3	100	80	275	200	155	M12	M12	M12x24	70x12x8	8	18
	4, 5		60	255					M10x20	50x10x8		
BG55	1, 2, 3	120	110	355	240	190	M14	M14	M14x28	100x16x10	8	23
	4, 5		80	325					M12x24	70x12x8		
BG75	1, 2, 3	165	150	500	330	248	M16	M16	M16x32	140x20x14	10	30
	4, 5		110	460					M14x28	100x16x10		

\*\*\* Nella grandezza BG12 i fori "P" di interasse "O" sono presenti solamente sulle facce libere.

On BG12 size the holes P at centres O are only available on the side.

Dans la taille BG12 les trous «P» d'entraxe «O» sont présents seulement sur les côtés libres.

Bei der Baugroße BG12 sind die Bohrungen P mit dem Lochabstand O nur auf den Seiten ohne Wellen vorhanden.



## DIMENSIONI D'INGOMBRO / DIMENSIONS / DIMENSIONS D'ENCOMBREMENT / MAßE

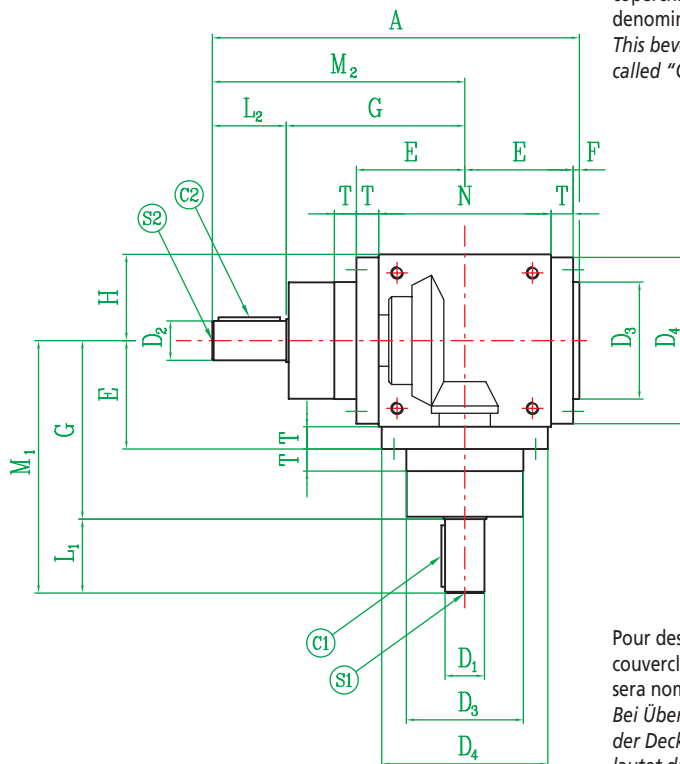

Per rapporti diversi da 1/1 il rinvio rappresentato viene denominato "CR". Nel caso il coperchio cieco venga montato in posizione opposta all'albero veloce, il rinvio viene denominato "CX".

*This bevel gearbox is called "CR" for ratio's other than 1:1. The bevel gearbox is called "CX" when the blind cover is mounted opposite the high speed shaft.*

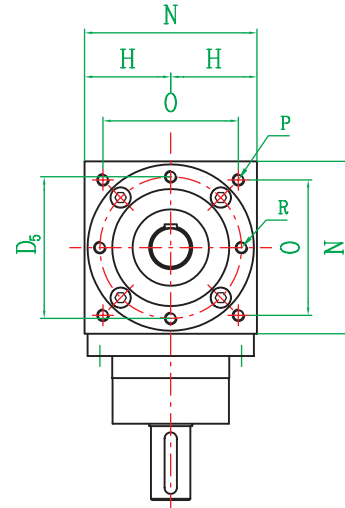

Pour des rapports autres que 1/1 le renvoi représenté est nommé « CR ». Au cas où le couvercle borgne serait monté dans une position opposée à l'arbre rapide, le renvoi sera nommé « CX ».

*Bei Übersetzungen größer als 1:1 wird das kegelradgetriebe mit CR bezeichnet. Wird der Deckel auf der gegenüberliegenden Seite der schnelllaufenden Welle montiert, lautet die Bezeichnung CX.*

Taglia Size Taille Bautröße	Rapporto Ratio Rapport Übersetzung	A	D <sub>1</sub>	D <sub>2</sub>	D <sub>3</sub>	D <sub>4</sub>	D <sub>5</sub>	E	F	G	H	L <sub>1</sub>	L <sub>2</sub>	M <sub>1</sub>	M <sub>2</sub>
BG12	1, 2, 3	144	12 j6	12 j6	44 h7	65 **	54	42	2	74	32.5	26	26	100	100
BG19	1, 2, 3	203	19 j6	19 j6	60 h7	86 h7	72	59	4	100	45	40	40	140	140
	4, 5		30									130			
BG24	1, 2, 3	243	24 j6	24 j6	70 h7	105 h7	88	73	5	115	55	50	50	165	165
	4, 5		40									155			
BG32	1, 2, 3	298	32 j6	32 j6	95 h7	135 h7	115	88	5	145	70	60	60	205	205
	4, 5		50									195			
BG38	1, 2, 3	348	38 j6	38 j6	120 h7	165 h7	145	103	5	170	85	70	70	240	240
	4, 5		60									230			
BG42	1, 2, 3	398	42 j6	42 j6	135 h7	190 h7	165	118	5	195	100	80	80	275	275
	4, 5		60									255			
BG55	1, 2, 3	503	55 j6	55 j6	170 h7	230 h7	205	143	5	245	120	110	110	355	355
	4, 5		80									325			
BG75	1, 2, 3	723	75 j6	75 j6	220 *	300 h7 *	--	195	16	350	165	150	150	500	500
	4, 5		110		460										

\* Nel caso del rinvio angolare BG75 se occorre centrarsi su questo diametro chiedere informazioni al nostro ufficio tecnico / For spiral bevel gearbox BG75, please request further information to our engineering dept. to be able to centre on this diameter / Dans le cas du renvoi d'angle BG75, s'il faut que le centrage se produise sur ce diamètre, faire appel à notre service d'assistance technique / Sollte es im Falle des Winkel-Vorgeleges BG75 erforderlich sein, sich auf diesen Durchmesser zu zentrieren, sind bei unserer technischen Abteilung Informationen einzuholen.

\*\* Il diametro non è in tolleranza / Diameter is out of tolerance / Le diamètre n'est pas en tolérance / Der Durchmesser ist nicht in Toleranz.



**POSIZIONI DI MONTAGGIO / MOUNTING POSITION**  
**POSITIONS DE MONTAGE / EINBAULAGEN - KEGELRADGETRIEBE**

Schema superiore: Vista dal fianco - Schema inferiore: Vista dall'alto  
 Top diagram: Side view - Bottom diagram: Top view  
 Schéma supérieur: Vu de côté - Schéma inférieur: Vue d'en haut  
 Seitenansicht - Draufsicht

	Sfiato / Breather plug Évent / Einfüll Entlüftungsstopfen
	Livello / Level plug Niveau / Ölstandanzeige
	Scarico / Drain plug Vidange / Ablaßschraube

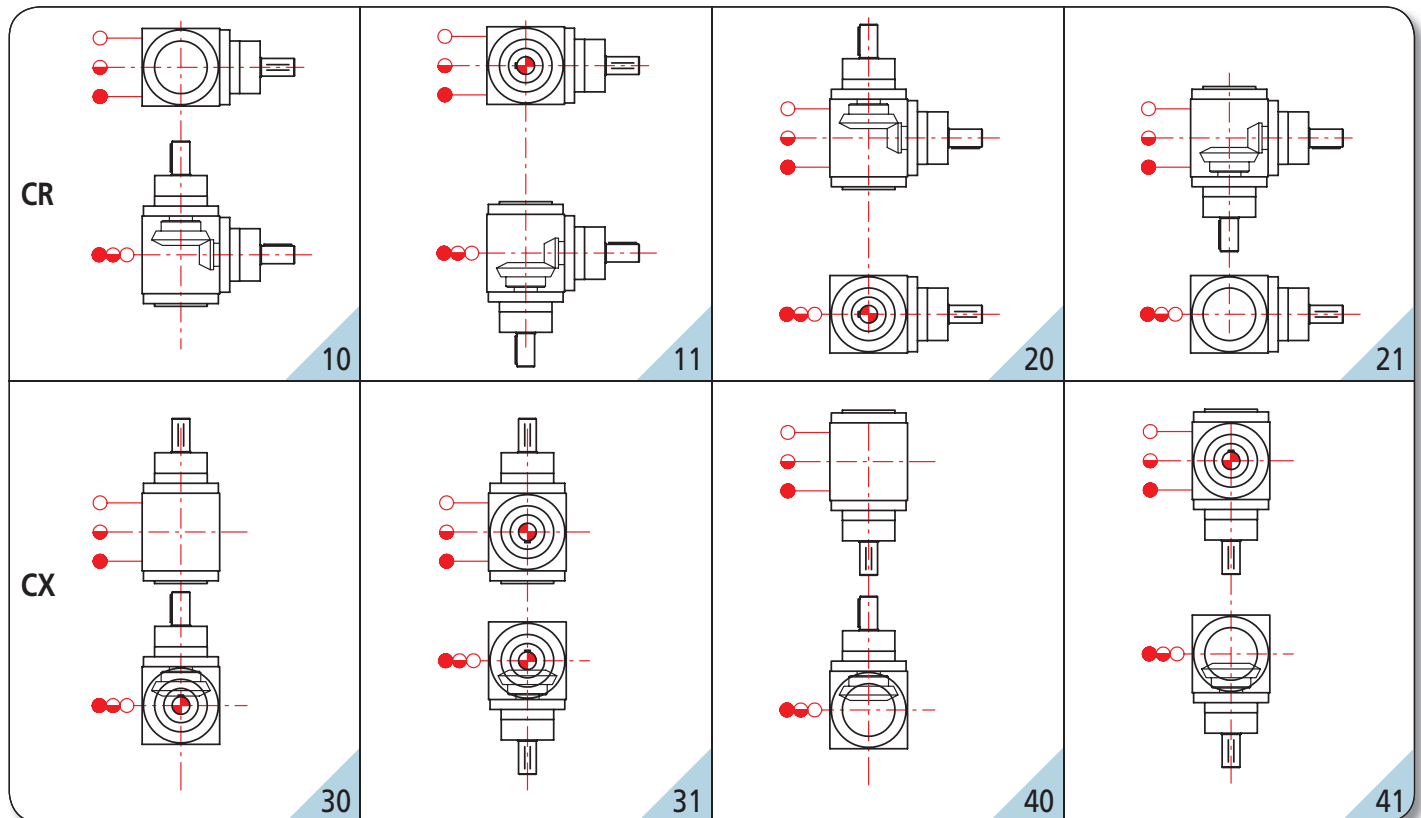

Taglia Size Taille Bautgröße	Rapporto Ratio Rapport Übersetzung	N	O	P	R	S1	S2	C1	C2	T
BG12	1, 2, 3	65	45	M6 ***	M6	M4x8	M4x8	20x4x4	20x4x4	9.5
BG19	1, 2, 3	90	70	M6	M6	M6x12	M6x12	35x6x6	35x6x6	14
	4, 5					M5x10		25x5x5		
BG24	1, 2, 3	110	88	M8	M8	M8x16	M8x16	40x8x7	40x8x7	18
	4, 5					M6x12		35x6x6		
BG32	1, 2, 3	140	110	M10	M10	M10x20	M10x20	50x10x8	50x10x8	18
	4, 5					M8x16		40x8x7		
BG38	1, 2, 3	170	136	M12	M12	M12x24	M12x24	60x10x8	60x10x8	18
	4, 5					M10x20		50x8x7		
BG42	1, 2, 3	200	155	M12	M12	M12x24	M12x24	70x12x8	70x12x8	18
	4, 5					M10x20		50x10x8		
BG55	1, 2, 3	240	190	M14	M14	M14x28	M14x28	100x16x10	100x16x10	23
	4, 5					M12x24		70x12x8		
BG75	1, 2, 3	330	248	M16	M16	M16x32	M16x32	140x20x14	140x20x14	30
	4, 5					M14x28		100x16x10		

\*\*\* Nella grandezza BG12 i fori "P" di interesse "O" sono presenti solamente sulle facce libere.  
 On BG12 size the holes P at centres O are only available on the side.  
 Dans la taille BG12 les trous «P» d'entraxe «O» sont présents seulement sur les côtés libres.  
 Bei der Baugröße BG12 sind die Bohrungen P mit dem Lochabstand O nur auf den Seiten ohne Wellen vorhanden.



## DIMENSIONI D'INGOMBRO / DIMENSIONS / DIMENSIONS D'ENCOMBREMENT / MAßE

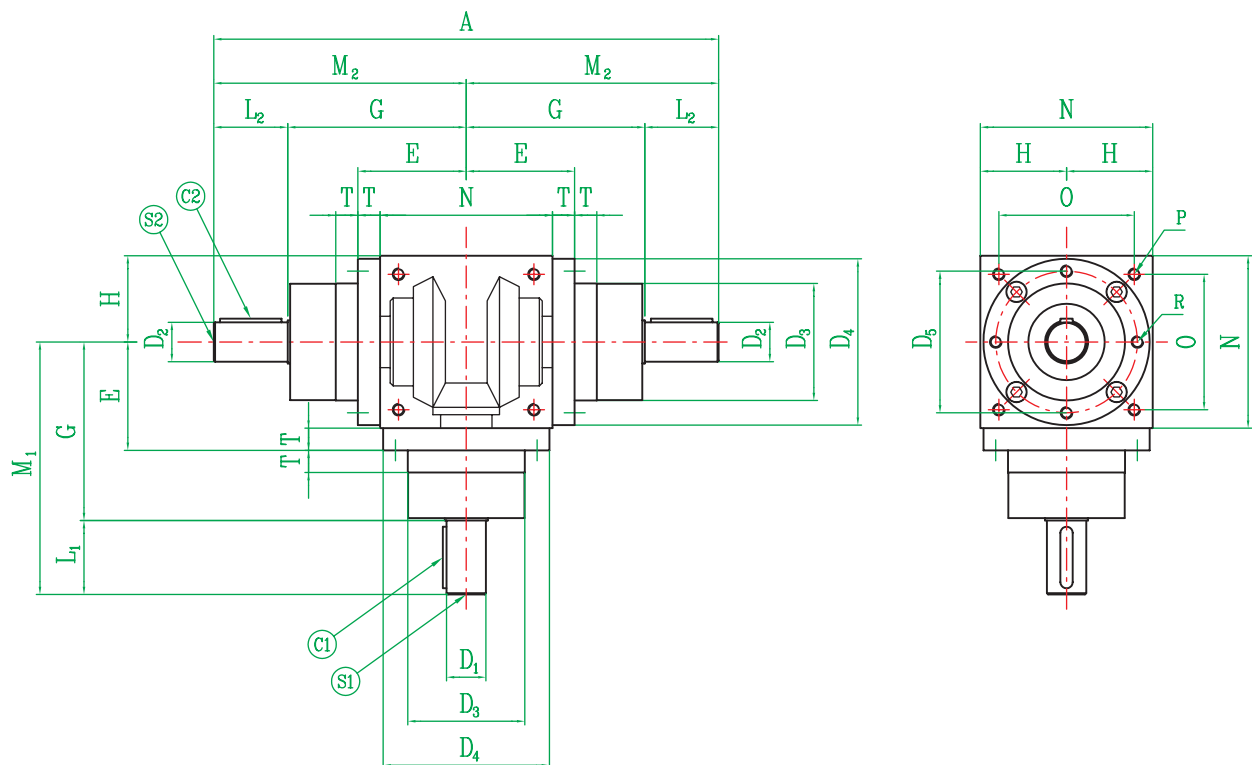

Taglia Size Taille Bautgröße	Rapporto Ratio Rapport Übersetzung	A	D <sub>1</sub>	D <sub>2</sub>	D <sub>3</sub>	D <sub>4</sub>	D <sub>5</sub>	E	G	H	L <sub>1</sub>	L <sub>2</sub>	M <sub>1</sub>	M <sub>2</sub>
BG12	1, 2, 3	200	12 j6	12 j6	44 h7	65 **	54	42	74	32.5	26	26	100	100
BG19	1, 2, 3	280	19 j6	19 j6	60 h7	86 h7	72	59	100	45	40	40	140	140
	4, 5		14 j6								30			
BG24	1, 2, 3	330	24 j6	24 j6	70 h7	105 h7	88	73	115	55	50	50	165	165
	4, 5		19 j6								40			
BG32	1, 2, 3	410	32 j6	32 j6	95 h7	135 h7	115	88	145	70	60	60	205	205
	4, 5		24 j6								50			
BG38	1, 2, 3	480	38 j6	38 j6	120 h7	165 h7	145	103	170	85	70	70	240	240
	4, 5		28 j6								60			
BG42	1, 2, 3	550	42 j6	42 j6	135 h7	190 h7	165	118	195	100	80	80	275	275
	4, 5		32 j6								60			
BG55	1, 2, 3	710	55 j6	55 j6	170 h7	230 h7	205	143	245	120	110	110	355	355
	4, 5		42 j6								80			
BG75	1, 2, 3	1000	75 j6	75 j6	220 *	300 h7 *	--	195	350	165	150	150	500	500
	4, 5		55 j6		110	460								

\* Nel caso del rinvio angolare BG75 se occorre centrarsi su questo diametro chiedere informazioni al nostro ufficio tecnico / For spiral bevel gearbox BG75, please request further information to our engineering dept. to be able to centre on this diameter / Dans le cas du renvoi d'angle BG75, s'il faut que le centrage se produise sur ce diamètre, faire appel à notre service d'assistance technique / Sollte es im Falle des Winkel-Vorgeleges BG75 erforderlich sein, sich auf diesen Durchmesser zu zentrieren, sind bei unserer technischen Abteilung Informationen einzuholen.



\*\* Il diametro non è in tolleranza / Diameter is out of tolerance / Le diamètre n'est pas en tolérance / Der Durchmesser ist nicht in Toleranz.

**POSIZIONI DI MONTAGGIO / MOUNTING POSITION**  
**POSITIONS DE MONTAGE / EINBAULAGEN - KEGELRADGETRIEBE**

Schema superiore: Vista dal fianco - Schema inferiore: Vista dall'alto  
 Top diagram: Side view - Bottom diagram: Top view  
 Schéma supérieur: Vu de côté - Schéma inférieur: Vue d'en haut  
 Seitenansicht - Draufsicht

	Sfiato / Breather plug Évent / Einfüll Entlüftungsstopfen
	Livello / Level plug Niveau / Ölstandanzeige
	Scarico / Drain plug Vidange / Ablasschraube

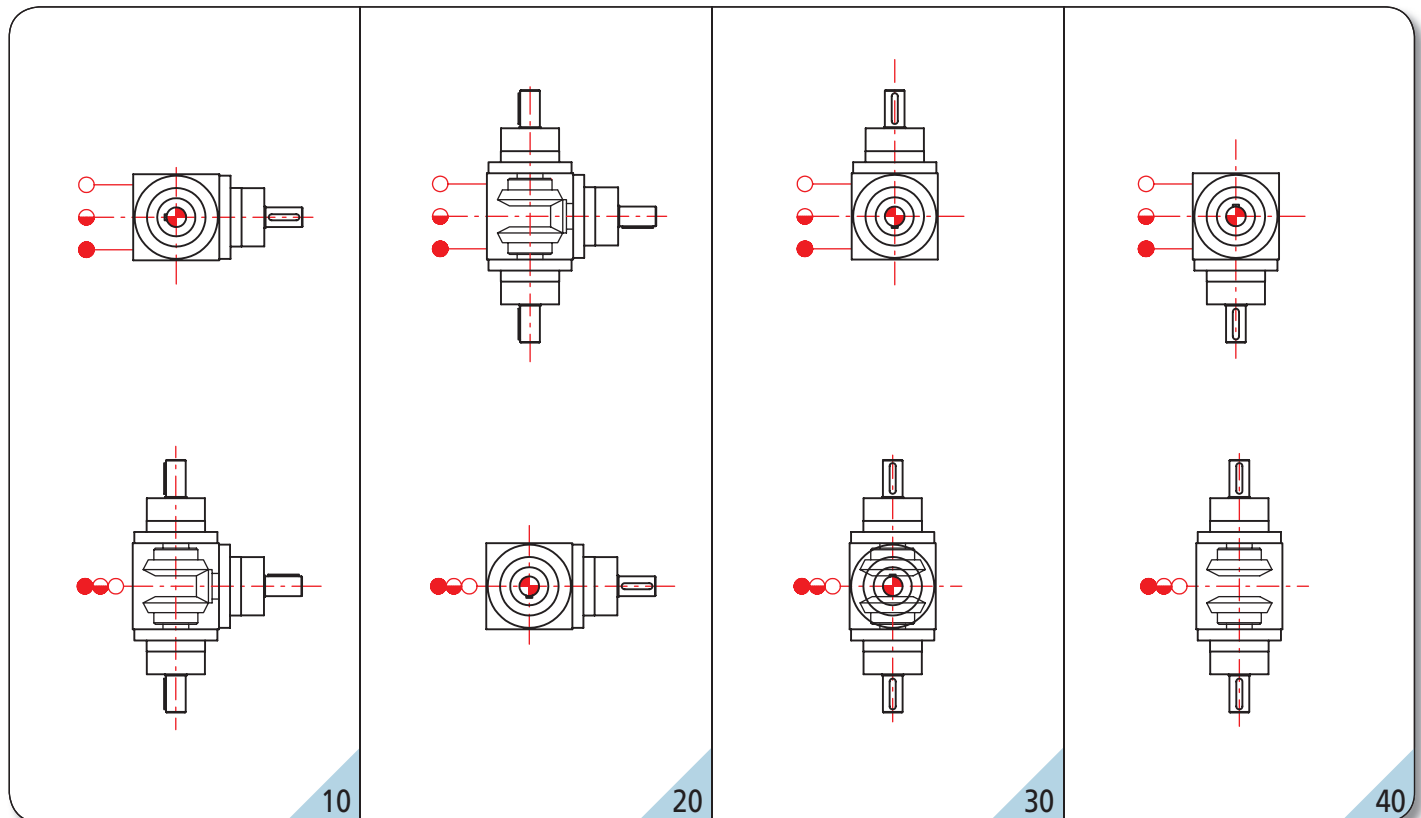

Taglia Size Taille Bautgröße	Rapporto Ratio Rapport Übersetzung	N	O	P	R	S1	S2	C1	C2	T
BG12	1, 2, 3	65	45	M6 ***	M6	M4x8	M4x8	20x4x4	20x4x4	9.5
BG19	1, 2, 3	90	70	M6	M6	M6x12	M6x12	35x6x6	35x6x6	14
	4, 5					M5x10		25x5x5		
BG24	1, 2, 3	110	88	M8	M8	M8x16	M8x16	40x8x7	40x8x7	18
	4, 5					M6x12		35x6x6		
BG32	1, 2, 3	140	110	M10	M10	M10x20	M10x20	50x10x8	50x10x8	18
	4, 5					M8x16		40x8x7		
BG38	1, 2, 3	170	136	M12	M12	M12x24	M12x24	60x10x8	60x10x8	18
	4, 5					M10x20		50x8x7		
BG42	1, 2, 3	200	155	M12	M12	M12x24	M12x24	70x12x8	70x12x8	18
	4, 5					M10x20		50x10x8		
BG55	1, 2, 3	240	190	M14	M14	M14x28	M14x28	100x16x10	100x16x10	23
	4, 5					M12x24		70x12x8		
BG75	1, 2, 3	330	248	M16	M16	M16x32	M16x32	140x20x14	140x20x14	30
	4, 5					M14x28		100x16x10		

\*\*\* Nella grandezza BG12 i fori "P" di interasse "O" sono presenti solamente sulle facce libere.  
 On BG12 size the holes P at centres O are only available on the side.  
 Dans la taille BG12 les trous «P» d'entraxe «O» sont présents seulement sur les côtés libres.  
 Bei der Baugröße BG12 sind die Bohrungen P mit dem Lochabstand O nur auf den Seiten ohne Wellen vorhanden.



DIMENSIONI D'INGOMBRO / DIMENSIONS / DIMENSIONS D'ENCOMBREMENT / MAßE

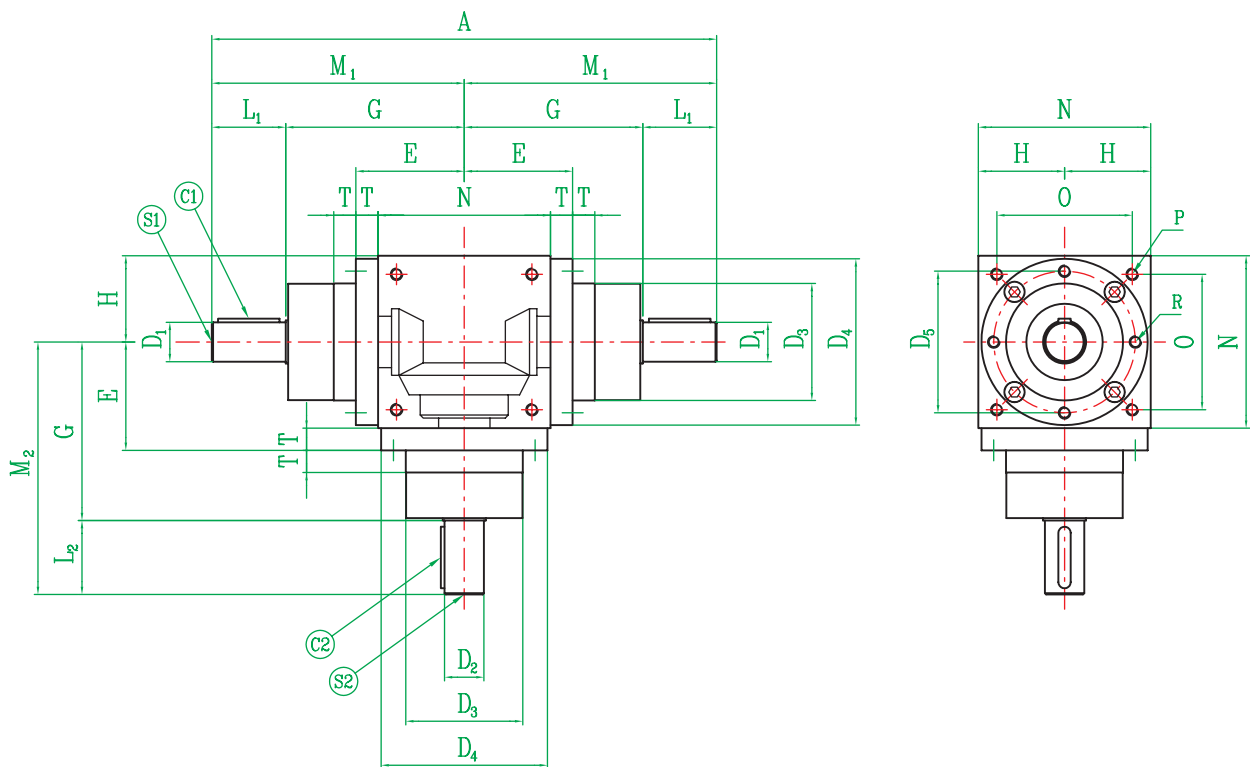

Taglia Size Taille Bautgröße	Rapporto Ratio Rapport Übersetzung	A	D <sub>1</sub>	D <sub>2</sub>	D <sub>3</sub>	D <sub>4</sub>	D <sub>5</sub>	E	G	H	L <sub>1</sub>	L <sub>2</sub>	M <sub>1</sub>	M <sub>2</sub>
BG12	1, 2, 3	200	12 j6	12 j6	44 h7	65 **	54	42	74	32.5	26	26	100	100
BG19	1, 2, 3	280	19 j6	19 j6	60 h7	86 h7	72	59	100	45	40	40	140	140
	4, 5	260	14 j6								30		130	
BG24	1, 2, 3	330	24 j6	24 j6	70 h7	105 h7	88	73	115	55	50	50	165	165
	4, 5	310	19 j6								40		155	
BG32	1, 2, 3	410	32 j6	32 j6	95 h7	135 h7	115	88	145	70	60	60	205	205
	4, 5	390	24 j6								50		195	
BG38	1, 2, 3	480	38 j6	38 j6	120 h7	165 h7	145	103	170	85	70	70	240	240
	4, 5	460	28 j6								60		230	
BG42	1, 2, 3	550	42 j6	42 j6	135 h7	190 h7	165	118	195	100	80	80	275	275
	4, 5	510	32 j6								60		255	
BG55	1, 2, 3	710	55 j6	55 j6	170 h7	230 h7	205	143	245	120	110	110	355	355
	4, 5	650	42 j6								80		325	
BG75	1, 2, 3	1000	75 j6	75 j6	220 *	300 h7 *	--	195	350	165	150	150	500	500
	4, 5	920	55 j6		110	460								

\* Nel caso del rinvio angolare BG75 se occorre centrarsi su questo diametro chiedere informazioni al nostro ufficio tecnico / For spiral bevel gearbox BG75, please request further information to our engineering dept. to be able to centre on this diameter / Dans le cas du renvoi d'angle BG75, s'il faut que le centrage se produise sur ce diamètre, faire appel à notre service d'assistance technique / Sollte es im Falle des Winkel-Vorgeleges BG75 erforderlich sein, sich auf diesen Durchmesser zu zentrieren, sind bei unserer technischen Abteilung Informationen einzuholen.





\*\* Il diametro non è in tolleranza / Diameter is out of tolerance / Le diamètre n'est pas en tolérance / Der Durchmesser ist nicht in Toleranz.



**POSIZIONI DI MONTAGGIO / MOUNTING POSITION**  
**POSITIONS DE MONTAGE / EINBAULAGEN - KEGELRADGETRIEBE**

Schema superiore: Vista dal fianco - Schema inferiore: Vista dall'alto  
 Top diagram: Side view - Bottom diagram: Top view  
 Schéma supérieur: Vu de côté - Schéma inférieur: Vue d'en haut  
 Seitenansicht - Draufsicht

	Sfiato / Breather plug Évent / Einfüll Entlüftungsstopfen
	Livello / Level plug Niveau / Ölstandanzeige
	Scarico / Drain plug Vidange / Ablasschraube

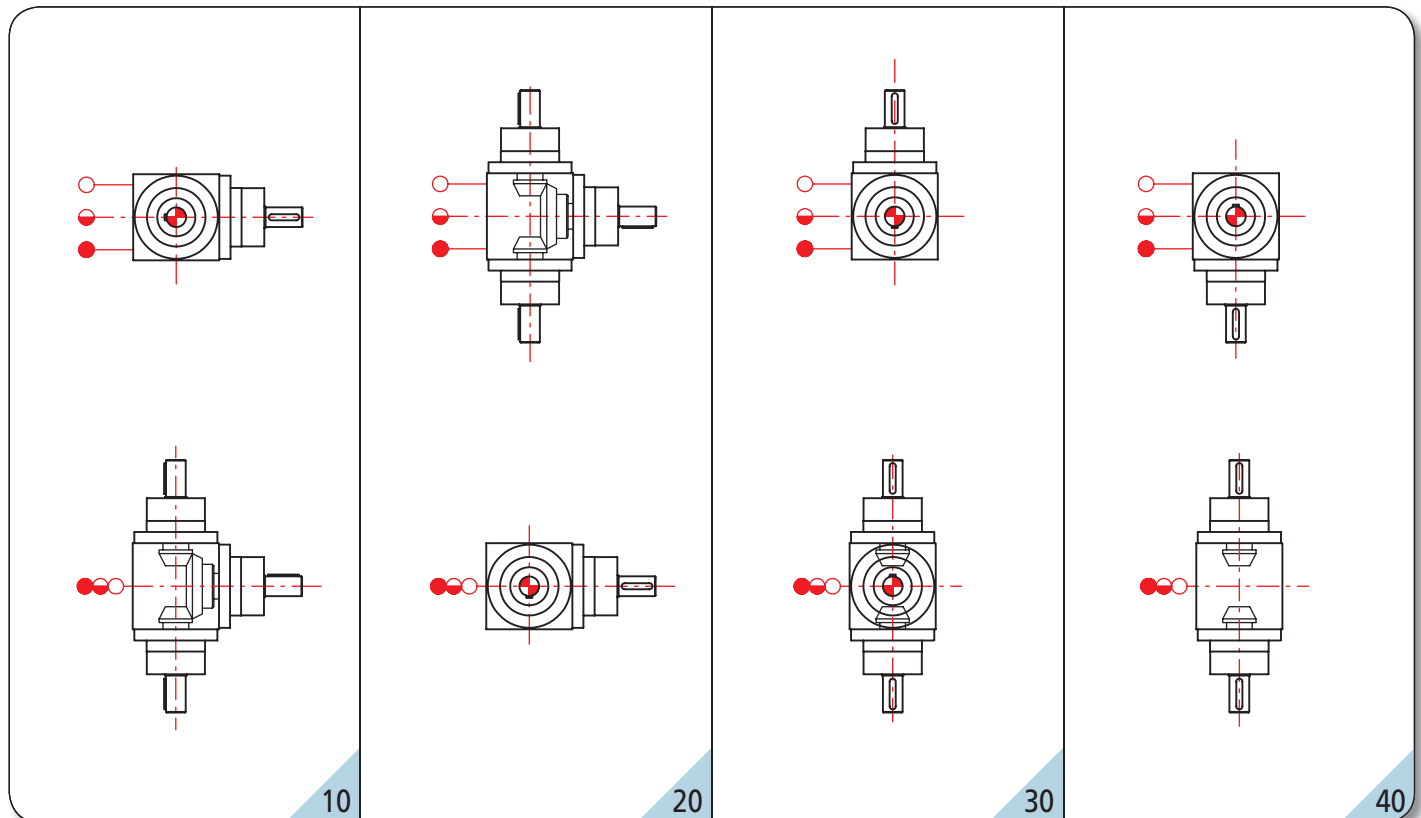

Taglia Size Taille Bautgröße	Rapporto Ratio Rapport Übersetzung	N	O	P	R	S1	S2	C1	C2	T
BG12	1, 2, 3	65	45	M6 ***	M6	M4x8	M4x8	20x4x4	20x4x4	9.5
BG19	1, 2, 3	90	70	M6	M6	M6x12	M6x12	35x6x6	35x6x6	14
	4, 5					M5x10		25x5x5		
BG24	1, 2, 3	110	88	M8	M8	M8x16	M8x16	40x8x7	40x8x7	18
	4, 5					M6x12		35x6x6		
BG32	1, 2, 3	140	110	M10	M10	M10x20	M10x20	50x10x8	50x10x8	18
	4, 5					M8x16		40x8x7		
BG38	1, 2, 3	170	136	M12	M12	M12x24	M12x24	60x10x8	60x10x8	18
	4, 5					M10x20		50x8x7		
BG42	1, 2, 3	200	155	M12	M12	M12x24	M12x24	70x12x8	70x12x8	18
	4, 5					M10x20		50x10x8		
BG55	1, 2, 3	240	190	M14	M14	M14x28	M14x28	100x16x10	100x16x10	23
	4, 5					M12x24		70x12x8		
BG75	1, 2, 3	330	248	M16	M16	M16x32	M16x32	140x20x14	140x20x14	30
	4, 5					M14x28		100x16x10		

\*\*\* Nella grandezza BG12 i fori "P" di interasse "O" sono presenti solamente sulle facce libere.  
 On BG12 size the holes P at centres O are only available on the side.  
 Dans la taille BG12 les trous «P» d'entraxe «O» sont présents seulement sur les côtés libres.  
 Bei der Baugröße BG12 sind die Bohrungen P mit dem Lochabstand O nur auf den Seiten ohne Wellen vorhanden.



 **RINVIO ANGOLARE  
CON FLANGIATURA  
MOTORE**

 **SPIRAL BEVEL  
GEARBOX WITH  
IEC MOTOR FLANGE  
ADAPTOR**

 **RENVOI D'ANGLE  
AVEC BRIDAGE  
MOTEUR**

 **KEGELRODGETRIEBE  
MIT MOTORFLANSCH  
- ADAPTER**

**DIMENSIONI D'INGOMBRO / DIMENSIONS / DIMENSIONS D'ENCOMBREMENT / MAßE**

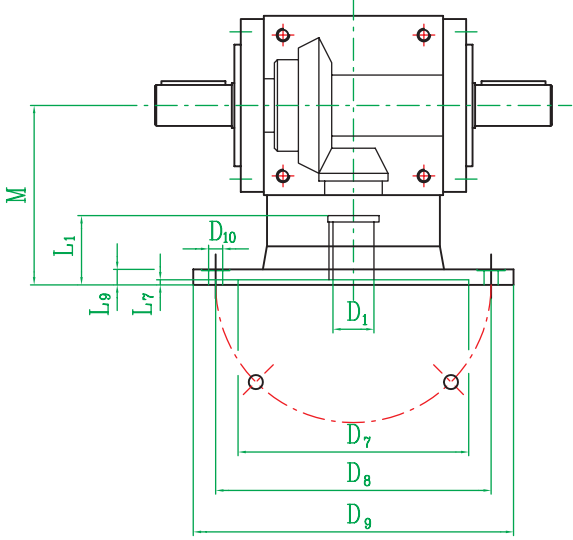
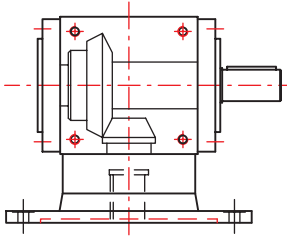
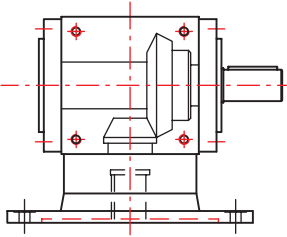
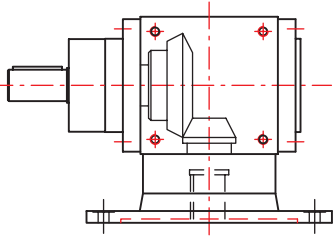
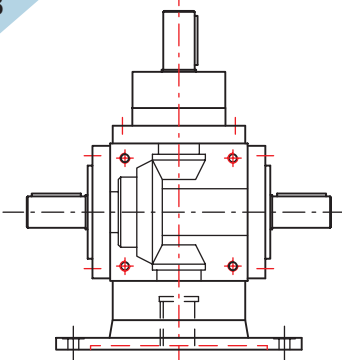
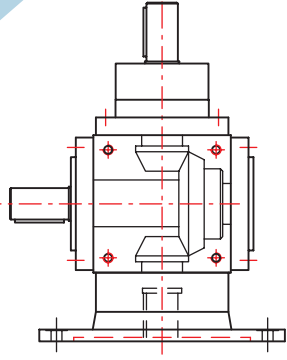
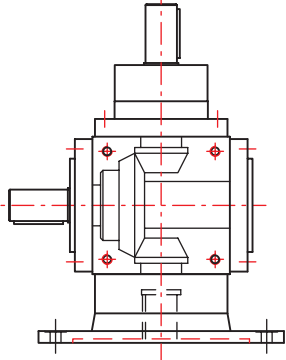
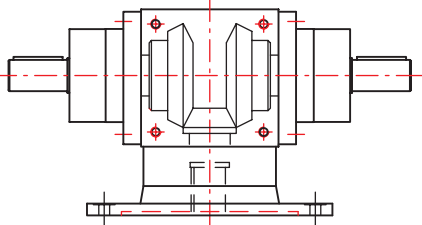
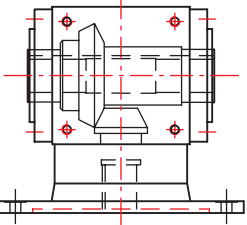
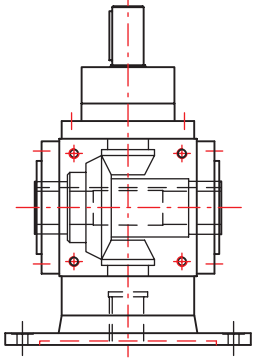
<p><b>MA</b></p> 		
<p><b>MAS</b></p> 	<p><b>MAD</b></p> 	<p><b>MC</b></p> 
<p><b>MB</b></p> 	<p><b>MBS</b></p> 	<p><b>MBD</b></p> 
<p><b>MDR</b></p> 	<p><b>MAH</b></p> 	<p><b>MBH</b></p> 



 Le quote non indicate e le posizioni di montaggio possono essere desunte dalle tabelle relative alle singole forme costruttive (es. MA: forma A).

 The dimensions that are not indicated and the mounting position for oil lubrication can be taken from the tables of standard types (ex. MA: type A).

 Les valeurs qui ne sont pas indiquées et les positions de montage peuvent être tirées des tableaux relatifs aux formes de construction individuelles (ex. Ma : forme A).

 Die Abmessungen, die hier nicht angegeben wurden, sowie die Einbaulagen können den Tabellen für die einzelnen Konstruktionsausführungen entnommen werden.

Taglia Size Taille Bautröße	Rapporto Ratio Rapport Übersetzung	Grandezza motore Motor frame size Taille moteur Motor Größe / B5	D <sub>1</sub>	D <sub>7</sub>	D <sub>8</sub>	D <sub>9</sub>	D <sub>10</sub>	L <sub>1</sub>	L <sub>7</sub>	L <sub>9</sub>	M
BG12	1, 2, 3	63 B5	11	95	115	140	M8	26	4	10	90
		63 B14	11	60	75	90	Ø 6	38	4	10	90
		71 B14	14	70	85	105	Ø 7	35	4	10	90
BG19	1, 2, 3	63 B14	11	60	75	90	Ø 5.5	28	4	12	90
		71 B5	14	110	130	160	M8	30	4	12	90
		71 B14	14	70	85	105	Ø 6.5	32	4	15	90
	4, 5	80 B5	19	130	165	200	M10	40	5	12	94
		80 B14	19	80	100	120	Ø 6.5	43	4	12	94
BG24	1, 2, 3	63 B5	11	95	115	140	M8	28	4	12	120
		71 B5	14	110	130	160	M8	30	4	12	120
		71 B14	14	70	85	105	Ø 6.5	42	4	23	120
	4, 5	80 B5	19	130	165	200	M10	40	5	12	120
		80 B14	19	80	100	120	Ø 6.5	44	4	23	120
		90 B5	24	130	165	200	M10	50	5	12	120
		90 B14	24	95	115	140	Ø 8.5	52	4	12	120
BG32	1, 2, 3	71 B5	14	110	130	160	M8	50	5	20	140
		80 B5	19	130	165	200	M10	40	5	15	140
		90 B5	24	130	165	200	M10	50	5	15	140
	4, 5	90 B14	24	95	115	140	Ø 8.5	54	4	30	140
		112 B5	28	180	215	250	M12	60	5	15	140
		112 B14	28	110	130	160	Ø 8.5	63	5	20	140
BG38	1, 2, 3	90 B5	24	130	165	200	M10	50	5	20	155
		112 B5	28	180	215	250	M12	60	5	20	155
		132 B5	38	230	265	300	M12	80	5	20	175
		132 B14	38	130	165	200	Ø 11	80	5	20	175
	4, 5	90 B5	24	130	165	200	M10	50	5	20	155
		112 B5	28	180	215	250	M12	60	5	20	155
		132 B5	38	230	265	300	M12	80	5	20	200
132 B14	38	130	165	200	Ø 11	80	5	20	200		
BG42	1, 2	112 B5	28	180	215	250	M12	60	5	20	200
		132 B5	38	230	265	300	M12	80	5	20	200
		160 B5	42	250	300	350	M16	110	6	20	200
	3	112 B5	28	180	215	250	M12	60	5	20	200
		132 B5	38	230	265	300	M12	80	5	20	200
		160 B5	42	250	300	350	M16	110	6	20	230
	4, 5	112 B5	28	180	215	250	M12	60	5	20	200
		132 B5	38	230	265	300	M12	82	6	20	200
		160 B5	42	250	300	350	M16	112	6	20	230
BG55	1, 2, 3	112 B5	28	180	215	250	M12	60	5	25	220
		132 B5	38	230	265	300	M12	80	5	25	220
		160 B5	42	250	300	350	M16	110	6	30	235
	4, 5	180 B5	48	250	300	350	M16	112	6	30	235
		112 B5	28	180	215	250	M12	60	5	25	220
		132 B5	38	230	265	300	M12	80	5	25	220
BG75	1, 2, 3 4, 5	160 B5	42	250	300	350	M16	121	6	25	375
		180 B5	48	250	300	350	M16	121	6	25	375
		200 B5	48	300	350	400	M16	125	6	30	375



## RINVII ANGOLARI MULTIALBERO

 Il progetto modulare consente il montaggio di alberi supplementari per tutti i rapporti, tranne che per il rapporto 1/1.

Per l'indicazione della forma costruttiva occorre attenersi alla definizione (A, B, C, D, E, F) delle facce e dei relativi alberi per poter individuare i piani di fissaggio e posizione dei tappi nel caso di lubrificazione ad OLIO.

## MULTISHAFT BEVEL GEARBOXES

 Modular design permits supplementary gears and shafts for all ratio except 1:1. It is important to specify exact shaft outputs (A, B, C, D, E or F) and mounting position to ensure that mounting holes and oil breather, level and drain plugs are in the correct position.

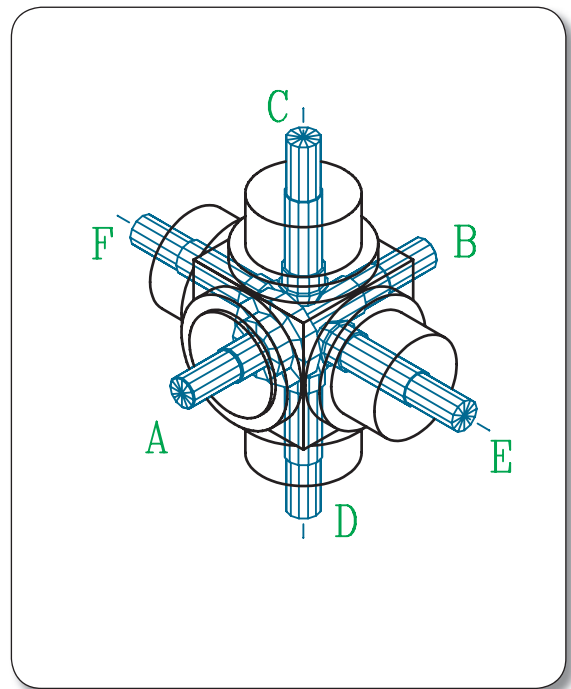

## RENVOIS D'ANGLE MULTI-ARBRE

 Le projet modulaire permet le montage des arbres supplémentaires pour tous les rapports, sauf le rapport 1/1.

Pour l'indication de la forme de construction il faut se conformer à la définition (A, B, C, D, E, F) des côtés et des arbres relatifs pour pouvoir identifier les plans de fixation et position des bouchons dans le cas de lubrification à l'HUILE.

## KEGELRADGETRIEBE MIT MEHRFACHWELLEN

 Das Modulaufbau ermöglicht auch die Montage zusätzlicher Wellen für alle Übersetzungen, mit Ausnahme der 1:1 Übersetzung.

Bei Bestellung sind die Angaben A, B, C, D, E, F unbedingt erforderlich, um Befestigungsebenen und Lage der Stopfen bei Ölschmierung festzulegen.

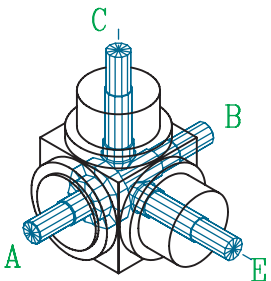
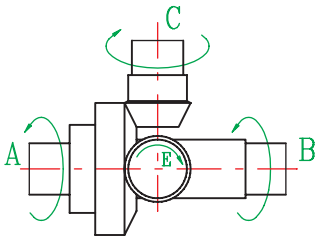
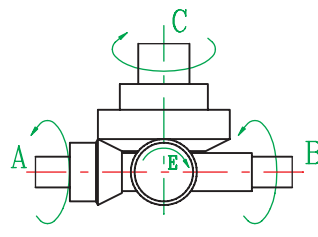
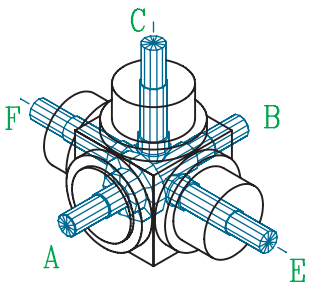
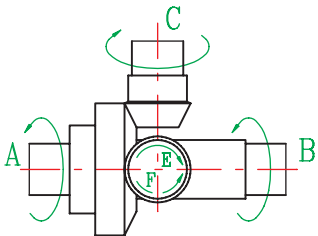
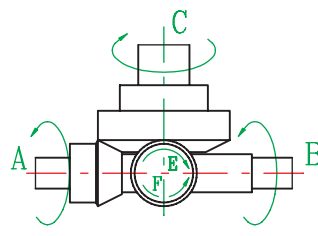
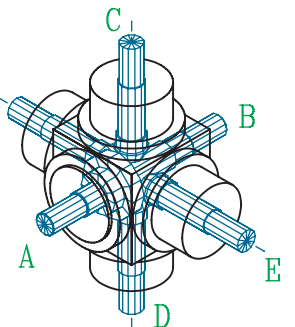
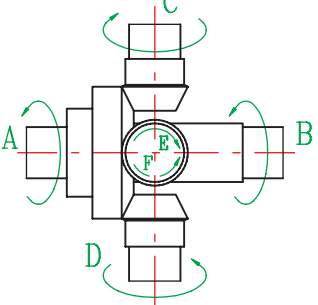
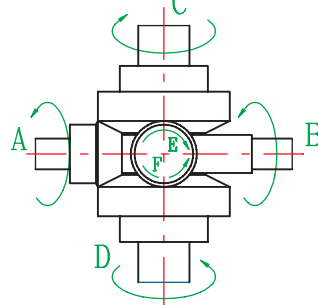
Denominazione <i>Designation</i> Dénomination Bezeichnung	Combinazioni possibili <i>Possible combinations</i> Combinaisons possibles Mögliche Kombinationen	Posizione ingranaggi e sensi di rotazione / <i>Gear positions and rotations</i> Position engrenages et sens de rotation / <i>Anordnungen und Drehrichtungen</i>	
		Riduttori / <i>Speed reducers</i> Réducteurs / <i>Untersetzungsgetriebe</i>	Moltiplicatori / <i>Speed increasers</i> Multiplificateurs / <i>Übersetzungsgetriebe</i>
A 90			
A 180			
A 270			

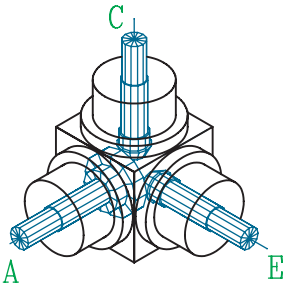
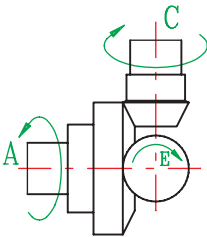
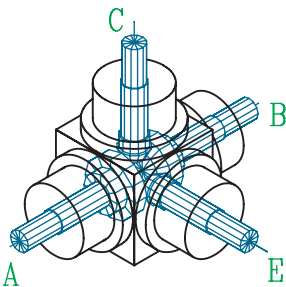
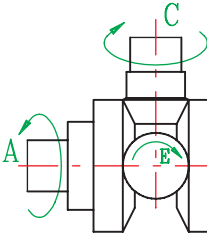
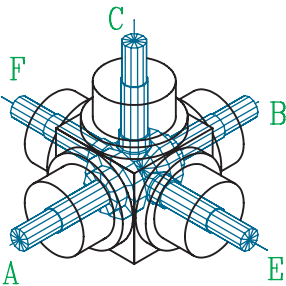
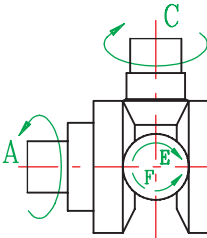
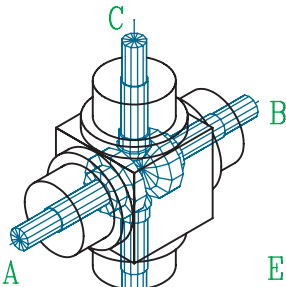
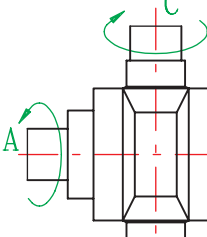
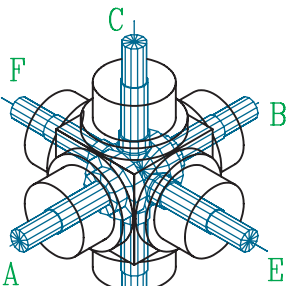
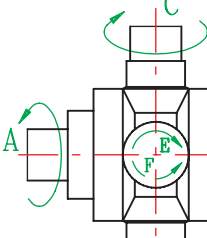

Denominazione <i>Designation</i> Dénomination Bezeichnung	Combinazioni possibili <i>Possible combinations</i> Combinaisons possibles Mögliche Kombinationen	Posizione ingranaggi e sensi di rotazione / <i>Gear positions and rotations</i> Position engrenages et sens de rotation / <i>Anordnungen und Drehrichtungen</i>	
		Riduttori / <i>Speed reducers</i> Réducteurs / <i>Untersetzungsgetriebe</i>	Moltiplicatori / <i>Speed increasers</i> Multiplicateurs / <i>Übersetzungsgetriebe</i>
AS 90			
AS 180			
AS 270			
AD 90			
AD 180			
AD 270			

Denominazione <i>Designation</i> Dénomination Bezeichnung	Combinazioni possibili <i>Possible combinations</i> Combinaisons possibles Mögliche Kombinationen	Posizione ingranaggi e sensi di rotazione <i>Gear positions and rotations</i> Position engrenages et sens de rotation Anordnungen und Drehrichtungen
C 90		
D 90		
DB 90		
DB		
DB 180		

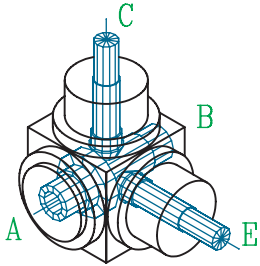
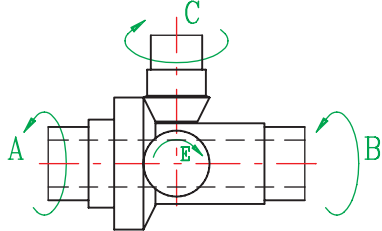
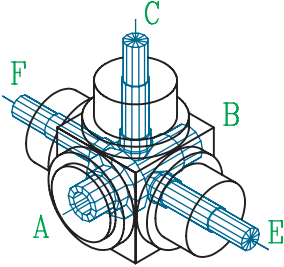
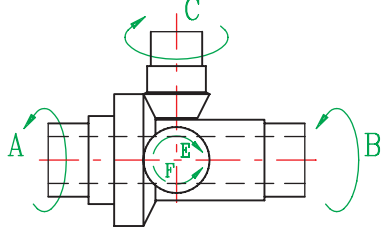
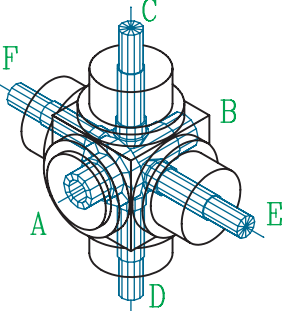
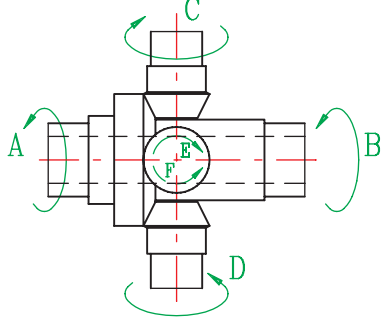
Denominazione <i>Designation</i> Dénomination Bezeichnung	Combinazioni possibili <i>Possible combinations</i> Combinaisons possibles Mögliche Kombinationen	Posizione ingranaggi e sensi di rotazione <i>Gear positions and rotations</i> Position engrenages et sens de rotation Anordnungen und Drehrichtungen
AH 90		
AH 180		
AH 270		

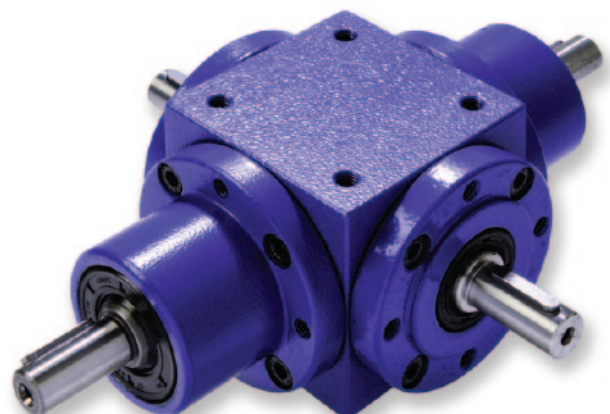
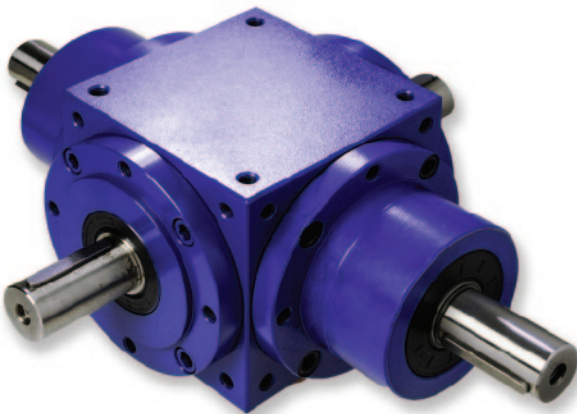

## INVERTITORI MECCANICI

### INVERTITORI ORTOGONALI

 Sono costituiti da una terna di ingranaggi conici con rapporto di trasmissione 1/1 e 1/2 (solo in riduzione).

Invertono il senso di rotazione dell'albero passante, fermo restando quello dell'albero di entrata o viceversa, disponendo nella posizione intermedia di una funzione di "folle".

La manovra si effettua manualmente agendo sulla leva di comando, a macchina ferma.

La posizione di innesto è normalmente indifferente, ed in questo caso l'invertitore viene denominato FP (Full Position). A richiesta vengono fabbricati con posizione d'innesto obbligata ed univoca, tali vengono denominati SP (Single Position).

Sono costruiti nelle grandezze 32 - 42 - 55.

Le prestazioni corrispondono ai valori di coppia e potenza riportati a pag. 5-6, diminuiti del 30%.

Le dimensioni di ingombro e le posizioni di montaggio sono rispettivamente identiche a quelle delle forme A (pag. 20-21) e DR (pag. 50-51).

## REVERSING SPIRAL BEVEL GEARBOXES

### TIPO IO 90 DEGREE REVERSING SPIRAL BEVEL GEARBOXES

### TYPE IO

 90 degree reversing spiral bevel gearboxes are available with ratio 1:1 and 1:2 only.

By moving the control lever from fully engaged through neutral to fully engaged in the apposite direction the 90 degree shaft will change rotation. Operation of the lever, which is normally carried out by hand, may only be done when the unit is stationary.

Engaging position is usually indifferent, and reversing spiral bevel gearbox is called FP (Full Position).

On request may be supplied with option SP (Single Position) and is possible only one engaging position on 360 degrees.

Reversing bevel gearboxes are produced in sizes BG32, BG42, BG55 only.

Selection corresponds to input kW and output torque as pages 5-6 reduced by 30%.

Dimensions and mounting positions are the same as type A (pages 20-21) and type DR (pages 50-51).

### FORMA A / TYPE A / FORME A / FORM A

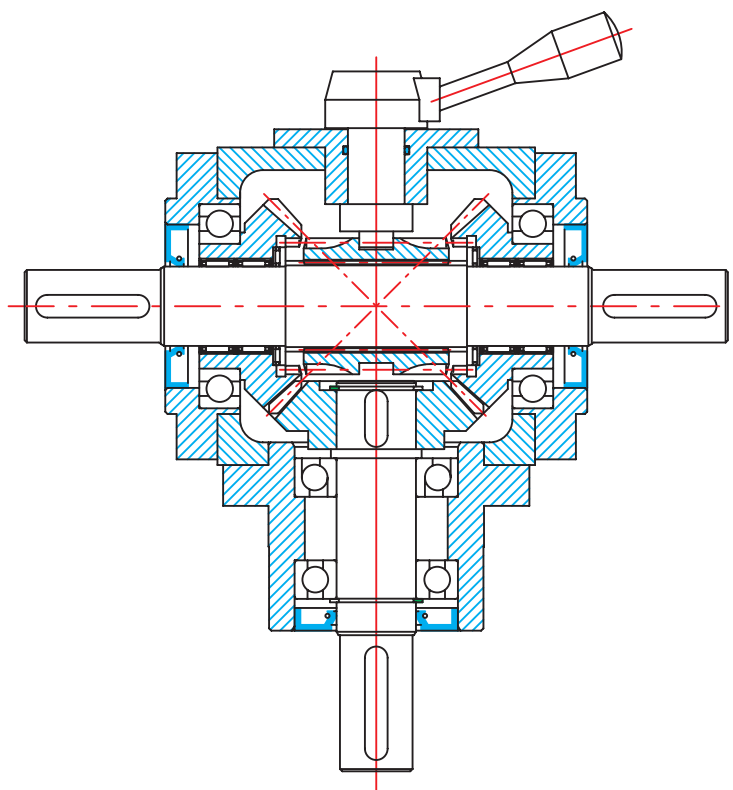



## VARIATEURS MÉCANIQUES

## MECHANISCHE WENDEGETRIEBE

### VARIATEURS ORTHOGONAUX

### TYPE IO

### RECHTWINKLIGE WENDEGETRIEBE

### TYP IO

 Ils sont composés d'un train d'engrenages coniques avec rapport de transmission 1/1 et 1/2 (seulement en réduction). Ils inversent le sens de rotation de l'arbre traversant, indépendamment du sens de l'arbre d'entrée et vice versa, ayant dans la position intermédiaire une fonction de «point mort».

La manœuvre s'effectue manuellement en agissant sur le levier de commande, machine à l'arrêt.

La position d'embrayage est normalement indifférente et dans ce cas le variateur est dénommé FP (Full Position). Sur demande ils sont fabriqués avec position d'embrayage obligatoire et univoque, ils sont dénommés SP (Single Position).

Ils sont construits dans les tailles 32 - 42 - 55.

Les prestations correspondent aux valeurs de couple et puissance indiquées à page 5-6, réduites de 30%.

Les dimensions d'encombrement et les positions de montage sont respectivement identiques à celles des formes A (page 20-21) et DR (page 50-51).

 Diese bestehen aus drei Kegelelradern mit einem Verhältnis 1:1 und 1:2 (nur Untersetzung).

Sie invertieren die Rotationsrichtung der Durchgangswelle. In der Zwischenstellung ist eine "Leerlauf" Funktion zur Verfügung:

- Die Schaltung erfolgt manuell durch Betätigen des Steuerhebels bei Maschinenstillstand. Die Einkuppelposition ist normalerweise indifferent und in diesem Fall hat das Wendegetriebe die Bezeichnung FP.
- Auf Anfrage werden diese auch mit Zwangskupplungsposition hergestellt. In diesem Fall erhalten sie die Bezeichnung SP.
- Sie werden in den Größen 32 - 42 - 55 hergestellt.
- Die Leistungen entsprechen den Werten der Übersetzung und Leistung, wie auf Seite 5-6, abzüglich 30%.
- Die Maße der Grundflächen und die Montagepositionen entsprechen exakt denen der FORM A (Seite 20-21) und DR (Seite 50-51).

### FORMA D / TYPE D / FORME D / FORM D

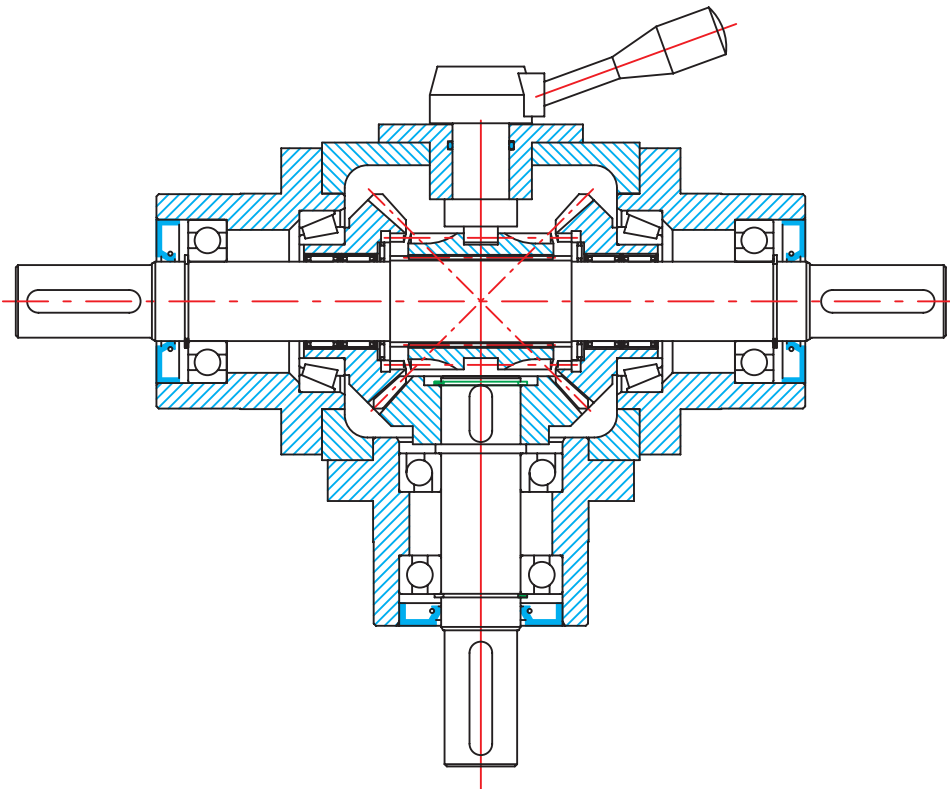

## RINVII ORTOGONALI CON DISINNESTO

 Sono costituiti da una coppia di ingranaggi conici con rapporto di trasmissione 1/1, 2/1 e 3/1 (solo in riduzione).

Permettono, mantenendo inalterata la rotazione dell'albero passante, di escludere quella dell'albero di uscita, o viceversa.

Sono costruiti nelle grandezze 32 - 42 - 55.

Le prestazioni corrispondono ai valori di coppia e potenza riportati a pag. 5-6, diminuiti del 15%.

Le dimensioni di ingombro e le posizioni di montaggio, sono rispettivamente identiche a quelle delle forme A (pag. 20-21) e DR (pag. 50-51).

## TIPO DO **DISENGAGING SPIRAL BEVEL GEARBOXES**

**TTPE DO**

 Disengaging spiral bevel gearboxes are manufactured in ratio 1:1, 1:2, 1:3 only.

Operation of the lever disengages the 90 degree shaft.

This is normally carried out by hand and may only take place when the unit is stationary.

Disengaging spiral bevel gearboxes are produced in sizes BG32, BG42, BG55 only.

Selection corresponds to input kW and output torque as pages 5-6 reduced by 15%.

Dimensions and mounting positions are the same as type A (pages 20-21) and type DR (pages 50-51).

FORMA A / TYPE A / FORME A / FORM A

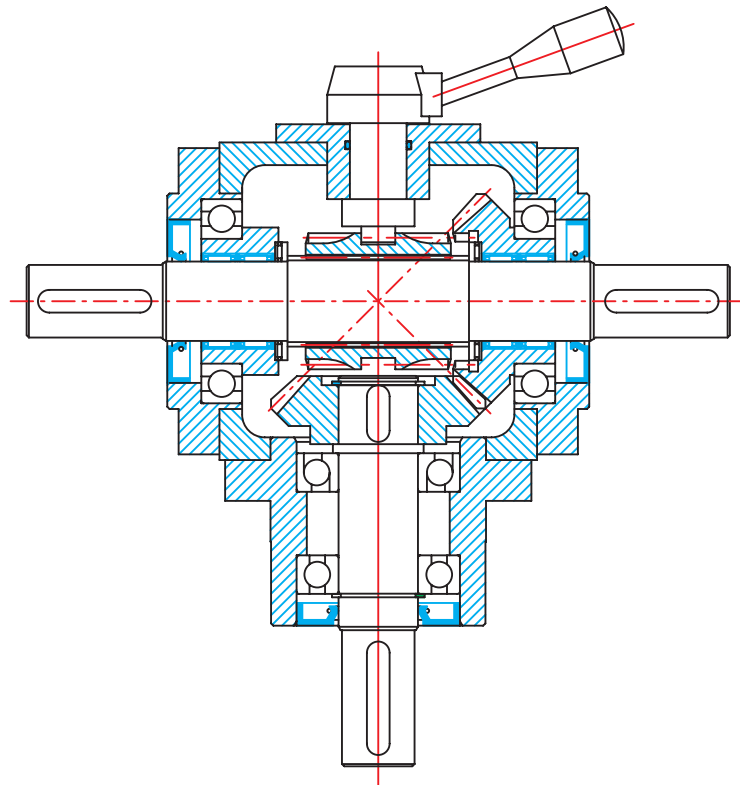

## RENOIS ORTHOGONAUX AVEC DÉBRAYAGES

 Ils se composent d'un couple d'engrenages coniques avec rapport de transmission 1/1, 2/1 et 3/1 (seulement en réduction). Ils permettent, en maintenant la rotation inaltérée de l'arbre traversant, d'exclure celle de l'arbre de sortie ou vice versa.

Ils sont construits dans les tailles suivantes 32 - 42 - 55

Les prestations correspondent aux valeurs de couple et puissance indiquées aux pages 5-6, diminuées de 15%.

Les dimensions d'encombrement et les positions de montage, sont respectivement identiques à celles des formes A (pages 20-21) et DR (pages 50-51).

## TYPE DO

## KEGELRADGETRIEBE MIT AUSKUPPLUNG

## TYP DO

 Diese bestehen aus einem Kegelradpaar mit einem Kegelradpaar mit einem Verhältnis 1:1, 1:2 und 1:3. Sie ermöglichen bei gleichbleibender Rotation der Durchgangswelle das Auskuppeln der Ausgangswelle oder umgekehrt.

- Die Schaltung erfolgt manuell durch Betätigen des Steuerhebels bei Maschinenstillstand.

- Sie werden in den Größen 32 - 42 - 55 hergestellt.

- Die Leistungen entsprechen den Werten Übersetzung und Leistung, wie auf Seite 5-6 dargestellt, abzüglich 15%.

- Die Ausmaße der Grundflächen und die Montagepositionen entsprechen exakt denen der FORM A (Seite 20-21) und DR (Seite 50-51).

### FORMA D / TYPE D / FORME D / FORM D

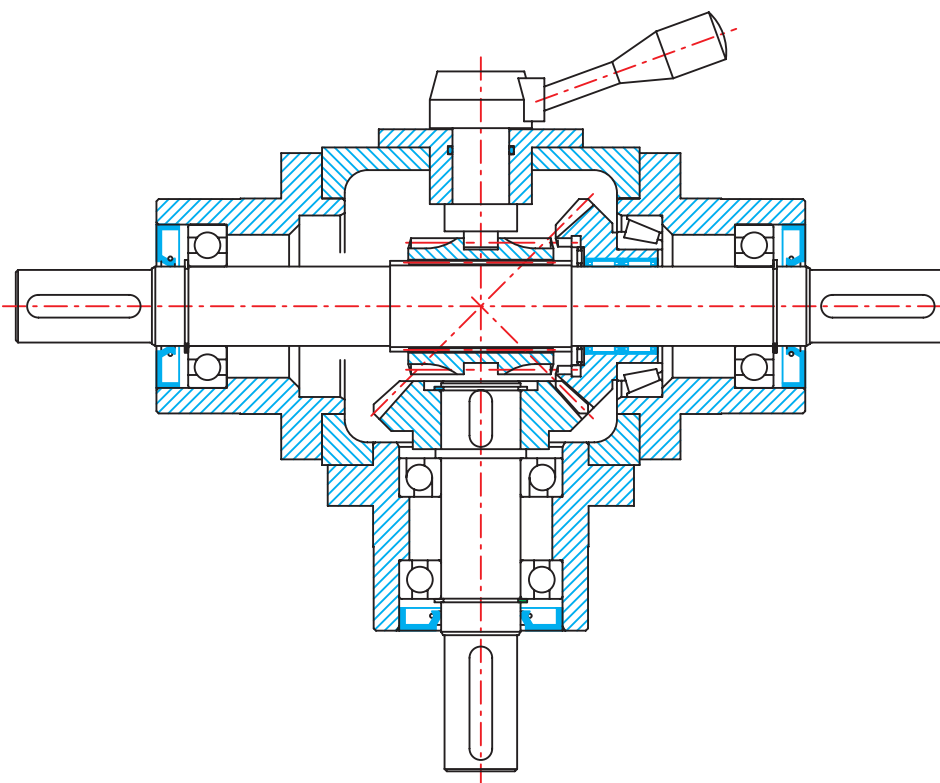

## INVERTITORI COASSIALI

TIPO IC

 Sono costituiti da una terna di ingranaggi conici con rapporto di trasmissione 1/1. Invertono il senso di rotazione dell'albero passante fermo restando quello dell'albero di entrata disponendo nella posizione intermedia di una funzione di "folle". A richiesta l'invertitore può essere munito di una terza sporgenza d'albero ortogonale.

La manovra si effettua manualmente agendo sulla leva di comando, a macchina ferma.

Sono costruiti nelle grandezze 24 - 32 - 38 - 42 - 55.

Le prestazioni corrispondono ai valori di coppia e potenza riportati pag. 5-6, diminuiti del 30%.

Le dimensioni d'ingombro e le posizioni di montaggio sono rispettivamente identiche a quelle della forma DR (pag. 50-51).

## CO-AXIAL REVERSING SPIRAL BEVEL GEARBOXES TYPE IC

 Co-axial spiral bevel gearboxes are available in ratio 1:1 only.

By moving the control lever from fully engaged through neutral to fully engaged in the apposite direction the co-axial shaft will change rotation.

On request co-axial reversing spiral bevel gearboxes may be supplied with a third projection shaft at 90 degrees.

Operation of the lever, which is normally carried out by hand, may only be done when the unit is stationary.

Co-axial reversing bevel gearboxes are produced in sizes BG24, BG32, BG38, BG42, BG55 only.

Selection corresponds to input kW and output torque as pages 5-6 reduced by 30%.

Dimensions and mounting positions are the same as type DR (pages 50-51).

## VARIATEURS MÉCANIQUES VARIATEURS COAXIAUX TYPE IC

 Ils se composent de trois engrenages coniques avec rapport de transmission 1/1.

Ils invertissent le sens de rotation de l'arbre traversant indépendamment de l'arbre d'entrée disposant dans la position intermédiaire d'une fonction de «point mort». Sur demande le variateur peut être doté d'une troisième saillie de l'arbre orthogonal. La manœuvre s'effectue manuellement en agissant sur le levier de commande, machine à l'arrêt.

Ils sont construits dans les tailles 24 - 32 - 38 - 42 - 55.

Les prestations correspondent aux valeurs de couple et puissance indiquées aux pages 5-6, réduites de 30 %.

Les dimensions d'encombrement et les positions de montage sont respectivement identiques à celles de la forme DR (pages 50 - 51).

## KOAXIALE WENDEGETRIEBE TYP IC

 Diese bestehen aus drei Kegelradern mit einem Übersetzungsverhältnis 1:1.

Sie invertieren die Rotationsrichtung der Durchgangswelle ohne die Rotationsrichtung der Eingangswelle zu verändern oder umgekehrt. In der Zwischenstellung verfügen sie über eine "Leerlauf"-Funktion.

- Die Schaltung erfolgt manuell durch Betätigen des Steuerhebels bei Maschinenstillstand.

- Auf Anfrage Kann das Wendegetriebe auch mit einem dritten Ausgang in 90° ausgestattet werden.

- Sie werden in den Baugrößen 24 - 32 - 38 - 42 - 55 hergestellt.

- Die Leistungen entsprechen den Werten Übersetzung und Leistung, wie auf Seite 4 - 5 dargestellt, abzüglich 30%.

- Die Maße der Grundflächen und die Montagepositionen entsprechen exakt denen der FORM DR (Seite 50-51).

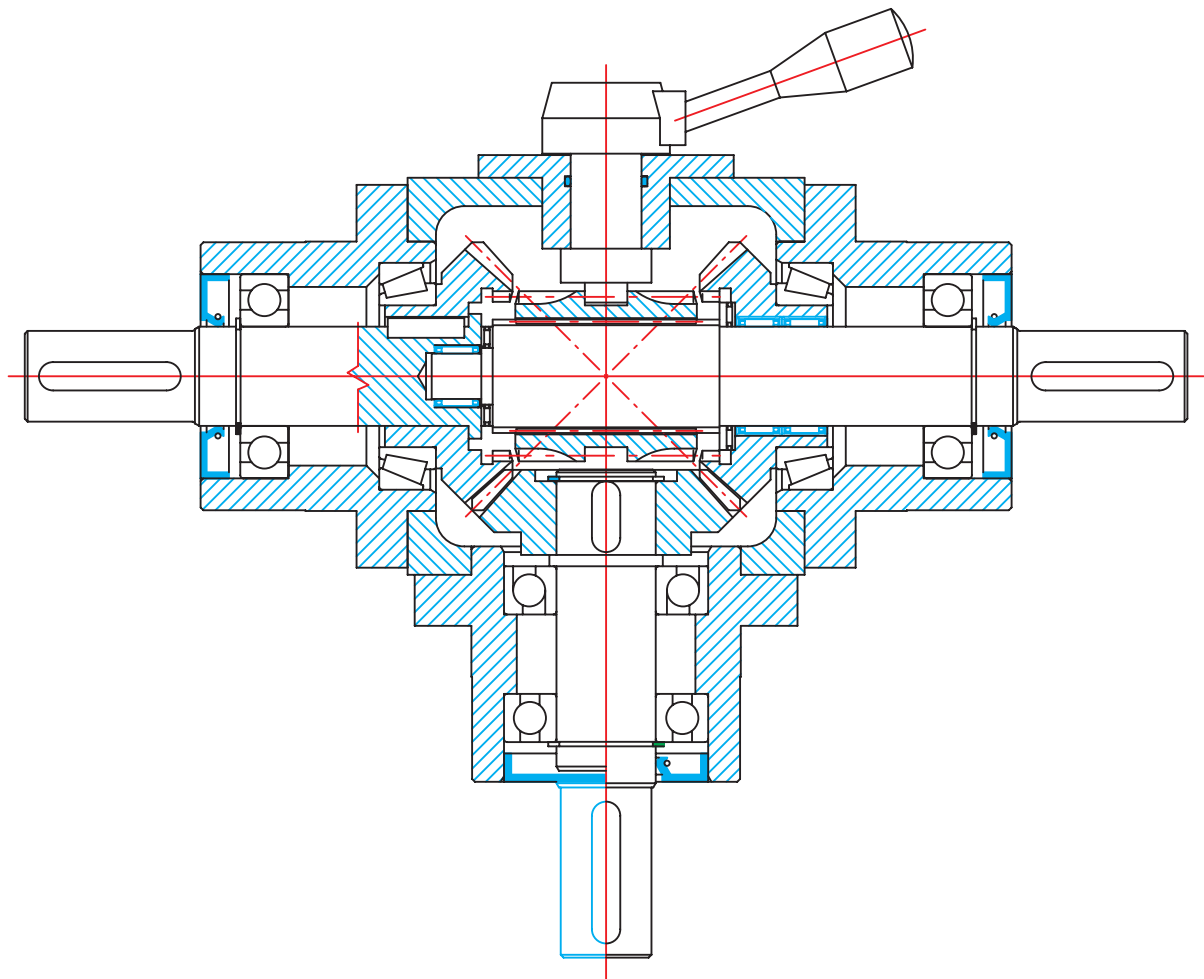

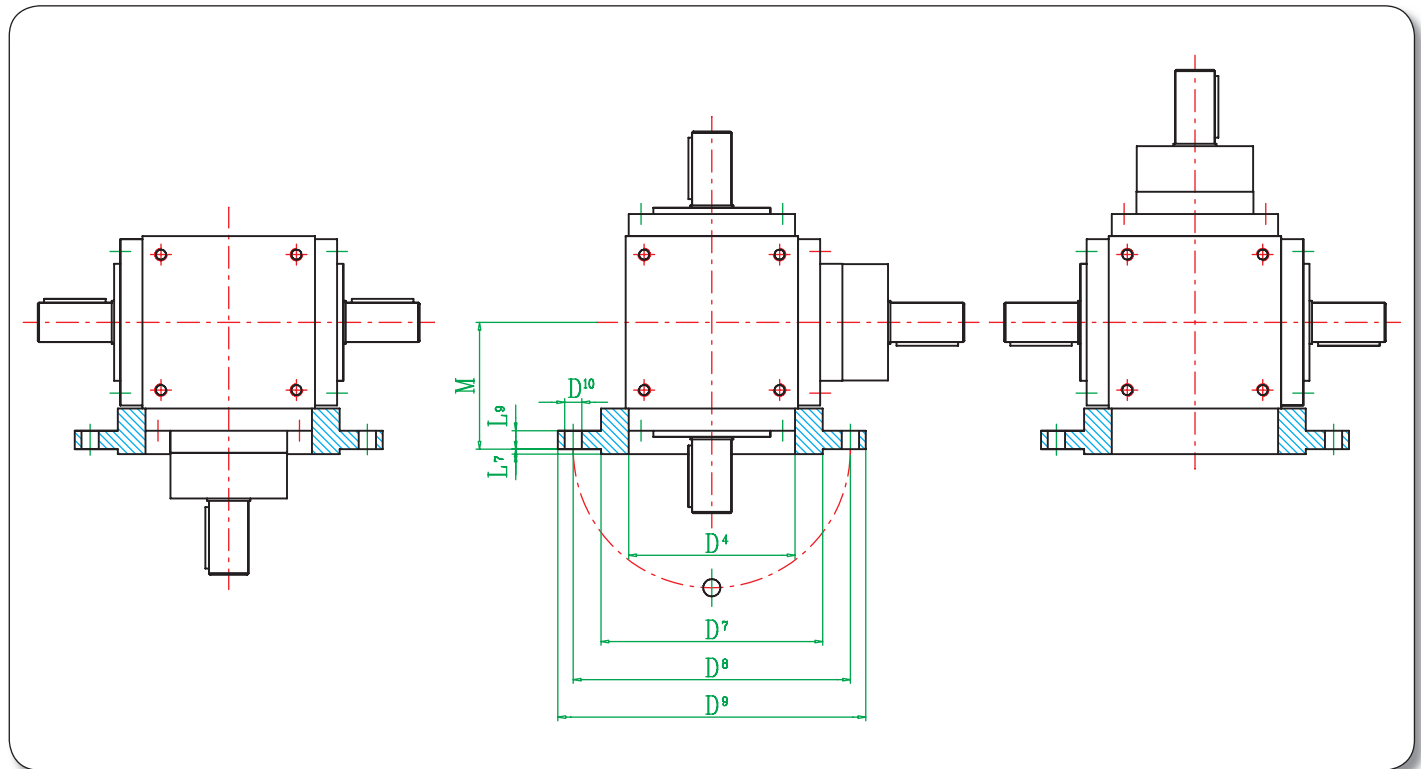

Taglia Size Taille Baugröße	$D_4$ H7	$D_7$ g6	$D_8$	$D_9$	$D_{10}$	$L_7$	$L_9$	M
BG19	86	110	130	160	9	3.5	12	70
BG24	105	130	165	200	11	3.5	13	85
BG32	135	180	215	250	14	4	15	105
BG38	165	230	265	300	14	4	15	125
BG42	190	230	265	300	14	4	15	145
BG55	230	250	300	350	18	5	18	175
BG75	300	350	400	450	18	5	25	230

Le flange sopra illustrate, vengono indicate con la sigla FC.  
Vengono altresì costruite flange denominante FP, prive del diametro di centraggio maschio " $D_7$ ".  
In questo caso si utilizza per il collegamento alla struttura il centraggio femmina " $D_4$ " e rimane inalterata la quota " $M$ ".  
Attenzione al montaggio con attacco motore a  $90^\circ$  rispetto alla flangia "FC" - "FP", infatti in questa particolare situazione potrebbe esservi interferenza.

Type FC (Male Spigot) - Type FP (Female Spigot).  
The mounting flange may be supplied with female spigot " $D_4$ " leaving dimension " $M$ " unchanged.  
Be careful when assembling a  $90^\circ$  motor fitting to flange "FC" - "FP", since in this specific situation there could be some interference between parts.

Les brides ci-dessus sont indiquées avec le sigle FC.  
Des brides nommées FP sont aussi construites sans l'accouplement mâle " $D_7$ ". Dans ce cas l'on utilise pour le raccordement à la structure l'accouplement femelle " $D_4$ " et la valeur " $M$ " reste inaltérée.  
Faire attention à tout montage comportant une attache moteur à angle droit p/r à la bride « FC » - « FP », du fait qu'en pareille situation il pourrait y avoir une interférence.

Typ FC.  
Die oben dargestellten MOTOR - FLANSCH - ADAPTER haben die Bezeichnung FC.  
Achtung beim Einbau mit Motoranschluss  $90^\circ$  zum Flansch "FC" - "FP", da in dieser besonderen Situation Interferenz bestehen könnte.

## TRATTAMENTO SUPERFICIALE ANTICORROSIVO "NIPLOY"

**CARATTERISTICHE:**  
 Il NIPLOY PROCESS è un sistema di nichelatura esclusivamente chimica ad alto tenore di fosforo che permette di ottenere sulle superfici trattate un deposito uniforme, non poroso e altamente resistente alla corrosione e all'usura. La grande uniformità di spessore del trattamento determina:

- Protezione completa zone interne (cave, fori, ecc.).
- Assoluto rispetto della rugosità di base.
- Nessuna necessità di lavorazioni meccaniche finali (rettifica).

I depositi realizzati con Niploy Process manifestano una buona aderenza al substrato; qualora si verificano danni meccanici del riporto essi non hanno tendenza a "sfolgiare" come avviene con i depositi galvanici quali il cromo. Nel caso di macroporosità del materiale di base, il deposito non consente la propagazione di eventuali fenomeni di corrosione.

**RESISTENZA:**  
 Il deposito che si origina dal trattamento Niploy Process garantisce, grazie alla struttura del riporto e alla presenza del fosforo, una elevata resistenza alla corrosione, rendendolo impiegabile in settori di applicazione quali quello farmaceutico e alimentare, in sostituzione dell'acciaio inox. Nella tabella sottostante possiamo notare una comparazione con il riporto di cromo, in una prova di 120' di durata in nebbia salina.

## "NIPLOY" ANTICORROSIVE SURFACE TREATMENT

**SPECIFICATIONS:**  
 The NIPLOY PROCESS is a purely chemical nickel-plating process with a high phosphorous content. It can provide treated surfaces with a uniform coating which is not porous and highly resistant to corrosion and wear. The uniform thickness offered by this treatment ensures:

- A total protection of inner areas (hollows, holes, etc.)
- A complete respect of the basic roughness
- No need of final mechanical machining (grinding)

The coating realized by the Niploy Process show a good adhesion to the substrate; in case of mechanical damages to the carry, this coating will not tend to "flake", contrary to what happens with galvanic coating, such as chrome. If the basic material has a high macro-porosity, coating prevents corrosion spreading, if any.

**RESISTANCE:**  
 The deposit which arises from the Niploy Process treatment ensures, thanks to the structure of the carry and the presence of phosphorus, a high resistance to corrosion, making it usable in application areas as pharmaceuticals and food, instead of stainless steel. The table below shows a comparison with chrome carry during a 120-hour salt spray test.

## TRAITEMENT SUPERFICIEL ANTICORROSIF "NIPLOY"

**CARACTÉRISTIQUES:**  
 Il NIPLOYPROCESS est un système de nickelage exclusivement chimique à haut teneur de phosphore qui permet d'obtenir sur les surfaces traitées un revêtement uniforme, non poreux et hautement résistant à la corrosion et à l'usage. La grande uniformité d'épaisseur du traitement détermine:

- Protection complète des zones internes (ouvertures, trous, etc.)
- Respect absolu de la rugosité de base
- Aucune nécessité de traitements mécaniques finals (rectification)

Les revêtements réalisés avec NiployProcess manifestent une bonne adhérence à la sous-couche; en présence de défauts mécaniques du revêtement ils n'ont pas la tendance à « s'exfolier » comme il se vérifie dans les revêtements galvaniques, tels que le chrome. Lors de macroporosité du matériel de base, le revêtement ne permet pas la propagation de phénomènes de corrosion éventuels.

**RESISTANCE:**  
 Le revêtement qui s'origine du traitement Niploy Process garantit, grâce à la structure du revêtement et à la présence de phosphore, une résistance élevée à la corrosion en le rendant employable dans des secteurs d'application comme celui pharmaceutique et alimentaire, en remplaçant l'acier inox. Dans le tableau ci-dessous il est possible de remarquer une comparaison avec le revêtement de chrome, dans un essai de 120' de durée au brouillard salin.

## "NIPLOY" ROSTSCHUTZ-OBERFLÄCHENBEHANDLUNG

**EIGENSCHAFTEN:**  
 Der NIPLOY PROCESS ist ein ausschließlich chemisches Vernickelungssystem mit hohem Phosphorgehalt, das auf behandelten Oberflächen den Erhalt einer gleichmäßigen, nicht porösen und hoch korrosions- und verschleißfesten Ablagerung ermöglicht. Die besondere Gleichmäßigkeit der Behandlungsschicht gewährleistet:

- vollkommenen Schutz der Innenbereiche (Hohlräume, Bohrungen etc.);
- absolute Einhaltung der Basisrauigkeit;
- keinerlei Erfordernis mechanischer Endbearbeitungen (Schleifen).

Die im Rahmen des Niploy Process verwirklichten Ablagerungen weisen eine gute Haftung auf ihrem Trägermaterial auf. Sollte es zu mechanischen Beschädigungen der Beschichtung kommen, neigen diese nicht zum "Abblättern" wie es sonst bei galvanischen Ablagerungen wie dem Chrom der Fall ist. Bei Makroporen des Basismaterials erlaubt die Ablagerung keine Propagation von eventuell auftretendem Rost.

**FESTIGKEIT:**  
 Die Ablagerung, die aus der Behandlung mit einem Niploy Process rührt, gewährleistet dank der Struktur der Beschichtung und dem vorhandenen Phosphor eine erhöhte Korrosionsfestigkeit und führt dazu, dass sie in bestimmten Anwendungsbereichen, wie dem Pharma- und Lebensmittelsektor, anstelle von Stahl verwendet werden kann. Nachstehende Tabelle ermöglicht einen Vergleich mit einer Chrombeschichtung in einem 120' Stunden-Salznebeltest.

	Spessore (micron) / Thickness (micron) / Épaisseur (micron) / Stärke (mikron)			
	10	25	50	75
Cromo duro (nr. pori) <i>Hard chrome (no. of pores)</i> Chrome dur (nr. pores) <i>Hartchrom (Porenanzahl)</i>	numerosi <i>many</i> nombreux <i>zahlreiche</i>	250	16	8
Niploy Process (nr. pori) <i>Niploy process (no. of pores)</i> Niployprocess (nr. pores) <i>Niploy Process (Porenanzahl)</i>	30	6	1	0



 La sua resistenza all'usura da strisciamento è pari a quella del cromo duro. Il trattamento Niploy Process resiste inoltre a sbalzi termici elevati. Da +200 °C a -192 °C senza presentare fessurazioni. Opportuni trattamenti termici ad elevate temperature (280 °C, 350 °C) consentono di indurire il riporto da valori base di 500 HV fino a valori vicini a quelli del Cromo (1000 - 1050 HV).

#### SETTORI DI APPLICAZIONE:

L'applicazione del Niploy process può essere consigliata per ottenere resistenza all'usura grazie all'aumento della durezza superficiale. Per l'utilizzatore questo si traduce in notevoli vantaggi economici, quali: aumento della vita dei pezzi, guadagno in peso sostituendo una lega più pesante con una leggera nichelata, diminuzione dei costi grazie all'utilizzo di un materiale corrente nichelato, al posto di un materiale più costoso (acciaio INOX).

Principali settori industriali interessati al trattamento NIPLOY PROCESS:

- ALIMENTARE/FARMACEUTICO
- AUTOMOBILISTICO / MOTOCICLISTICO ELETTRONICA/ TELECOMUNICAZIONI
- PETROLCHIMICO
- TESSILE
- OLEODINAMICO E PNEUMATICO
- MECCANICO/MECCANICA DI PRECISIONE
- AERONAUTICO/AEROSPAZIALE/ NAVALE

 Its resistance to sliding wear is equal to that of hard chrome. The Niploy Process treatment also resists to high sudden changes in temperature: from +200° C to -192° C without showing any cracks. A special heat treatment at high temperatures (280° C, 350° C) allows carry hardening from basic values of 500 HV up to values close to those of Chrome (1000 – 1050 HV).

#### APPLICATION AREAS:

The Niploy process can be recommended to achieve a good resistance to wear thanks to the increase of surface hardness. It offers high economic advantages to the user, such as part prolonged lifetime, weight reduction by replacing a heavier alloy with a lighter nickel-plated one, as well as cost reduction thanks to the use of a consumable nickel-plated material instead of a more expensive one (STAINLESS steel).

Main industrial fields of application of the NIPLOY PROCESS treatment:

- FOOD/PHARMACEUTICALS
- AUTOMOTIVE/MOTORCYCLE ELECTRONICS/ TELECOMMUNICATIONS
- PETROCHEMICAL
- TEXTILES
- HYDRAULICS AND PNEUMATICS
- MECHANICS / PRECISIONE MECHANICS
- AERONAUTICAL/AEROSPACE/ SHIPBUILDING

 Sa résistance à l'usure est identique à celle du chrome dur. Le traitement Niployprocess résiste également aux sautes élevées de température. De +200 °C à -192 °C sans présenter des ouvertures. Des traitements thermiques opportuns à des températures élevées (280 °C, 350 °C) permettent de durcir le revêtement des valeurs de base de 500 CV jusqu'à des valeurs proches à celles du Chrome (1 000 – 1 050 CV).

#### SECTEURS D'APPLICATION:

L'application du Niploy process peut être conseillée pour obtenir la résistance à l'usure grâce à l'augmentation de la dureté superficielle. Pour l'utilisateur cela se traduit en avantages remarquables au niveau économique, comme : prolongation de la vie des pièces, gain en poids en remplaçant un alliage plus lourd avec un alliage léger nickelé, diminution des coûts grâce à l'utilisation d'un matériel nickelé, au lieu d'un matériel plus coûteux (acier INOX).

Les secteurs industriels majeurs intéressés par le traitement NIPLOYPROCESS :

- ALIMENTAIRE/PHARMACEUTIQUE
- AUTOMOBILISTIQUE/ MOTO ÉLECTRONIQUE/ COMMUNICATIONS
- PÉTROLOCHIMIQUE
- TEXTILE
- OLÉODYNAMIQUE ET PNEUMATIQUE
- MÉCANIQUE/MÉCANIQUE DE PRÉCISION
- AÉRONAUTIQUE / AÉROSPATIAL/ NAVAL

 Die Verschleißfestigkeit beim Anschleifen entspricht der des Hartchroms. Die Niploy Process-Behandlung hält sehr hohen Temperaturen (280 °C, 350 °C) stand und erlaubt dadurch eine Härtung der Beschichtung von Grundwerten von 500 HV bis zu Werten (110 – 1050 HV), die nahe an die des Hartchroms reichen.

#### ANWENDUNGSBEREICHE:

Die Anwendung des Niploy Process ist für das Erzielen einer Verschleißfestigkeit dank einer Erhöhung der Oberflächenhärte empfehlenswert. Für den Benutzer drückt sich dies in erheblichen wirtschaftlichen Vorteilen aus, wie: längere Standzeit der Teile, geringeres Gewicht durch den Ersatz einer schwereren Legierung durch eine leichtere, vernickelte Legierung, Kostenreduzierung dank des Einsatzes eines üblichen vernickelten Materials anstelle eines teureren Materials (Edelstahl).

Industrielle Hauptsektoren, in denen der NIPLOY PROCESS verwendet wird:

- LEBENSMITTEL / PHARMAZEUTIK
- KRAFTFAHRZEUG / MOTORRÄDER
- ELEKTRONIK / TELEKOMMUNIKATION
- PETROLCHEMIE
- TEXTILIEN
- ÖLDYNAMIK UND PNEUMATIK
- MECHANIK / PRÄZISIONSMECHANIK
- AERONAUTIK / LUFTFAHRT / SCHIFFFAHRT



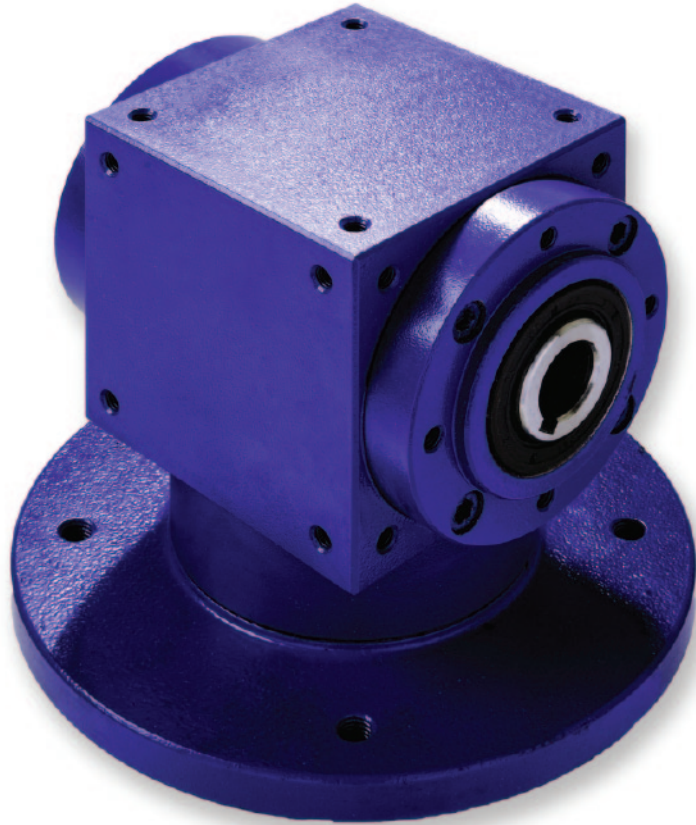
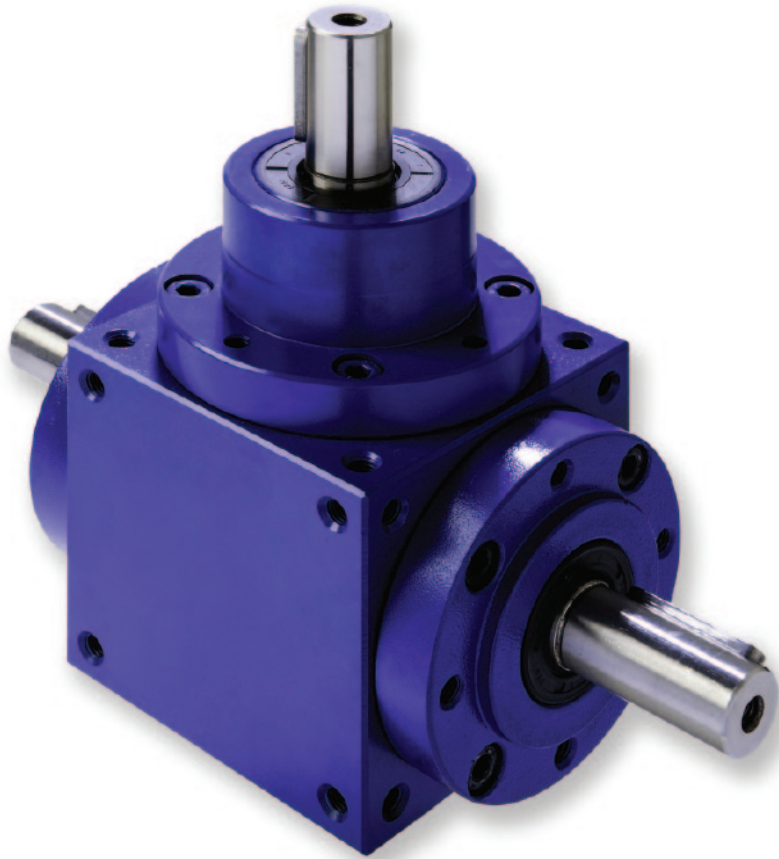







- Il presente catalogo annulla e sostituisce i precedenti.  
- È vietata la riproduzione, anche parziale, senza specifica autorizzazione scritta della P.C.M. Srl Trasmissioni Meccaniche.  
- La P.C.M. Srl Trasmissioni Meccaniche si riserva la facoltà di variare i dati del presente catalogo senza preavviso.  
- La P.C.M. Srl Trasmissioni Meccaniche non riconosce alcuna responsabilità per errori od omissioni presenti nel catalogo.



- This catalogue supersedes any previous issue.  
- It is forbidden to copy this document, in whole or in part, unless previously authorised by P.C.M. Srl Trasmissioni Meccaniche in writing.  
- P.C.M. Srl Trasmissioni Meccaniche reserves the right to change the data on this catalogue without prior notice.  
- P.C.M. Srl Trasmissioni Meccaniche shall not be held liable for any mistakes or omissions possibly present in this catalogue.



- Ce catalogue annule et remplace tous catalogues précédents.  
- Toute reproduction, même partielle, est interdite sans aucune autorisation écrite délivrée par P.C.M. Srl Trasmissioni Meccaniche.  
- P.C.M. Srl Trasmissioni Meccaniche se réserve la faculté de changer les données contenues dans ce catalogue sans préavis.  
- P.C.M. Srl Trasmissioni Meccaniche ne reconnaît aucune responsabilité quant aux erreurs ou omissions contenues dans ce catalogue.



- Der vorliegende Katalog annulliert und ersetzt die vorhergehenden.  
- Die Reproduktion ohne besondere schriftliche Genehmigung vonseiten der P.C.M. Srl Trasmissioni Meccaniche ist – selbst teilweise – verboten.  
- P.C.M. Srl Trasmissioni Meccaniche behält sich vor, die Daten des vorliegenden Katalogs ohne Vorbescheid abzuändern.  
- P.C.M. Srl Trasmissioni Meccaniche haftet nicht für Fehler oder mangelnde Angaben im vorliegenden Katalog.



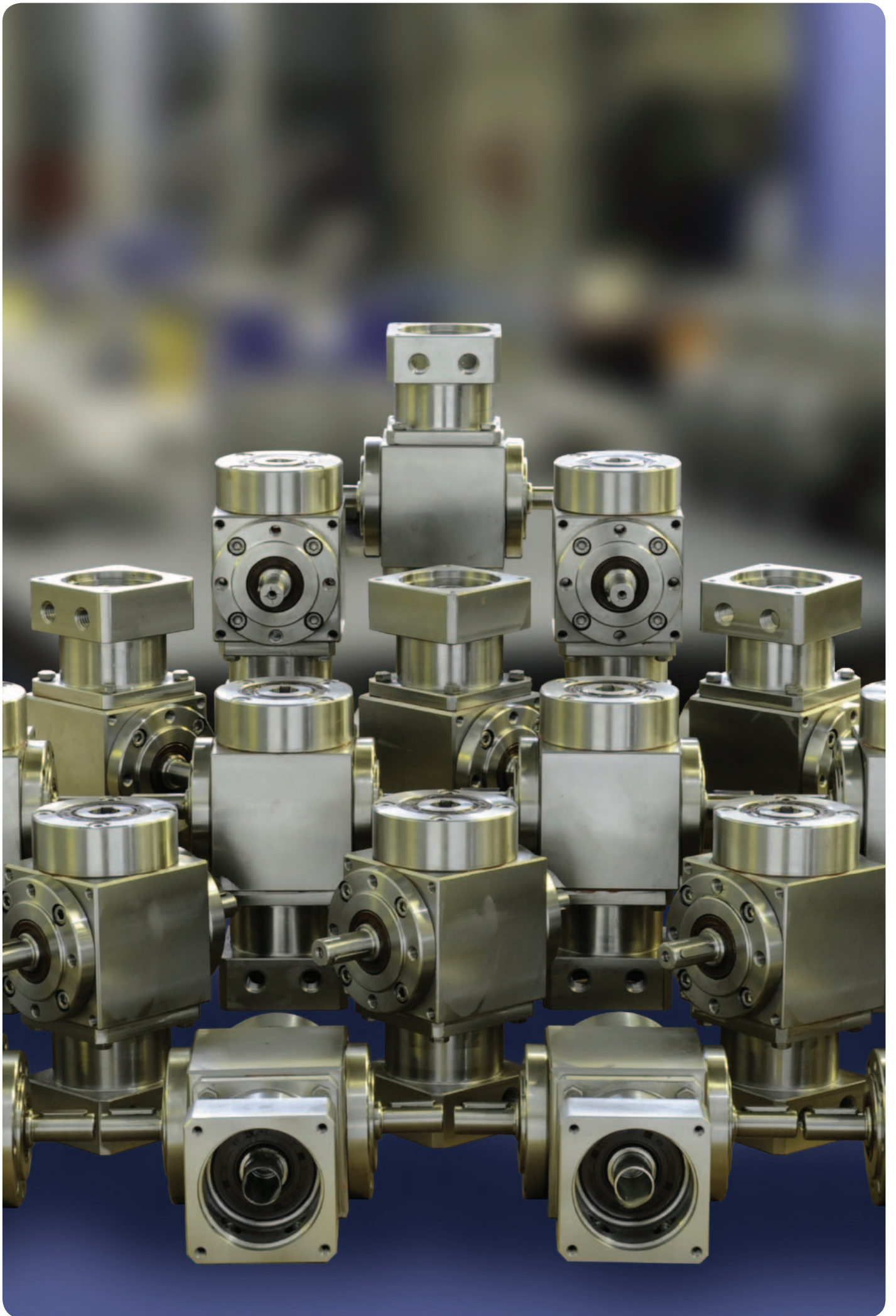



**P.C.M. s.r.l.**  
**TRASMISSIONI MECCANICHE**

Via Emilia, 11 - Zona Industriale  
35043 Monselice - Padova (Italy)  
Tel. +39 0429 75377  
Fax +39 0429 780372  
info@pcmiduttori.it

**[www.pcmiduttori.it](http://www.pcmiduttori.it)**